

**PROPER USE GUIDELINES**

Cumulative Trauma Disorders can result from the prolonged use of manually powered hand tools. Hand tools are intended for occasional use and low volume applications. A wide selection of powered application equipment for extended-use, production operations is available.

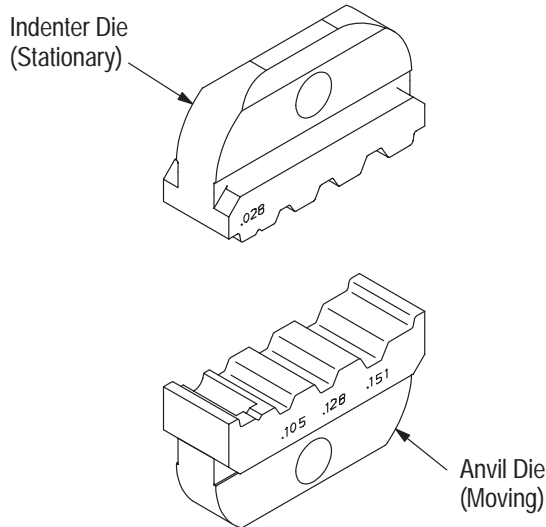

Figure 1

**1. INTRODUCTION**

This instruction sheet covers the use and maintenance of Hex Crimping Die Assembly 1583696-1, which is used in PRO-CRIMPER\* II Hand Tool Frame Assembly 354940-1. The die assembly crimps various configurations of RF Coaxial Connectors onto coaxial cable. In this use, the die assembly provides for the crimping of the center contact.

Tyco Electronics Catalog 1307191 provides a guide for cable-to-connector selection. For cable sizes and connectors not referenced in the catalog, contact Tyco Electronics Product Engineering for connector recommendations.

Reasons for reissue are provided in Section 7, REVISION SUMMARY.

**NOTE**

*Dimensions in this instruction sheet are in metric units [with U.S. customary units in brackets]. Figures are for reference only and are not drawn to scale.*

**2. DESCRIPTION** (Figure 1)

Each die assembly consists of an indenter die and an anvil die. When closed, the dies form four crimping chambers, one of which crimps the center contact while the remaining three crimp the ferrule of the connector onto various sizes of coaxial cable. Each die is held in the tool by a single screw.

**3. DIE INSTALLATION**

1. Close the tool handles until the ratchet releases, then allow the handles to open fully.
2. Insert the dies into the tool jaws as shown in Figure 2, and align the retaining holes in each die with the associated holes in the tool frame.

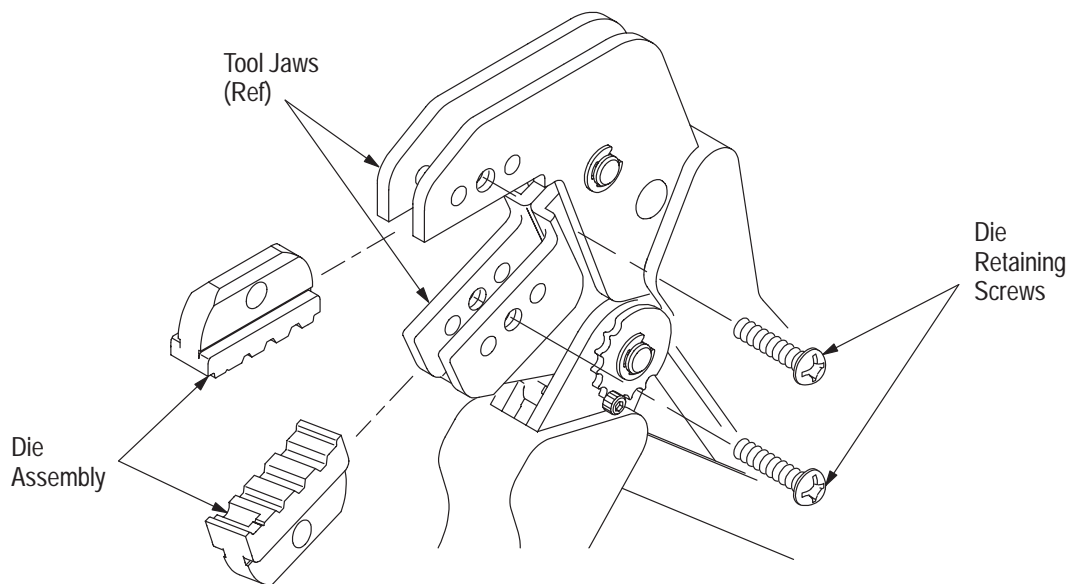

Figure 2

3. Thread, but do not tighten, the die retaining screws into the holes.
4. Carefully close the tool handles, making sure that the dies align properly.
5. Tighten the die retaining screws with the appropriate hex wrench.

#### 4. CRIMPING PROCEDURE

**NOTE**

*This tool will not provide a crimp conforming to military requirements, nor can it be used on mil-type connectors.*

Before proceeding with crimping, determine the proper tool and setting to provide the center conductor crimp. Follow the manufacturer's recommended procedure.

1. Make sure that the connector ferrule has been placed onto the cable, and that the cable braided shield is flared away from the cable.
2. Crimp the center contact by sliding it onto the stripped center conductor of the coaxial cable until it is butted against the dielectric, placing the center contact in the smallest crimping chamber of the anvil die, and closing the tool handles until the ratchet releases.
3. Insert the crimped center contact into the connector body until the cable dielectric butts against the dielectric inside of the connector body or until the center contact is securely positioned within the connector. Make sure that the braided shield is over the support sleeve of the connector body, and that no strands from the shield enter the connector body.
4. Slide the ferrule over the braided shield and onto the connector until the ferrule butts against the shoulder on the connector body.
5. Place the ferrule on the appropriate crimping chamber of the anvil die so that the shoulder on the connector body is close to the edge of the die.

**NOTE**

*To determine the appropriate crimping chamber, observe the markings above the crimping chambers, and refer to the instructions packaged with the connector.*

6. While holding the assembly together, begin to close the tool handles. Keep holding the assembly until the dies have closed enough to clamp the assembly in place.
7. Carefully close the tool handles until the ratchet releases.

8. Allow the tool handles to open fully and remove the crimped connector from the dies.

**CAUTION**

*Damaged product must not be used. If damaged product is evident, it must be cut from the wire and replaced with a new one. Contacts or connectors must not be reterminated.*

#### 5. MAINTENANCE AND INSPECTION

##### 5.1. Daily Maintenance

1. Remove dust, moisture, and other contaminants with a clean, soft brush, or a clean, soft, lint-free cloth. Do NOT use any objects that could damage the dies or tool.
2. Make sure that the proper die retaining screws are properly secured.
3. When the dies are not in use, store them in a clean, dry area. When the tool is not in use, store it with the handles closed to prevent objects from becoming lodged within the jaws.

##### 5.2. Visual Inspection

1. Remove all lubrication and accumulated film from the dies by immersing the dies in a suitable commercial degreaser.
2. Make certain that all die retaining screws and die components are properly secured.
3. Inspect the crimping surfaces for flattened, chipped, worn, or cracked areas. If damage is evident, the dies must be replaced. Refer to Section 6, REPLACEMENT.

##### 5.3. Measuring Die Opening

The die assembly will perform correctly as long as: (1) the product specified is correct for the application, (2) the specific die assembly is used, (3) the die assembly has been measured to ensure that the openings are correct, and (4) the die assembly bottoms.

Figure 3 provides information on die opening sizes.

For specific applications where wire stiffness, material, or insulation may give different than standard performance, it may be necessary to measure the crimped ferrule, rather than to verify the size of the die opening. This inspection requires the use of a cone or modified micrometer (Crimp Height Comparator RS-1019-5LP), which is available from:

Shearer Industrial Supply Co.  
717-767-7575

or VALCO  
610-691-3205

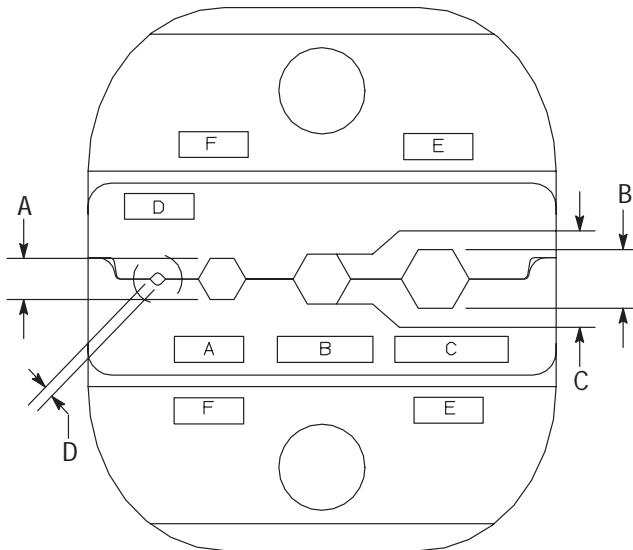

DIE ASSEMBLY	DIE OPENING			
	$\pm 0.10$ [ $\pm .004$ ]			$\pm 0.05$ [ $\pm .002$ ]
	A	B	C	D
1583696-1	2.67 [.105]	3.84 [.151]	3.25 [.128]	0.71 [.028]

Figure 3

#### 5.4. Ratchet Adjustment (Figure 4)

The tool frame assembly ratchet mechanism features an adjustment wheel with numbered settings. If the crimp height is not acceptable, adjust the ratchet as follows:

1. Remove the lock screw from the ratchet adjustment wheel.
2. With a screwdriver, adjust the ratchet wheel from the opposite side of the tool.
3. Observe the ratchet adjustment wheel. If a tighter crimp is required, rotate the adjustment wheel COUNTERCLOCKWISE to a higher-numbered setting. If a looser crimp is required, rotate the adjustment wheel CLOCKWISE to a lower-numbered setting.

4. Replace the lock screw.

5. Make a sample crimp and measure the crimp height. If the crimp height is acceptable, secure the lock screw. If the dimension is unacceptable, remove lock screw and continue to adjust the ratchet, and again measure a sample crimp.

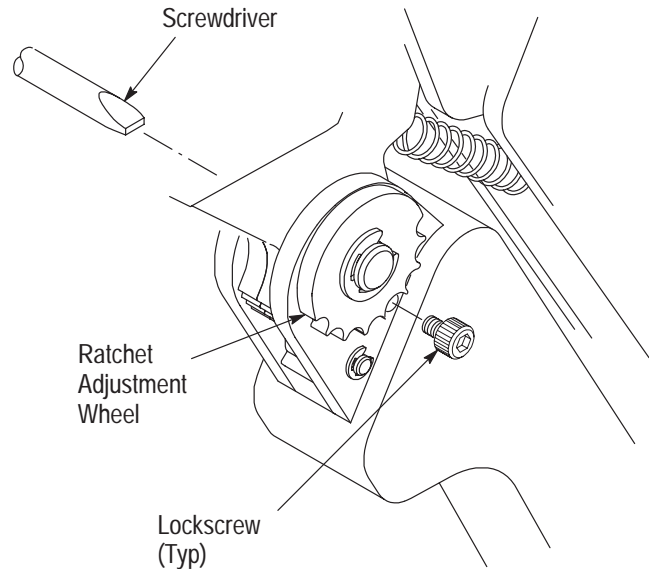

Figure 4

#### 6. REPLACEMENT

Order replacement parts through your Tyco Electronics Representative, or call 1-800-526-5142, or send a facsimile of your purchase order to 1-717-986-7605, or write to:

CUSTOMER SERVICE (38-35)  
TYCO ELECTRONICS CORPORATION  
P.O. BOX 3608  
HARRISBURG, PA 17105-3608

#### 7. REVISION SUMMARY

Initial release of document per: EC 0990-1083-03.