

PROPER USE GUIDELINES

Cumulative Trauma Disorders can result from the prolonged use of manually powered hand tools. Hand tools are intended for occasional use and low volume applications. A wide selection of powered application equipment for extended-use, production operations is available.

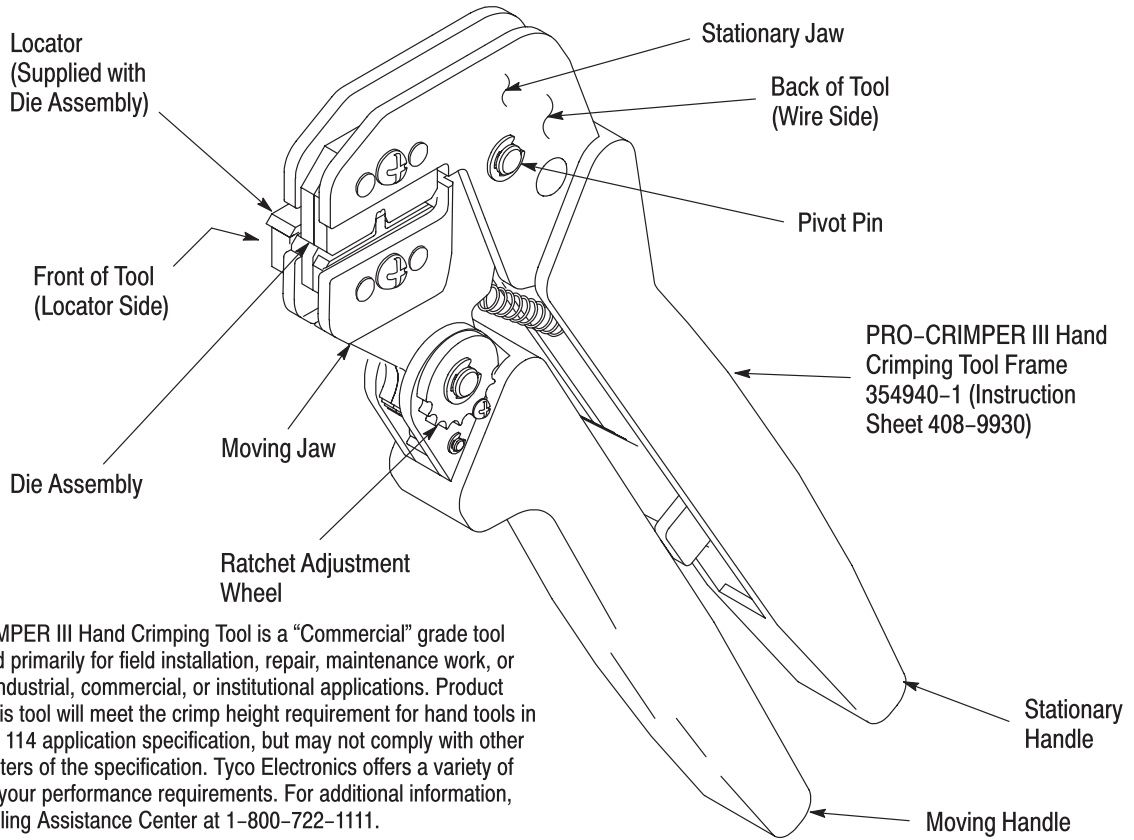

The PRO-CRIMPER III Hand Crimping Tool is a “Commercial” grade tool and is designed primarily for field installation, repair, maintenance work, or prototyping in industrial, commercial, or institutional applications. Product crimped with this tool will meet the crimp height requirement for hand tools in the appropriate 114 application specification, but may not comply with other feature parameters of the specification. Tyco Electronics offers a variety of tools to satisfy your performance requirements. For additional information, contact the Tooling Assistance Center at 1-800-722-1111.

PRO-CRIMPER III Hand Tool	Die Assembly Part Number	Locator Part Number †	Contact Family ‡	Wire		
				Size (AWG)	Insul Dia (mm {In.})	Strip Length (mm {In.})
58517-1	58517-2	189590-1	CST 100	26-22	0.89-1.65	2.54-2.92
58517-3	58517-4	1424907	CST 100 II		[.035-.065]	[.100-.125]

† Supplied with the die assembly. Also available separately.

‡ Contact the PRODUCT INFORMATION CENTER for specific contact part numbers.

Figure 1

1. INTRODUCTION

PRO-CRIMPER III Hand Crimping Tool Assembly 58517-1 consists of Die Assembly 58517-2 and PRO-CRIMPER III Hand Tool Frame 354940-1. See Figure 1.

PRO-CRIMPER III Hand Crimping Tool Assembly 58517-3 consists of Die Assembly 58517-4 and PRO-CRIMPER III Hand Tool Frame 354940-1. See Figure 1.

The die assembly consists of crimping dies and a locator assembly.

Read these instructions thoroughly before crimping any contacts.

NOTE

Dimensions on this sheet are in millimeters [with inch equivalents provided in brackets]. Figures and illustrations are for identification only and are not drawn to scale.

Reasons for reissue are provided in Section 11, REVISION SUMMARY.

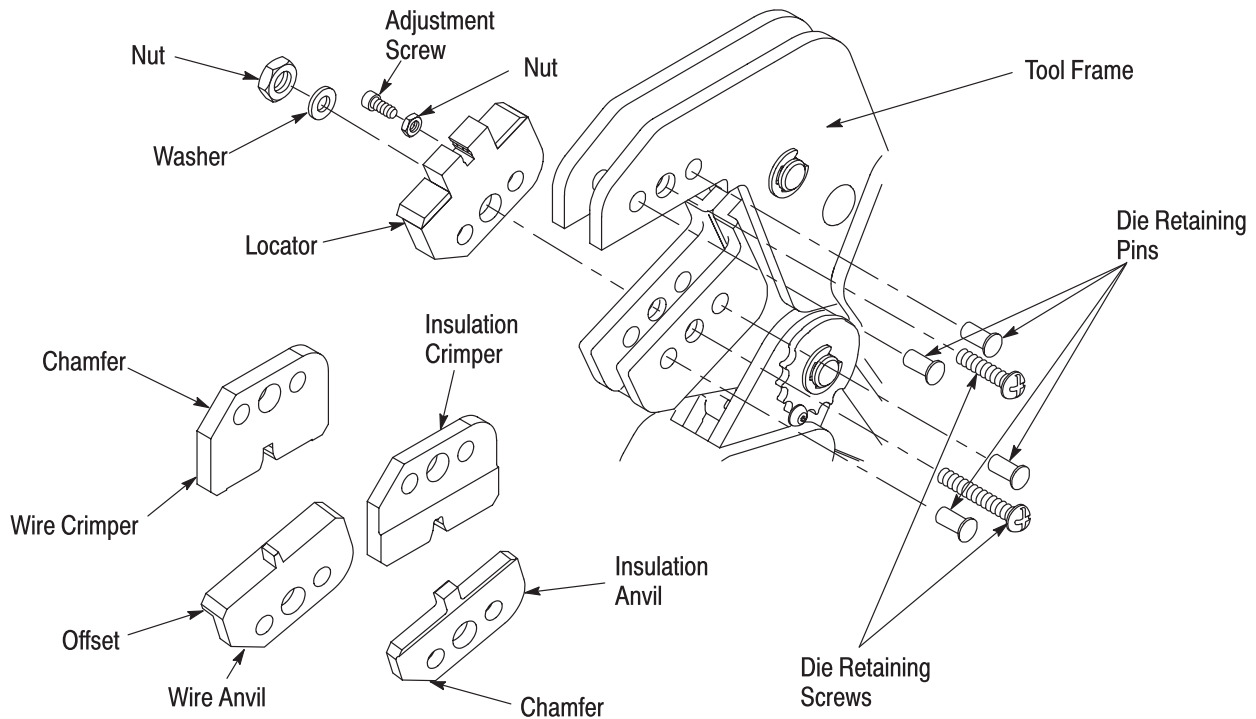

Figure 2

2. DESCRIPTION (Figures 1 and 2)

The tool features a tool frame with a stationary jaw and handle, a moving jaw, a moving handle, and an adjustable ratchet that ensures full contact crimping. The tool frame holds a die assembly with one crimping section.

The die assembly features a wire anvil, an insulation anvil, a wire crimper, and an insulation crimper.

Attached to the outside of the frame is a locator, which holds and helps to position the contact.

Die retaining pins and die retaining screws are used to position and secure the dies in the tool frame. A washer and nut is used on the lower die retaining screw to hold the locator in place.

3. INSTALLATION AND REMOVAL OF DIE SET AND LOCATOR ASSEMBLY (Figure 2)

1. Open the tool handles and remove the two die retaining screws from the tool jaws.
2. Place the wire anvil and insulation anvil in the moving jaw so that their chamfered sides and their marked surfaces face outward, when mounted in the moving jaw of the tool frame.
3. Insert the two die retaining pins.
4. Insert the long die retaining screw through the jaw and through both anvil dies, and tighten the

screw just enough to hold the dies in place. Do *not* tighten the screw completely at this time.

5. Place the wire crimper and insulation crimper in the stationary jaw so that their chamfered sides and their marked surfaces face outward, when mounted in the stationary jaw of the tool frame.

6. Insert the two die retaining pins.

7. Insert the short die retaining screw through the jaw and through both crimper dies, and tighten the screw just enough to hold the dies in place. Do *not* tighten the screw completely at this time.

8. Carefully close the tool handles, making sure that the anvils and crimpers align properly. Continue closing the tool handles until the ratchet in the tool frame has engaged sufficiently to hold the anvils and crimpers in place, then tighten both die retaining screws.

9. Place the locator over the end of the long screw, and position the locator against the side of the tool jaw.

10. Place the washer and nut onto the end of the long screw. Align the locator slot with the crimping section and carefully tighten the nut.

11. To disassemble, close the tool handles until the ratchet releases, remove the nut, the washer, the locator, the two die retaining screws, and the four die retaining pins, and slide the anvils and crimpers out of the tool jaws.

4. CRIMPING PROCEDURE

NOTE *This tool is provided with a crimp adjustment feature. Initially, the crimp height should be verified as specified in Figure 4. Refer to Section 6, CRIMP HEIGHT INSPECTION, and Section 7, CRIMP HEIGHT ADJUSTMENT, to verify crimp height before using the tool to crimp desired contacts and wire sizes.*

Refer to the table in Figure 1 and select wire of the specified size and insulation diameter. Strip the wire to the length indicated in Figure 1, taking care not to nick or cut wire strands. Select an applicable contact and identify the appropriate die assembly according to the wire size markings on the die. Refer to Figure 3 and proceed as follows:

1. Hold the tool so that the back (wire side) is facing you. Squeeze tool handles together and allow them to open fully.

2. Holding the contact by the insulation barrel, insert the contact — mating end first — into the locator slot. Position the contact so that the open “U” of the wire and insulation barrels face the top of the tool. Make sure the contact butts against the adjustment screw. Check that the contact is centered with the die assembly wire and insulation anvils. If adjustment is required, refer to Section 5, CONTACT SUPPORT ADJUSTMENT.

CAUTION *Make sure that both sides of the insulation barrel are started evenly into the crimping section. Do NOT attempt to crimp an improperly positioned contact.*

3. Hold the contact in position and squeeze the tool handles together until ratchet engages sufficiently to hold the contact in position. Do NOT deform insulation barrel or wire barrel.

NOTE *The ratchet has detents that create audible clicks as the tool handles are closed.*

4. Insert stripped wire into contact insulation and wire barrels until it is butted against the wire stop on the contact, as shown in Figure 3.

5. Holding the wire in place, squeeze tool handles together until ratchet releases. Allow tool handles to open and remove crimped contact.

6. Check the contact’s crimp height as described in Section 6, CRIMP HEIGHT INSPECTION. If necessary, adjust the crimp height as described in Section 7, CRIMP HEIGHT ADJUSTMENT.

5. CONTACT SUPPORT ADJUSTMENT (Figure 3)

1. Make a sample crimp according to Section 4, CRIMPING PROCEDURE. If the crimp is out of alignment, adjustment is required.

2. To move the contact from side-to-side, loosen the nut that holds the locator to the frame and slide the locator until the contact is properly positioned. Hold the locator in place and tighten the nut.

3. To move the contact in or out, loosen the nut on the adjustment screw and turn the screw until the contact is properly positioned. Hold the screw in place and tighten the nut.

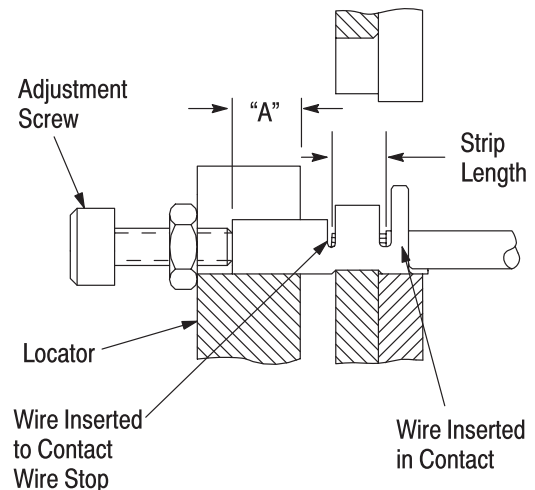
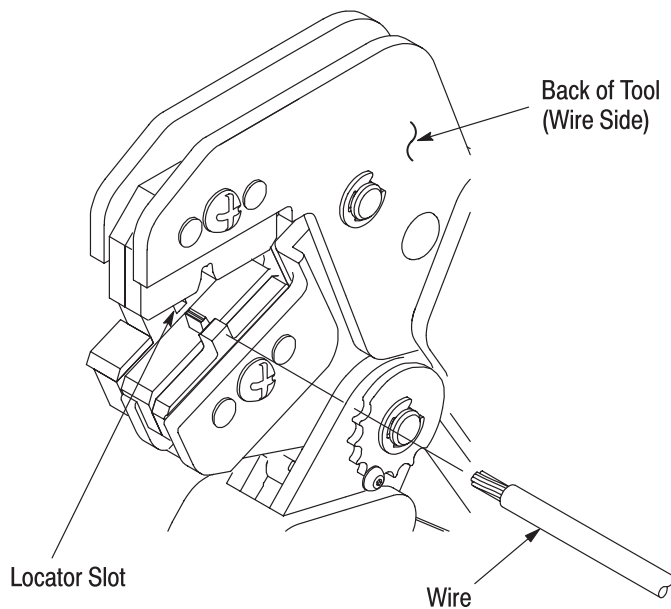

Tool No.	Dim “A”
58517-1 & 58517-2	2.641 [.104]
58517-3 & 58517-4	4.191 [.165]

Figure 3

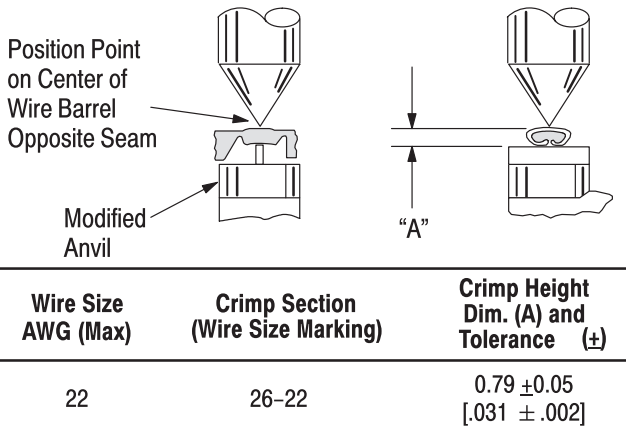

Figure 4

4. If the crimp is still out of alignment, repeat the adjustment procedure.

6. CRIMP HEIGHT INSPECTION

This inspection requires the use of a micrometer with a modified anvil.

NOTE Tyco Electronics does not manufacture or market these gages. However, TE recommends the modified micrometer (Crimp Height Comparator RS-1019-5LP).

Proceed as follows:

1. Refer to Figure 4 and select a wire (maximum size) for the crimp section.
2. Refer to Section 4, CRIMPING PROCEDURE, and crimp the contact(s) accordingly.

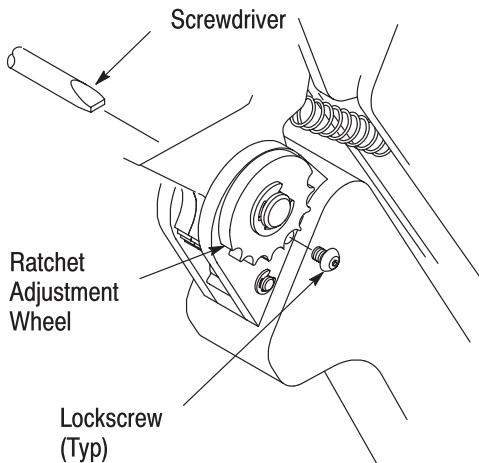

Figure 5

3. Using a crimp height comparator, measure the wire barrel crimp height as shown in Figure 4. If the crimp height conforms to that shown in the table, the tool is considered dimensionally correct. If not,

the tool must be adjusted. Refer to Section 7, CRIMP HEIGHT ADJUSTMENT.

7. CRIMP HEIGHT ADJUSTMENT (Figure 5)

1. Remove the lockscrew from the ratchet adjustment wheel.
2. With a screwdriver, adjust the ratchet wheel from the locator side of the tool.
3. Observe the ratchet adjustment wheel. If a tighter crimp is required, rotate the adjustment wheel COUNTERCLOCKWISE to a higher-numbered setting. If a looser crimp is required, rotate the adjustment wheel CLOCKWISE to a lower-numbered setting.
4. Replace the lockscrew.
5. Make a sample crimp and measure the crimp height. If the dimension is acceptable, replace and secure the lockscrew. If the dimension is unacceptable, continue to adjust the ratchet, and again measure a sample crimp.

8. MAINTENANCE

Ensure that the tool and dies are clean by wiping them with a clean, soft cloth. Remove any debris with a clean, soft brush. Do not use objects that could damage the tool. When not in use, keep handles closed to prevent objects from becoming lodged in the crimping dies, and store in a clean, dry area.

9. VISUAL INSPECTION

The crimping dies should be inspected on a regular basis to ensure that they have not become worn or damaged. Inspect the crimp section for flattened, chipped, worn, or broken areas. If damage or abnormal wear is evident, the tool must be replaced. See Section 10, REPLACEMENT.

10. REPLACEMENT

Customer-replaceable parts are shown in Figure 1. Available separately, PRO-CRIMPER III Hand Tool Repair Kit 679221-1 includes a replacement nut and a variety of pins, rings, screws, and springs. If the dies are damaged or worn excessively, they must be replaced. Order the repair kit and replaceable parts through your Tyco Electronics representative, or call 1-800-526-5142, or send a facsimile of your purchase order to 1-717-986-7605, or write to:

11. REVISION SUMMARY

Since the previous release of this sheet, the following changes were made:

- TE logo was applied; and
- PRO-CRIMPER II Hand Tool was changed to PRO-CRIMPER III Hand Tool.