

**Product:** COPALUM\* Terminals and Splices  
**Wire Size:** 8 AWG, Stranded Copper, Film-Insulated  
Copper, or Film-Insulated Aluminum  
**Product Catalog:** 82020  
**Tooling Catalog:** 124208

Figure 1

## 1. INTRODUCTION

AMP\* 626 Pneumatic Crimping Heads 662546-1 and 1320369-1 (shown in Figure 1) are designed to crimp AMP COPALUM terminals, butt splices, and parallel splices onto wire size 8 AWG. The crimping heads are used with 626 Pneumatic Tooling Assemblies 189721-2 or 189722-2 when fitted with Tool Holder Assembly 189767-1 or 356302-1.

This instruction sheet provides recommended procedures for wire preparation, crimping head installation, crimping, and maintenance and inspection. For setup and operation of the pneumatic tools, refer to Customer Manual 409-5862 packaged with the pneumatic tooling assembly. Read these instructions thoroughly before proceeding.

### NOTE

Dimensions on this sheet are in metric units [with U.S. customary units in brackets]. Figures are not drawn to scale.

Reasons for reissue of this document are provided in Section 9, REVISION SUMMARY.

## 2. DESCRIPTION

Each pneumatic crimping head is designed with integral jaws which close in an arc-like motion. To ensure proper crimping head selection, each crimping head link is stamped with a wire size range which must correspond with the wire size range stamped on the terminal or splice.

After an operator locates the terminal or splice between the crimping jaws and inserts the stripped wire, the pneumatic tool is activated to crimp the product to the wire.

### 3. HEAD INSTALLATION AND REMOVAL

**NOTE** Crimping heads are coated with a preservative to prevent rust and corrosion. Wipe this preservative from the crimping head, particularly from the crimping surfaces.

#### 3.1. Installation

**DANGER** To avoid personal injury, ALWAYS disconnect pneumatic tool from air supply before installing or removing the crimping head.

**DANGER** DO NOT operate pneumatic tool without the proper crimping head installed. After crimping head is installed, make sure that the quick pins are FULLY tightened to avoid personal injury or damage to the tool.

1. Remove quick pins from tool holder. Refer to Figure 1.
2. Insert crimping head into tool holder as shown in Figure 1.
3. After crimping head is properly aligned, insert and tighten quick pins provided with the tool holder. See Figure 1.

**NOTE** Tyco recommends using LOCTITE† 242 removable threadlock, or equivalent, to prevent the quick pins from loosening.

4. Connect pneumatic tool to an adequate air supply between 620–690 kPa [90–100 psi]. For specific information on air line requirements and air hose installation, refer to the customer manual packaged with the pneumatic tooling assembly.

#### 3.2. Removal

**DANGER** To avoid personal injury, ALWAYS disconnect pneumatic tool from air supply before removing crimping head.

Remove quick pins from crimping head; then remove crimping head from tool holder.

### 4. WIRE SELECTION AND PREPARATION

#### 4.1. Wire Selection

Select wire for the terminals and splices according to Application Specification 114-2121.

#### 4.2. Wire Preparation

If using stranded copper wire, strip the wire to dimensions shown in Figure 2. DO NOT nick wire strand or use wires with nicked or missing conductor strands.

† Trademark of Loctite Corporation

**NOTE** Do not strip film-insulated copper or film-insulated aluminum wire.

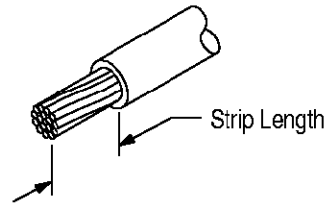

Note: Not to Scale

CRIMPING HEAD	STRANDED COPPER WIRE		
	SIZE (AWG)	CIRCULAR MIL AREA	STRIP LENGTH (mm [IN.])
662546-1 1320369-1	8	13,100–20,800	10.31–11.86 [.406–.469]

Figure 2

### 5. CRIMPING PROCEDURE

**DANGER** To avoid personal injury, ALWAYS keep fingers clear of crimping jaws when operating the tool. Never place anything within the crimping jaws except terminals and splices.

#### 5.1. Terminal Crimping Procedure

1. Open crimping jaws by squeezing rollers together simultaneously; then position the terminal in the crimping chamber on the lower jaw, as shown in Figure 3, Detail A. The terminal is properly positioned when the back of the terminal is facing the upper jaw and the wire barrel is against the locator.
2. After terminal is properly positioned, release rollers to allow crimping jaws to spring shut, holding terminal in place.
3. Insert stripped wire into terminal wire barrel until the end of the conductor butts against the locator.
4. Activate the tool to complete the crimp. Open crimping jaws by squeezing the rollers together simultaneously; then remove crimped terminal.
5. Refer to Section 6 for crimp inspection.

#### 5.2. Butt Splice Crimping Procedure

1. Open crimping jaws by squeezing rollers together simultaneously; then position the butt splice in the crimping chamber on the lower jaw, as shown in Figure 3, Detail B. The butt splice is properly positioned when the window in the splice is facing the upper jaw and the splice wire stop is sitting on the locator.

2. After splice is properly positioned, release rollers to allow crimping jaws to spring shut, holding splice in place.
3. Insert stripped wire into splice wire barrel until the end of the conductor butts against the splice wire stop.
4. Activate the tool to complete the crimp. Open crimping jaws by squeezing the rollers together simultaneously; then remove crimped splice.
5. To crimp the other half of the splice, follow the same procedure for the uncrimped half of the splice.

**NOTE** *A slight bend in the splice may result from crimping the other half of the splice as instructed in Step 1. If a bend would be objectionable, position the other half of the splice in the crimping chamber by rotating the splice 180° end-over-end; then crimp.*

6. Refer to Section 6 for crimp inspection.

### 5.3. Parallel Splice Crimping Procedure

1. Open crimping jaws by squeezing rollers together simultaneously; then position the parallel splice in the crimping chamber on the lower jaw, as shown in Figure 3, Detail C. The parallel splice is properly positioned when the end of the splice is against the locator.
2. After splice is properly positioned, release rollers to allow crimping jaws to spring shut, holding splice in place.
3. Insert stripped wires into splice until the end of the conductors butt against the locator.
4. Activate the tool to complete the crimp. Open crimping jaws by squeezing the rollers together simultaneously; then remove crimped splice.
5. Refer to Section 6 for crimp inspection.

### 6. CRIMP INSPECTION

Inspect crimped terminals and splices by checking the features described in Figure 4. Use only terminals and splices that meet the conditions shown in the "ACCEPT" column. "REJECT" terminations can be avoided through careful use of instructions in Sections 4 and 5, and by performing regular crimping head maintenance as described in Section 7.

**Detail A — Terminal**

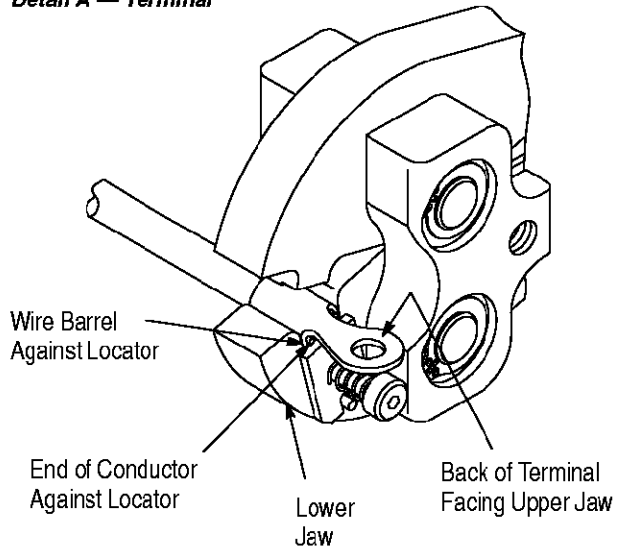

**Detail B — Butt Splice**

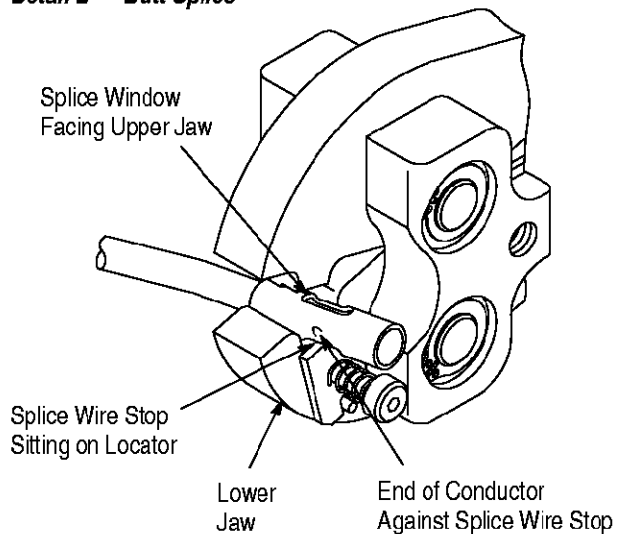

**Detail C — Parallel Splice**

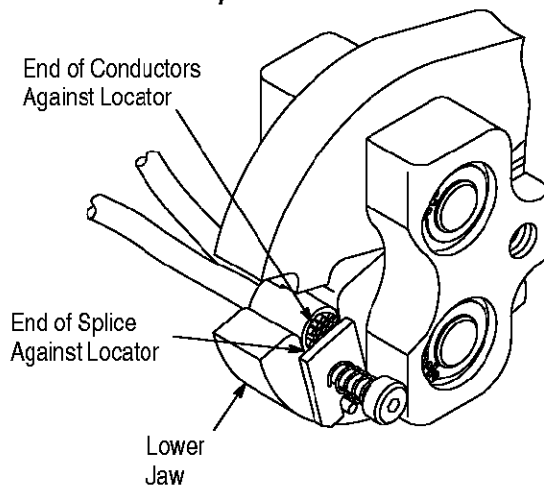

*Figure 3*

**Crimp Inspection**

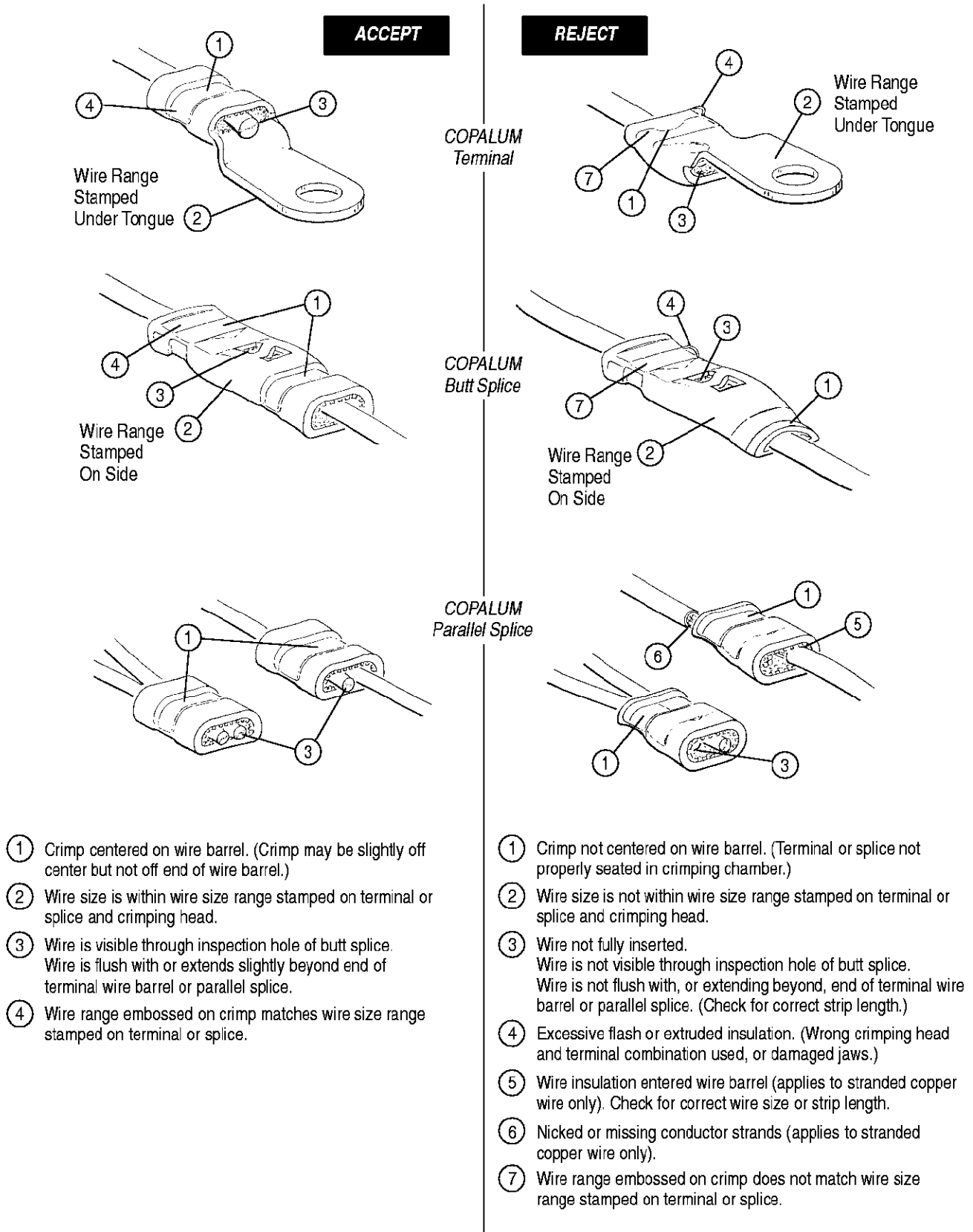

Figure 4

## 7. MAINTENANCE AND INSPECTION

**DANGER**

*To avoid personal injury, ALWAYS disconnect air supply from pneumatic tool before performing maintenance or inspection.*

It is recommended that a maintenance and inspection program be performed periodically to ensure dependable and uniform terminations. The pneumatic crimping head should be inspected once a month.

Frequency of inspection should be adjusted to suit your requirements through experience. Frequency of inspection depends on:

1. The care, amount of use, and handling of the crimping head.
2. The type and size of the product crimped.
3. The degree of operator skill.
4. The presence of abnormal amounts of dust and dirt.
5. Your own established standards.

Each crimping head is thoroughly inspected before packaging. Since there is the possibility of damage during shipment, new crimping heads should be inspected immediately upon arrival at your facility.

### 7.1. Daily Maintenance

It is recommended that each operator be responsible for the following steps of daily maintenance:

1. Remove dust, moisture, and other contaminants with a clean, soft brush, or a lint-free cloth. Do NOT use objects that could damage the head.
2. Make sure that all pins, rings, and other components are in place and secure.

**DANGER**

*To avoid personal injury and damage to the crimping head, make sure quick pins are fully tightened.*

3. Make certain all surfaces are protected with a thin coat of any good SAE 20 motor oil. Do NOT oil excessively.
4. When the crimping head is not in use, store it in a clean, dry area.

### 7.2. Periodic Inspection

Regular inspections should be performed by quality control personnel. A record of scheduled inspections should remain with the crimping head or be supplied to supervisory personnel responsible for the crimping head. Though recommendations call for at least one inspection a month, the frequency should be based

‡ Trademark of Dow Corning Corporation

on amount of use, working conditions, operator training and skill, and your established company policies. These inspections should include a visual inspection (Paragraph 7.3) and a crimping chamber inspection (Paragraph 7.5).

### 7.3. Visual Inspection

1. Remove all lubrication and accumulated film by immersing the crimping head in a suitable commercial degreaser that will not affect paint or plastic.
2. Make certain all components are in place. If replacements are necessary, refer to Section 8, REPLACEMENT AND REPAIR.
3. Check all bearing surfaces for wear. Make sure the rollers turn freely with minimal resistance. Replace worn parts.
4. Inspect crimp area for flattened, chipped, or broken areas. See Figure 5. Replace worn or damaged parts.

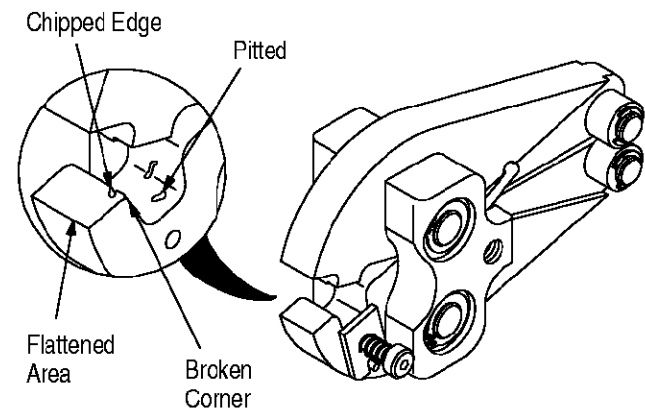

Figure 5

### 7.4. Lubrication

Lubricate all pins, pivot points, and bearing surfaces with a high quality grease. A recommendation is Molykote‡ grease, which is a commercially available lubricant. Lubricate according to the following schedule:

- Head used in daily production – lubricate daily
- Head used daily (occasional) – lubricate weekly
- Head used weekly – lubricate monthly

Wipe excess grease from crimping head, particularly from jaw closure areas. Grease transferred from jaw closure area onto certain terminations may affect the electrical characteristics of an application.

**Suggested Plug Gage Design for Inner Crimping Section**

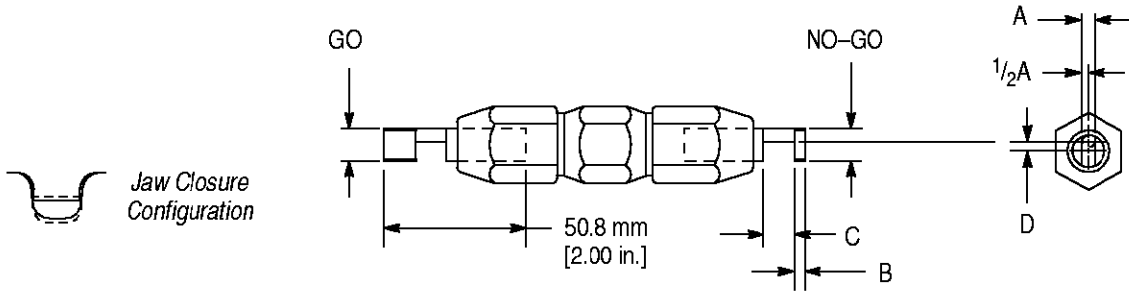

CRIMPING HEAD	GAGE ELEMENT DIMENSIONS (mm [IN.])					
	GO	NO-GO	"A"	"B"	"C"	"D"
662546-1	2.997-3.005	3.249-3.251	1.65	7.37	7.87	.610
1320369-1	[.1180-.1183]	[.1279-.1280]	[.065]	[.290]	[.310]	[.024]

**Suggested Plug Gage Design for Outer Crimping Section**

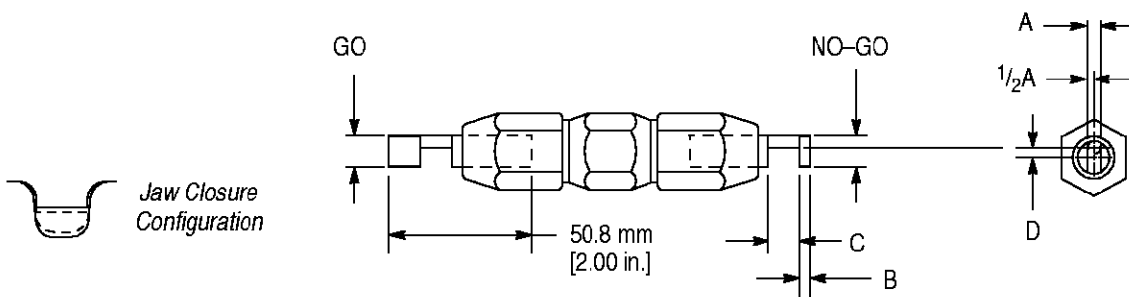

CRIMPING HEAD	GAGE ELEMENT DIMENSIONS (mm [IN.])					
	GO	NO-GO	"A"	"B"	"C"	"D"
662546-1	4.445-4.453	4.798-4.801	2.29	3.30	7.87	1.14
1320369-1	[.1750-.1753]	[.1889-1890]	[.090]	[.130]	[.310]	[.045]

Figure 6

**7.5. Gaging the Crimping Chamber**

This inspection requires the use of plug gages conforming to the dimensions shown in Figure 6. Tyco does not manufacture or market these gages.

**DANGER** Disconnect air supply and remove crimping head from pneumatic tool before inspecting crimping chamber.

1. Remove oil and dirt from the bottom of the jaw surfaces and plug gage element surfaces.
2. Close crimping jaws until they are bottomed, but not under pressure.
3. Align the GO element with the inner crimping section. Push element straight into the crimping chamber without using force. The GO element must pass completely through the crimping

chamber and then rotate freely in either direction. See Figure 7, Detail A.

4. Align the NO-GO element with the inner crimping section. Push element straight into the crimping chamber without using force. The NO-GO element must pass completely through the crimping chamber and then must *not* rotate. See Figure 7, Detail A.

5. Open the crimping jaws. Position the GO element on the lower jaw in the right outer crimping section so that the locator is in the notch of the element. Close the crimping jaws so that the lower jaw surface of the crimping chamber is seated on the element. The GO element must pass completely through the crimping chamber and then rotate freely in either direction. See Figure 7, Detail B.

6. Position the NO-GO element on the lower jaw in the right outer crimping section so that the locator is in the notch of the element. Close the crimping jaws so that the lower jaw surface of the crimping chamber is seated on the element. The NO-GO element must pass completely through the crimping chamber and then must *not* rotate. See Figure 7, Detail B.

7. Repeat Steps 5 and 6 for the left outer crimping section.

If the crimping chamber passes the gage inspection, the crimping head is considered dimensionally correct and should be lubricated with a THIN coat of any good SAE 20 motor oil. If the crimping chamber does not conform to the plug gage conditions, contact your local Field Representative or refer to Section 8.

For additional information about the use of a plug gage, see instruction sheet 408-7424.

### 8. REPLACEMENT AND REPAIR

Replacement parts and recommended spares are listed in Figure 8. The recommended spares should be stocked for immediate replacement.

Order replacement parts through your representative, or call 1-800-526-5142, or send a facsimile of your purchase order to 1-717-986-7605, or write to:

CUSTOMER SERVICE (38-35)  
TYCO ELECTRONICS CORPORATION  
P.O. BOX 3608  
HARRISBURG, PA 17105-3608

For repair service, please contact a representative at 1-800-526-5136.

### 9. REVISION SUMMARY

Since the previous release of this document, the following changes have been made:

Per EC 0990-0551-00

- Added new Pneumatic Crimping Head 1320369-1, updating text, charts, and Figure 8
- Updated document to corporate requirements
- Removed 4th Street address and replaced with phone number in Section 8

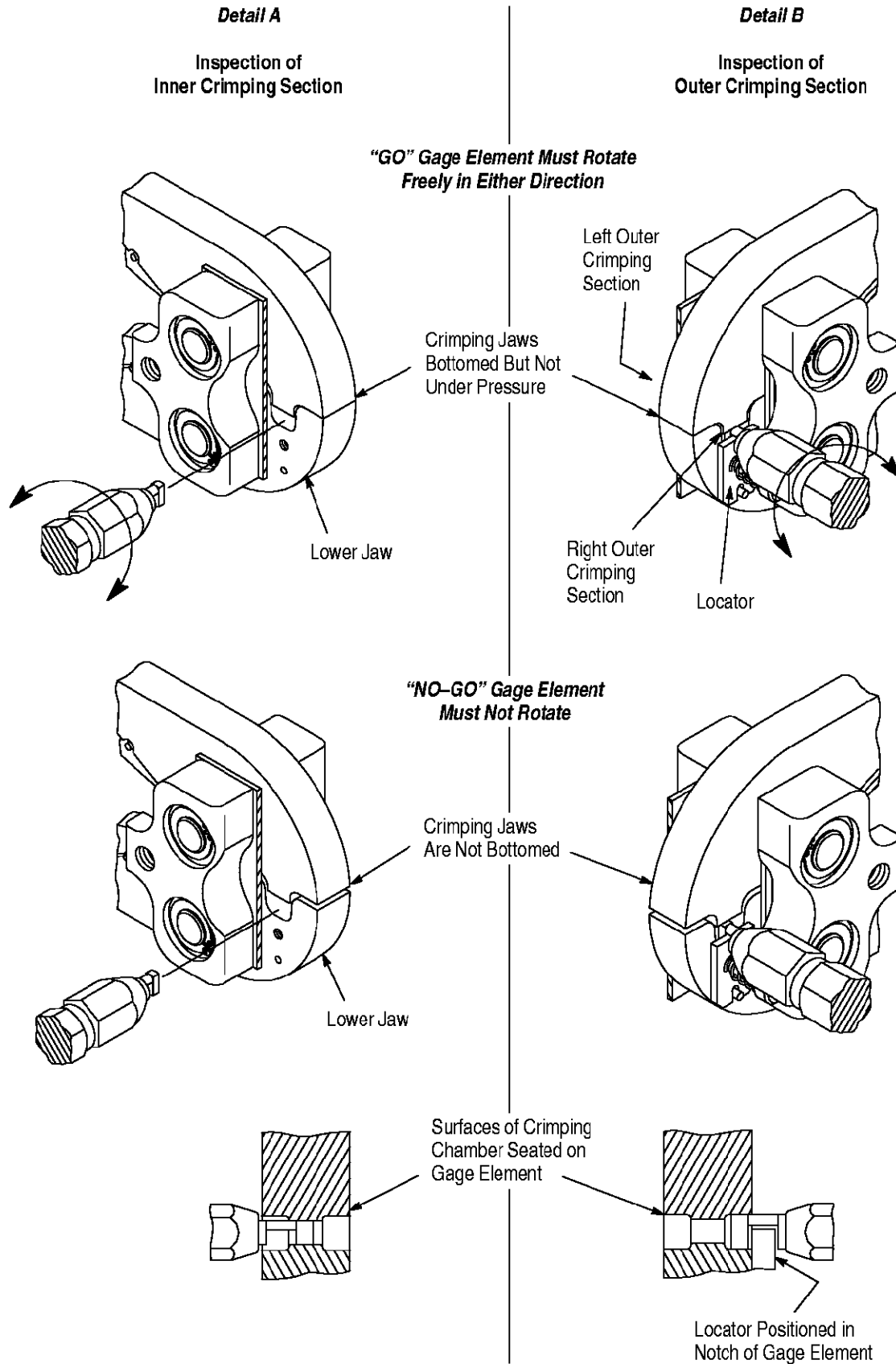
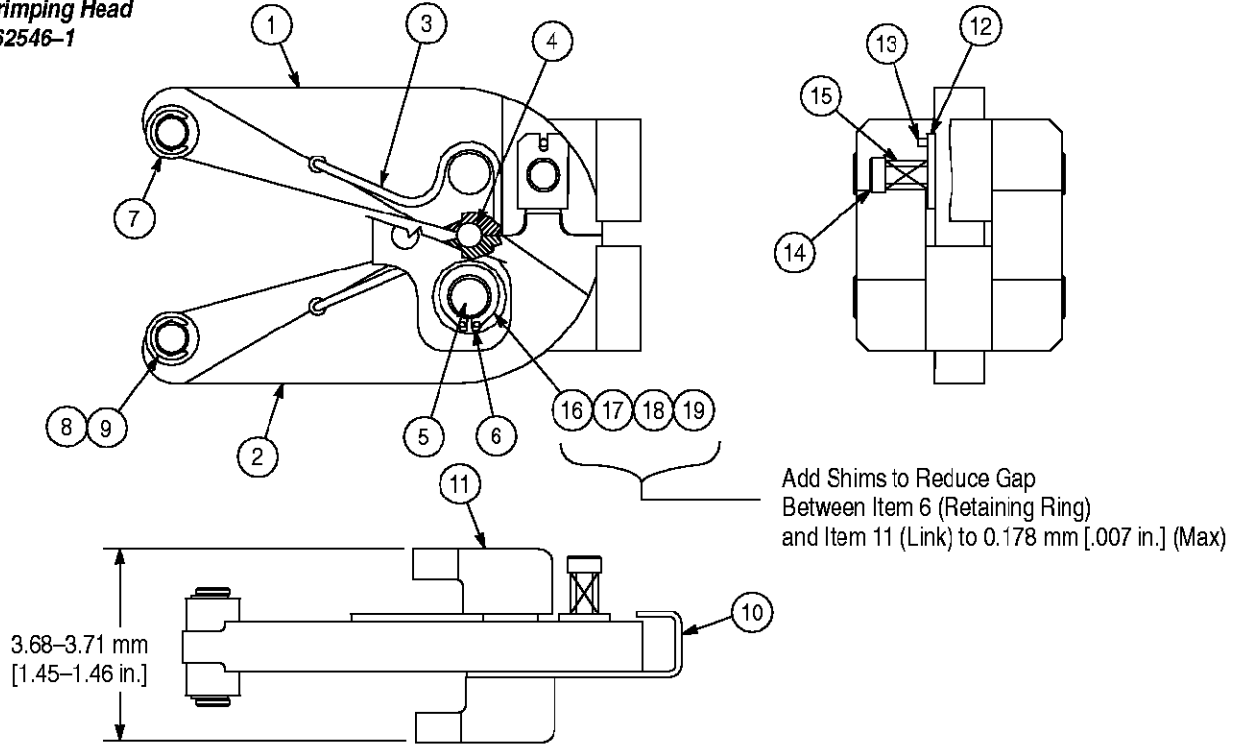

Figure 7



**Pneumatic  
Crimping Head  
662546-1**



**Pneumatic  
Crimping Head  
1320369-1**

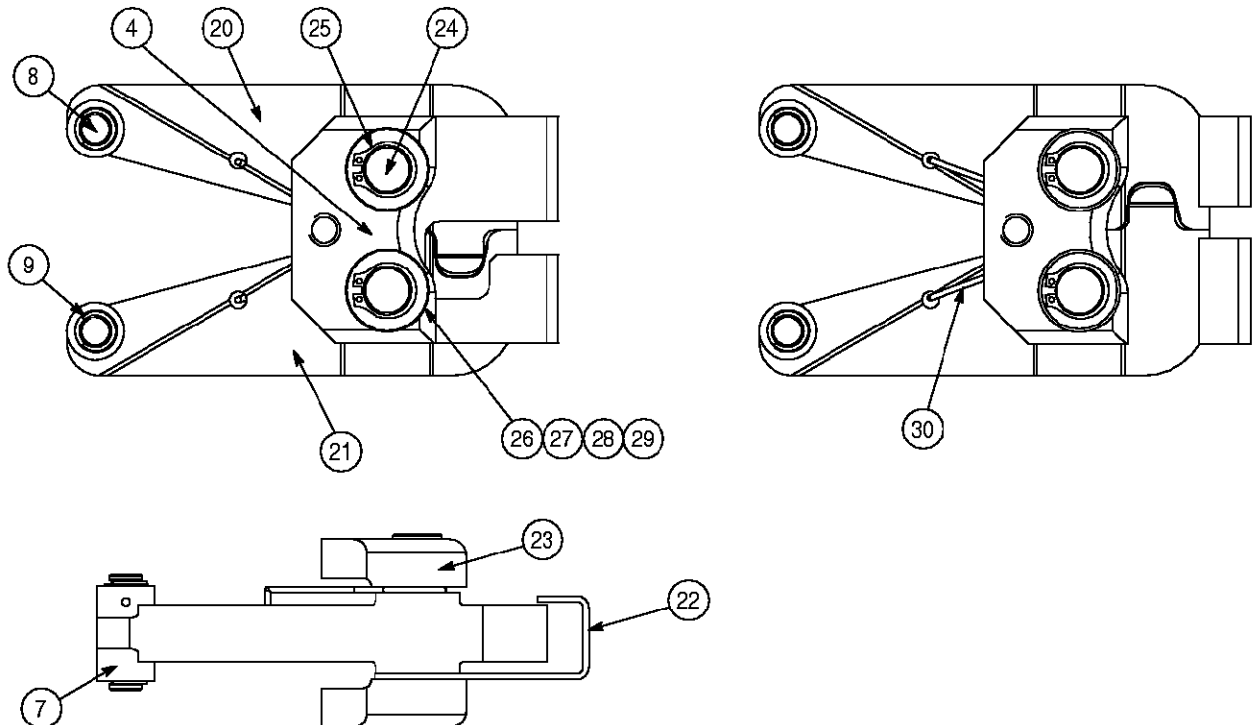

**CUSTOMER REPLACEMENT PARTS**

ITEM	PART NUMBER	DESCRIPTION	HEAD 662546-1 (QTY PER HEAD)	HEAD 1320369-1 (QTY PER HEAD)
1	662547-1	INDENTER	1	—
2	662548-1	ANVIL	1	—
3	679942-1	SPRING	1	—
4	23241-2	BALL, Steel	1	1
5	6-23629-0	PIN, Str Grv, .3125 Dia x 1.488	2	—
6	1-21048-0	RING, Retaining	4	—
7	314479-4	ROLLER	4	4
8	3-23620-3	PIN, Str Grv, .2500 Dia	2	2
9	21045-6	RING, Retaining	4	4
10	662549-1	GUARD	1	—
11	768521-6	LINK	2	—
12	189973-2	LOCATOR	1	—
13	21919-4	PIN, Dowel	1	—
14	22353-4	SCREW, Shoulder	1	—
15	2-25022-3	SPRING, Compression	1	—
16	301185-6	SHIM, 0.20 mm [.008 in.]	as required	—
17	301185-7	SHIM, 0.25 mm [.010 in.]	as required	—
18	301185-8	SHIM, 0.31 mm [.012 in.]	as required	—
19	301185-9	SHIM, 0.38 mm [.015 in.]	as required	—
20	1320368-1	ANVIL	—	1
21	1320367-1	INDENTER	—	1
22	1320370-1	GUARD	—	1
23	1320371-1	LINK	—	2
24	5-23630-2	PIN, Str Grv, .378 Dia x 1.508	—	2
25	1-21048-3	RING, Retaining	—	4
26	1-301185-7	SHIM, 0.20 mm [.008 in.]	—	as required
27	1-301185-8	SHIM, 0.25 mm [.010 in.]	—	as required
28	1-301185-9	SHIM, 0.31 mm [.012 in.]	—	as required
29	2-301185-0	SHIM, 0.38 mm [.015 in.]	—	as required
30	679942-2	SPRING	—	1

Figure 8