

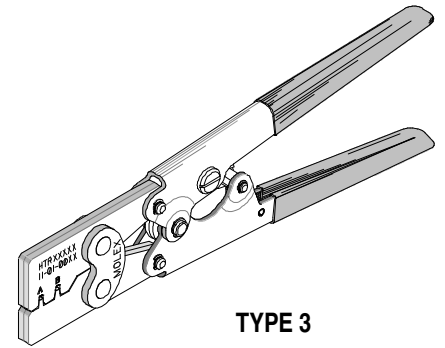

**Hand Crimp Tool
Specification Sheet
Order No. 11-01-0101
Engineering No. HTR2450A**



TYPE 3

FEATURES

- Simple trouble-free full cycle mechanism assures consistent complete terminations
- All crimp cavities are fully machined in high carbon steel, then heat treated

SCOPE

Products: Flat Blade Female Crimp Terminal, 14-20 AWG.

Terminal Series No.	Terminal Order No.				Wire Size		Insulation Diameter Maximum		Strip Length	
	Loose Piece		▪ Reel		AWG	mm ²	mm	In.	mm	In.
1508	05-06-0118		05-06-0117		14-18	2.00-0.80	3.56	1.40	3.96-5.35	.156-.218
2176	05-06-0302	05-06-0304	05-06-0301	05-06-0303	14-20	2.00-0.50	3.56	1.40	3.55-4.74	.140-.187
2576	05-06-0306		05-06-0305		14-20	2.00-0.50	3.56	1.40	3.55-4.74	.140-.187

▪ Customer to cut off terminal from reel: 0.94mm(.037") maximum Cut-off Tab.

DEFINITION OF TERMS

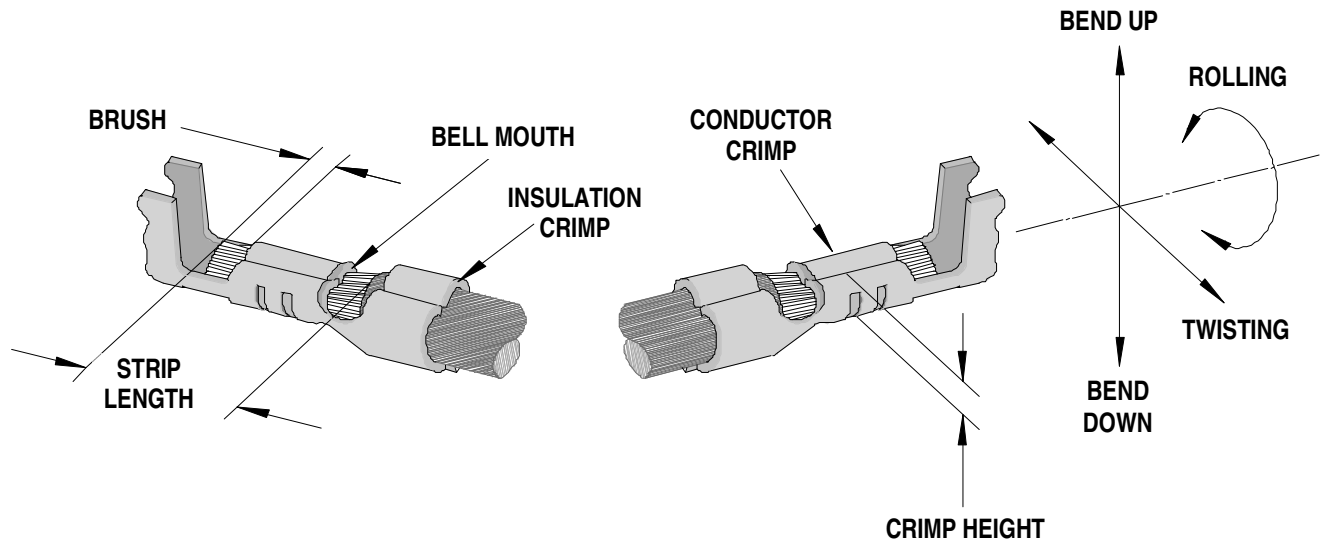

The above terminal drawing is a generic terminal representation. It is not an image of a terminal listed in the scope.

CONDITIONS:

After crimping, the conductor profiles should measure the following (see notes on page 4).

Terminal Series No.	Wire Size		Solder Specification				Pull Force Minimum		Profile	
			Conductor Crimp							
	AWG	mm ²	Height (Ref)		Width (Ref)		N	Lb.	A	B
1508	14	2.00	1.07-1.27	.042-.050	2.34	.092	177.9	40.00		X
	16	1.30	1.07-1.27	.042-.050	2.34	.092	155.7	35.00		X
	18	0.80	1.07-1.27	.042-.050	2.34	.092	111.2	25.00	X	
2176	14	2.00	1.07-1.27	.042-.050	2.34	.092	177.9	40.00		X
	16	1.30	1.07-1.27	.042-.050	2.34	.092	155.7	35.00		X
	18	0.80	1.07-1.27	.042-.050	2.34	.092	111.2	25.00	X	
	18 DBL	0.80(2)	1.07-1.27	.042-.050	2.34	.092	111.2	25.00		X
	20	0.50	1.07-1.27	.042-.050	2.34	.092	66.7	15.00	X	
	22	0.35	1.07-1.27	.042-.050	2.34	.092	53.4	12.00	X	
2576	14	2.00	1.07-1.27	.042-.050	2.34	.092	177.9	40.00		X
	16	1.30	1.07-1.27	.042-.050	2.34	.092	155.7	35.00		X
	18	0.80	1.07-1.27	.042-.050	2.34	.092	111.2	25.00	X	
	18 DBL	0.80(2)	1.07-1.27	.042-.050	2.34	.092	111.2	25.00		X
	20	0.50	1.07-1.27	.042-.050	2.34	.092	66.7	15.00	X	
	22	0.35	1.07-1.27	.042-.050	2.34	.092	53.4	12.00	X	

Notes:

- Solder crimp heights are supplied for tool calibration only. To verify tool calibration, insert solder slug (5% tin and 95% lead) into the crimping profile of the hand tool. Close the hand tool completely, as if a terminal and wire combination is present. Measure the solder for crimp height and width. See Figure 1. Actual crimp heights will vary with every terminal, conductor, and insulation combinations.

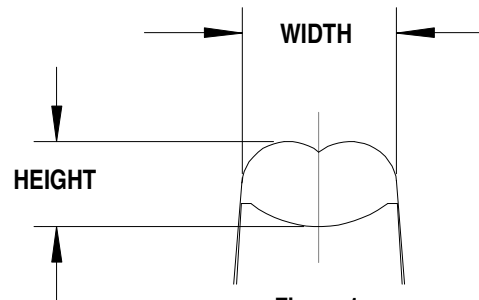

Figure 1

- Pull force should be used as the final criteria for an acceptable crimp. Pull force is measured with no influence from the insulation crimp. The insulation should be stripped long (1/2 in.) so the insulation grips on the terminal do not grip the wire insulation or the conductor. Refer to Molex Quality Crimping Handbook 63800-0029 for additional information on crimping and crimp testing.

OPERATION

Open the tool by squeezing the handles together, at the end of the closing stroke, the ratchet mechanism will release the handles, and the hand tool will spring open.

Crimping Terminals

1. Select the proper die profile (A or B) for the correct terminal. Insert the terminal from the back of the hand tool until the insulation tabs or grips are flush with the outside face of the insulation crimp jaws. See Figure 1.

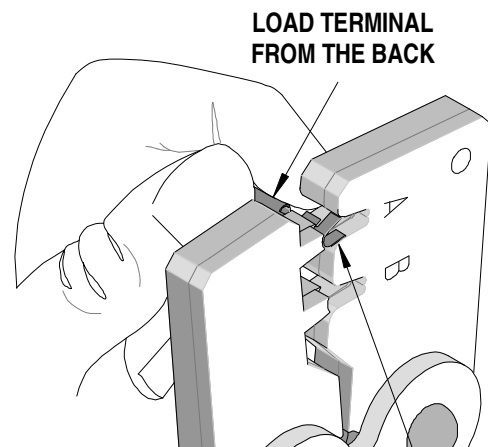

Figure 1

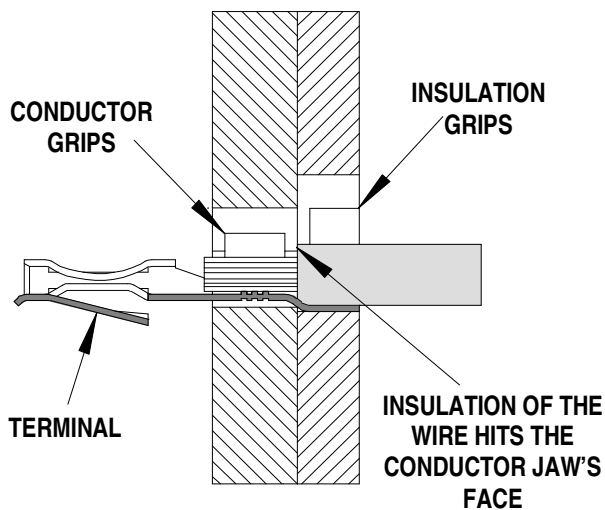

Figure 2

2. Close the jaws just enough to hold the terminal in place.
3. Insert the properly stripped wire in through the insulation tabs or grips until the insulation hits the conductor jaw face. See Figure 2.
4. Close the tool until the ratchet releases.
5. Straighten the terminal if necessary, then release the jaws and carefully remove the crimped terminal.

Note: The tamper proof ratchet action will not release the tool until it has been fully closed.

Maintenance

It is recommended that each operator of the tool be made aware of, and responsible for, the following maintenance steps:

1. Remove dust, moisture, and other contaminants with a clean brush, or soft, lint free cloth.
2. Do not use any abrasive materials that could damage the tool.
3. Make certain all pins; pivot points and bearing surfaces are protected with a thin coat of high quality machine oil. Do not oil excessively.
4. When tool is not in use, keep the handles closed to prevent objects from becoming lodged in the crimping dies, and store the tool in a clean, dry area.

Miscrimps or Jams

Should this tool ever become stuck or jammed in a partially closed position, **Do Not force the handles open or closed.** The tool will open easily by lifting the ratchet release lever (See Figure 4).

How to Adjust Tool Crimp Force (See Figure 3)

It may be necessary over the life of the tool to adjust tool-crimping force. Listed below are the steps required to adjust the crimping force of the hand tool to obtain proper crimp conditions:

1. Loosen the stud nut on the back of the handle.
2. With a screwdriver in the slot on the other side of the stud, adjust the force. Clockwise will increase the force, counter clockwise will decrease the force.
3. Retighten the nut.
4. Check the crimp specifications after tool force adjustment.

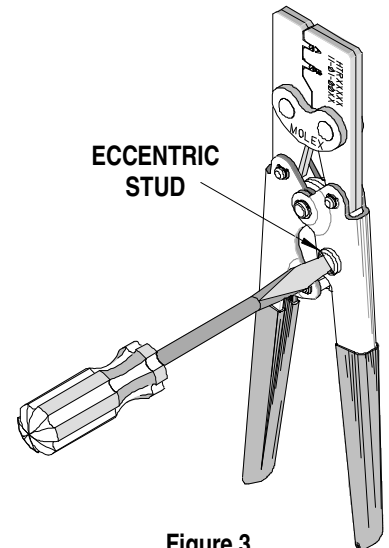

Figure 3

Warranty

This tool is for electrical terminal crimping purposes only. This tool is made of the best quality materials. All vital components are long life tested. All tools are warranted to be free of manufacturing defects for a period of 30 days. Should such a defect occur, we will repair or exchange the tool free of charge. This repair or exchange will not be applicable to altered, misused, or damaged tools. This tool is designed for hand use only. Any clamping, fixturing, or use of handle extensions voids this warranty.

CAUTION: Repetitive use of this tool should be avoided.

CAUTIONS:

1. Manually powered hand tools are intended for low volume or field repair. This tool is **NOT** intended for production use. Repetitive use of this tool should be avoided.
2. Insulated rubber handles are not protection against electrical shock.
3. Wear eye protection at all times.
4. Use only the Molex terminals specified for crimping with this tool.

Notes:

1. This tool should only be used for the terminals and wire gauges specified on this sheet.
2. This tool is not adjustable for crimp height, however crimp force is adjustable (See instructions above). Variations in tools, terminals, wire stranding and insulation types may affect crimp height.
3. This tool is intended for standard conductor sizes. It may not give a good insulation crimp support for all insulation sizes.
4. Molex does not repair hand tools (see warranty above) The replacement parts listed are the only parts available for repair. If the handles or crimp tooling is damaged or worn, a new tool must be purchased.
5. Pull force should be used as the final criteria for an acceptable crimp. Pull force is measured with no influence from the insulation crimp. The insulation should be stripped long (1/2 in.) so the insulation grips on the terminal do not grip the wire insulation or the conductor. Refer to Molex Quality Crimping Handbook 63800-0029 for additional information on crimping and crimp testing.
6. Molex does not certify crimp hand tools.

CAUTION: Molex crimp specifications are valid only when used with Molex terminals and tooling.

PARTS LIST

Item	Order No.	Order No.	Description	Quantity
1	64000-0073	64000-0073	Repair Kit (Springs, Pins and E-Rings)	1

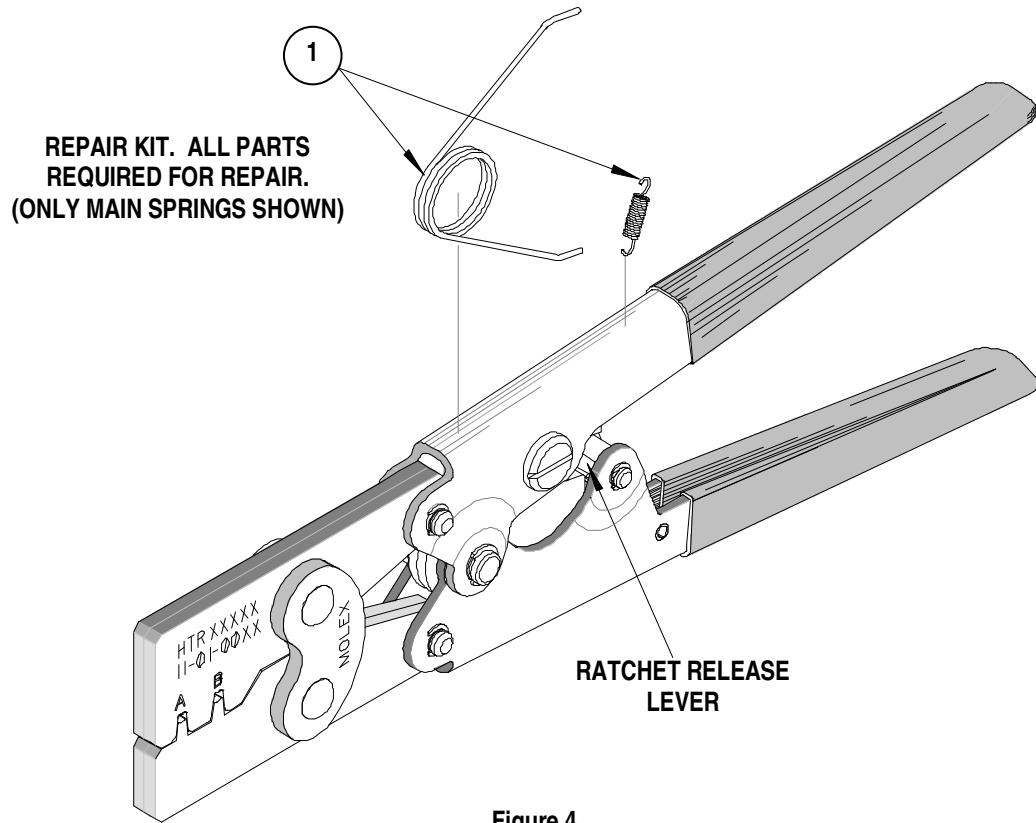

Americas Headquarters
Lisle, Illinois 60532 U.S.A.
1-800-78MOLEX
amerinfo@molex.com

Far East North Headquarters
Yamato, Kanagawa, Japan
81-462-65-2324
feninfo@molex.com

Far East South Headquarters
Jurong, Singapore
65-6-268-6868
fesinfo@molex.com

European Headquarters
Munich, Germany
49-89-413092-0
eurinfo@molex.com

Corporate Headquarters
2222 Wellington Ct.
Lisle, IL 60532 U.S.A.
630-969-4550
Fax: 630-969-1352

Visit our Web site at <http://www.molex.com>