

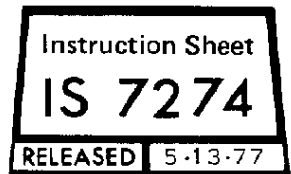

APPLICATION AND MAINTENANCE
FOR AMP★ HAND CRIMPING TOOL 90189-1



Section I of this instruction sheet provides application procedures for AMP hand crimping tools.

Section II provides maintenance and inspection procedures for AMP hand crimping tools.

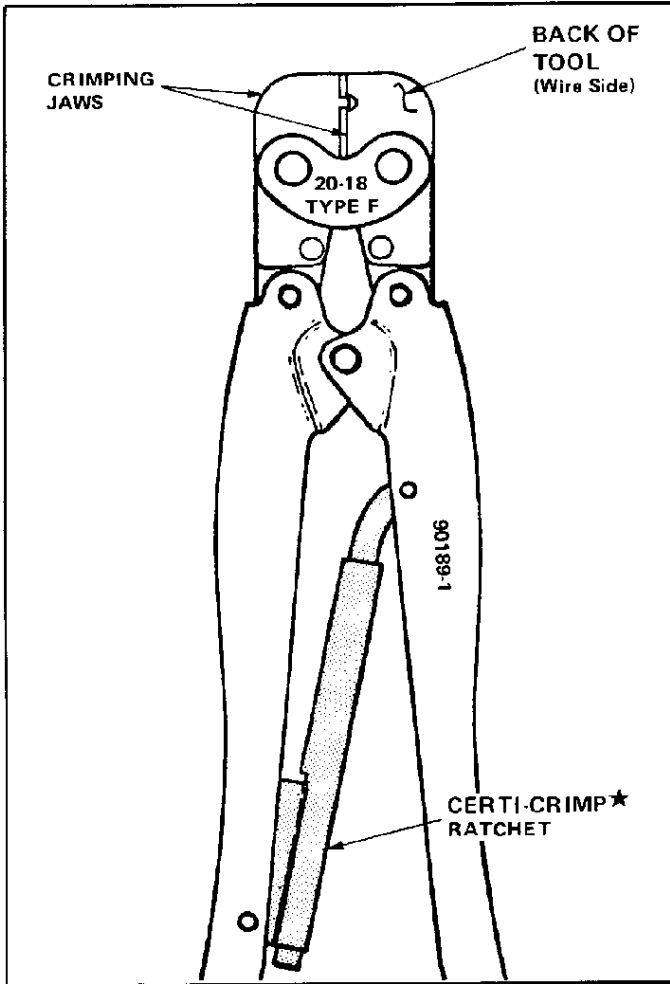

Fig. I-1

SECTION I APPLICATION

I-1. INTRODUCTION

AMP Hand Crimping Tool 90189-1 is designed for crimping the AMP Taper Pin terminals listed in Figure I-2. Read these instructions thoroughly before crimping any terminals.

NOTE All dimensions presented on this instruction sheet are in inches, unless otherwise stated.

I-2. DESCRIPTION

The FRONT OF TOOL has the "AMP" marking on the link. The BACK OF TOOL (Wire Side), into which the wire is inserted, has the wire size marked on the link.

★TRADEMARK OF AMP INCORPORATED

This tool features a locator/insulation stop, a terminal support, and a CERTI-CRIMP ratchet.

The locator/insulation stop has two functions. First, it positions the terminal in the crimping jaws, and second, it aids in locating the wire in the terminal. In use, it rests in the terminal locator slot (see Figures I-2 and I-3.)

The terminal support prevents the terminal from bending during the crimping operation.

The CERTI-CRIMP ratchet ensures full crimping of the terminal. Once engaged, the ratchet will not release until the tool handles have been FULLY closed.

CAUTION The crimping jaws bottom before the CERTI-CRIMP ratchet releases. This is a design feature that ensures maximum electrical and tensile performance of the crimp. Do NOT re-adjust the ratchet.

I-3. CRIMPING PROCEDURE

Refer to the chart in Figure I-2 and select wire within the specified size and insulation diameter. Strip the wire to the length indicated — do NOT cut or nick the wire strands.

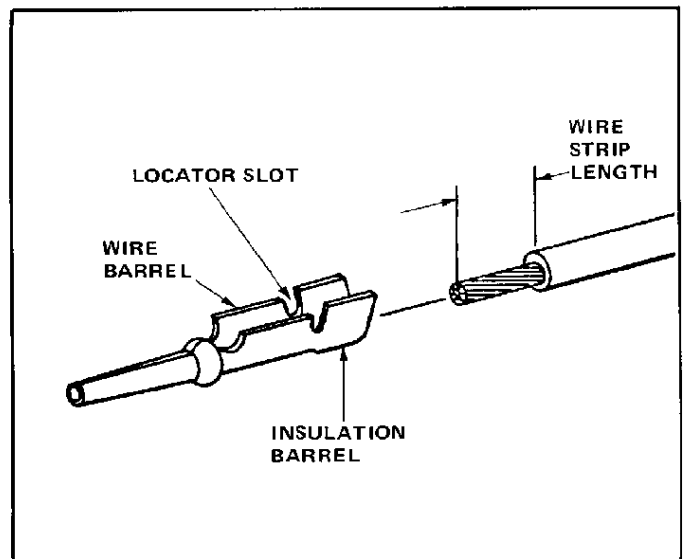

SIZE (AWG)	WIRE		TERMINAL	
	INSUL DIA	STRIP LENGTH	LOOSE PIECE	STRIP
20 to 18	.060 to .080	7/32 (.219)	42231 66201	42229 66200

Fig. I-2

Copyright 1966, 1977 by AMP Incorporated, Harrisburg, Pa. All International Rights Reserved. AMP Incorporated products covered by U.S. and Foreign patents and/or patents pending.

Select a proper loose piece terminal. Refer to Figure I-3 and proceed as follows:

1. Hold tool so BACK (Wire Side) is facing you.
2. Make sure ratchet is released – squeeze tool handles together and allow them to open FULLY.
3. Position terminal in crimping jaws so locator enters locator slot in terminal.

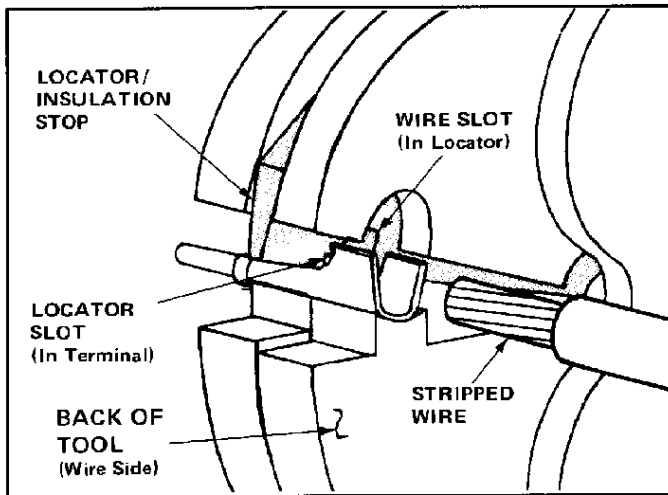

Fig. I-3

4. Hold terminal in place and squeeze tool handles together until crimping jaws close just enough to retain terminal. Do NOT deform insulation barrel or wire barrel.
5. Insert a properly stripped wire through wire slot in locator and into wire barrel of terminal until insulation butts against locator/insulation stop.
6. Holding wire in place, squeeze tool handles together until ratchet releases.
7. Allow tool handles to open FULLY and remove crimped terminal from tool.

I-4. DAILY MAINTENANCE

Remove all foreign particles with a clean, soft brush, or a clean, soft, lint-free cloth. Make sure the proper retaining pins are in place, and secured with the proper retaining rings. If foreign matter cannot be removed easily, or if the proper replacement parts are not available, return the tool to your supervisor.

Make certain all pivot points and bearing surfaces are protected with a THIN coat of SAE No. 20 motor oil. Do NOT oil excessively. When the tool is not in use, keep the handles closed to prevent objects from becoming lodged between the crimping jaws, and store the tool in a clean dry area.

Section I of this instruction sheet provides application procedures for AMP hand crimping tools.

Section II provides maintenance and inspection procedures for AMP hand crimping tools.

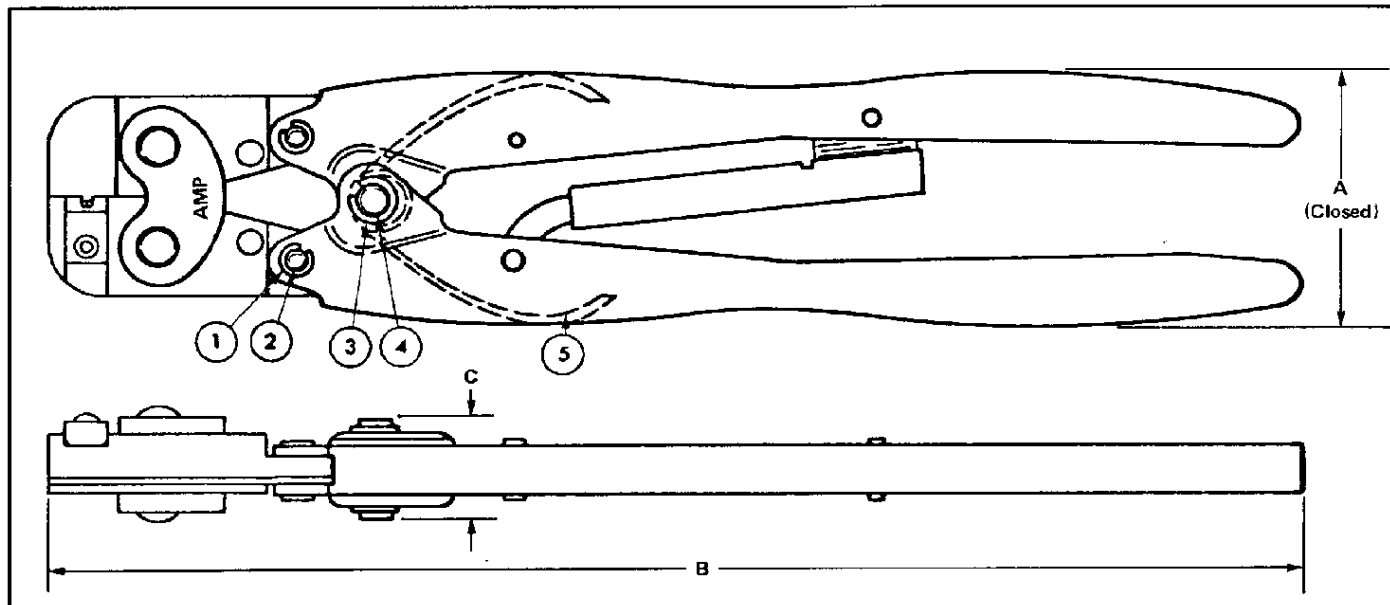

TOOL SPECIFICATIONS		REPLACEMENT PARTS KIT 125218-4				
DIMENSION (Max)	WEIGHT	ITEM	PART NUMBER	DESCRIPTION	QTY PER KIT	
A	3	1	21045-3	RING-Retaining	120 to 130	
B	11		300432	PIN-Retaining (.187D x .521L)	15	
C	7/8		21045-6	RING-Retaining	25 to 30	
Engineering Approval		Date	4	300449	PIN-Retaining (.250D x .838L)	10
			5	39364	SPRING-Handle	10

Fig. II-1

SECTION II MAINTENANCE/INSPECTION

II-1. TOOL CERTIFICATION

These instructions have been approved by AMP Design, Production, and Quality Control Engineers to provide documented maintenance and inspection procedures in accordance with AMP Corporate Policy Number 3-3. Through AMP test laboratories and the inspection of production assembly, the procedures described herein have been established to assure quality and reliability of AMP hand crimping tools.

Customer replaceable parts are listed in Figure II-1. A complete inventory should be stocked and controlled to prevent lost time when replacement of parts is deemed necessary. When ordering, order the replacement parts kit listed in Figure II-1.

II-2. INSPECTION PROCEDURES

A. Daily Maintenance

It is recommended that each operator of the tool be made aware of – and responsible for – the following four steps of daily maintenance:

1. Remove dust, moisture, and other contaminants with a clean brush, or a soft, lint-free

cloth. Do NOT use objects that could damage the tool.

2. Make sure the proper retaining pins are in place and secured with the proper retaining rings.

3. Make certain all pins, pivot points, and bearing surfaces are protected with a THIN coat of good SAE No. 20 motor oil. Do NOT oil excessively.

4. When the tool is not in use, keep the handles closed to prevent objects from becoming lodged in the crimping jaws and store the tool in a clean, dry area.

B. Periodic Inspection

Regular inspections should be performed by quality control personnel. A record of scheduled inspections should remain with the tool and/or supplied to supervisory personnel responsible for the tool. Though recommendations call for at least one inspection a month, the inspection frequency should be based on the amount of use, ambient working conditions, operator training and skill, and established company standards. These inspections should be performed in the following sequence:

B-1. Visual Inspection

1. Remove all lubrication and accumulated film by immersing the tool (handles partially closed) in a suitable commercial degreaser that will not effect paint or plastic material.
2. Make certain all retaining pins are in place and secured with retaining rings. If replacements are necessary, refer to parts listed in Figure II-1.
3. Close the tool handles until the ratchet releases, then allow handles to open freely. If they do not open quickly and fully, the spring is defective and must be replaced.
4. Inspect the head assembly, with special emphasis on checking for worn, cracked, or broken jaws. If damage to any part of the head assembly is evident, return the tool to AMP for evaluation and repair (see Paragraph II-3, REPAIR).

B-2. Crimp Height Inspection

This inspection incorporates the use of a micrometer with a modified anvil as shown in Figure II-2. We recommend the modified micrometer (Crimp Height Comparator RS-1019-5L) which can be purchased from:

York Machinery & Supply Co. VALCO
 20 North Penn St. or 1410 Stonewood Dr.
 York, PA 17401 Bethlehem, PA 18017

Proceed as follows:

1. Refer to the chart in Figure II-2, and select a terminal and a wire (maximum size) for the tool.
2. Refer to Paragraph I-3, CRIMPING PROCEDURE, and crimp the terminal accordingly.
3. Using a crimp height comparator, measure the wire barrel crimp height as shown in Figure II-2. If the crimp height conforms to that shown in the chart the tool is considered dimensionally correct. If not, return the tool to AMP for evaluation and repair (see Paragraph II-3). For additional information concerning the use of the crimp height comparator, refer to AMP Instruction Sheet IS 7424.

B-3. CERTI-CRIMP Ratchet Inspection

Obtain a .001-in. shim that is suitable for checking the clearance between the bottoming surfaces of the crimping dies.

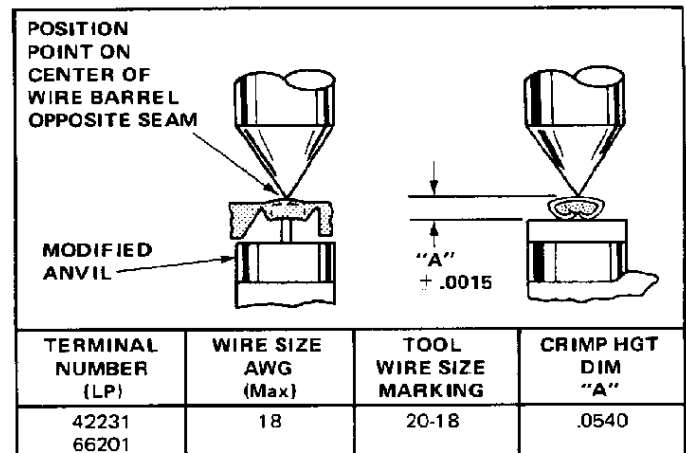

Fig. II-2

Proceed as follows:

1. Select a terminal and a wire (maximum size) for the tool (see Figure II-2).
2. Position the terminal and wire between the crimping jaws according to Paragraph I-3, CRIMPING PROCEDURE (Steps 1 through 5). Holding the wire in place, squeeze the tool handles until the CERTI-CRIMP ratchet releases. HOLD the tool handles in this position, maintaining just enough tension to keep the jaws closed.
3. Check the clearance between the bottoming surfaces of the crimping jaws. If the clearance is .001 in. or less, the ratchet is satisfactory. If clearance exceeds .001 in., the ratchet is out of adjustment and must be repaired (see Paragraph II-3).

If the tool conforms to these inspection procedures, lubricate it with a THIN coat of good SAE No. 20 motor oil and return it to service.

II-3. REPAIR

Parts other than those specified in Figure II-1 must be replaced by AMP to insure certification of the tool. When repair is necessary, return the tool with a written description of the problem to:

AMP Incorporated
 Customer Repair
 1523 North 4th Street
 Harrisburg, Pennsylvania 17105

or a wholly owned subsidiary of AMP Incorporated.