

**PROPER USE GUIDELINES**

Cumulative Trauma Disorders can result from the prolonged use of manually powered hand tools. Hand tools are intended for occasional use and low volume applications. A wide selection of powered application equipment for extended-use, production operations is available.

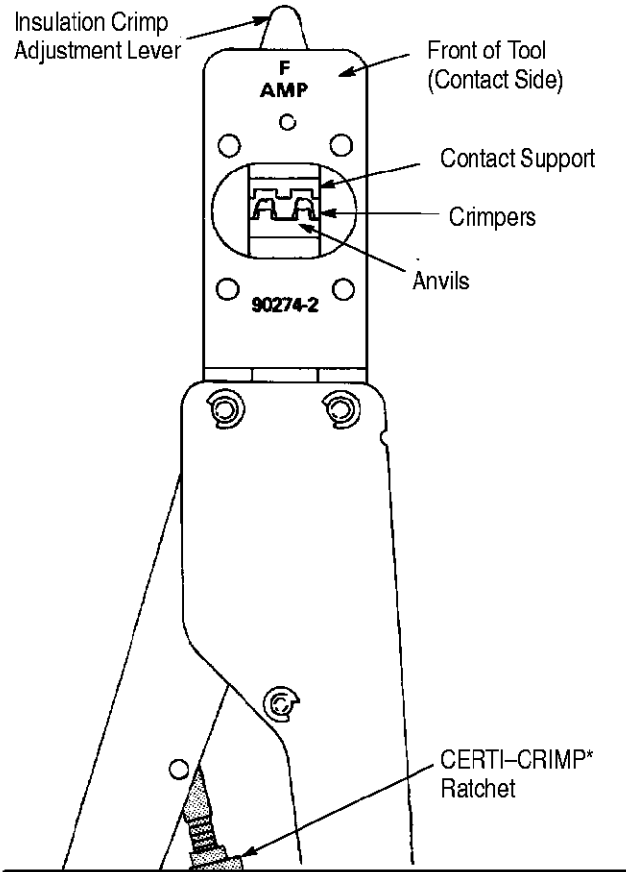

Figure 1

The insulation crimp adjustment lever is used to regulate the crimp height of the contact insulation barrel. For detailed information on using the adjustment lever, refer to Section 4, INSULATION CRIMP ADJUSTMENT.

The contact support prevents the contact from bending during the crimping operation.

The contact locator/insulation stop has two functions. First, it is used to position the contact between the crimping dies, and second, it aids in locating the wire in the contact. In use, it rests in the contact locator slot. See Figures 2 and 3.

The CERTI-CRIMP ratchet ensures full crimping of the contact. Once engaged, the ratchet will not release until the tool handles have been fully closed.

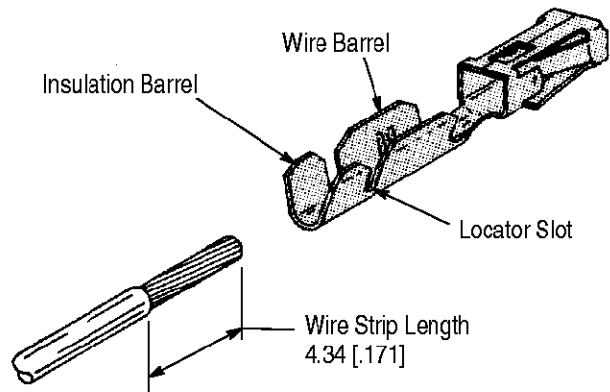

Figure 2

**1. INTRODUCTION**

AMP\* Hand Crimping Tool 90274-2 is designed to crimp the AMPMODU\* MOD I loose-piece (LP) contacts listed in Figure 2. Read these instructions thoroughly before crimping any contacts.

**NOTE** All dimensions on this document are in metric units [with U.S. customary units in brackets]. Figures and illustrations are for identification only and are not drawn to scale.

Reasons for reissue of this instruction sheet are provided in Section 7, REVISION SUMMARY.

**2. DESCRIPTION** (Figures 1 and 3)

This tool features two fixed dies (crimpers), two movable dies (anvils), an insulation crimp adjustment lever, a contact support, a contact locator/insulation stop, and a CERTI-CRIMP ratchet.

WIRE		CONTACT NO.		CRIMP SECTION (Wire Size Marking)
SIZE (AWG)	INSUL DIA	LP	STRIP	
22 to 20	1.30 to 2.29 [.051 to .090]	87026	87023	22-20
		87027	87024	
		102103	102099	
		102104	102100	
18	1.30 to 2.29 [.051 to .090]	87026	87023	18
		87027	87024	
		102103	102099	
		102104	102100	

### 3. CRIMPING PROCEDURE

Refer to the chart in Figure 2 and select wire within the specified wire size and insulation diameter. Strip the wire to the length indicated—do NOT cut or nick the wire strands.

Notice that each crimp section has the applicable wire size stamped above it. Use this marking and the wire size that you are using to determine the proper crimp section.

Select the applicable loose-piece contact and proceed as follows:

1. Hold the tool so that the back (wire side) is facing you.
2. Make sure that the ratchet is released. Squeeze the tool handles together and allow them to open fully.
3. Looking straight into the back of the tool, insert the contact (insulation barrel first) into the front of the appropriate crimp section. See Figure 3.
4. Position the contact in the crimpers so that the locator/insulation stop enters the locator slot of the contact.
5. Hold the contact in this position and squeeze the tool handles together until the insulation anvil starts entry into the insulation crimper. Do NOT deform the insulation barrel or wire barrel.

6. Insert a properly-stripped wire through the wire slot of the locator and into the wire barrel of the contact until the wire insulation butts against the locator/insulation stop.

7. While holding the wire in place, squeeze the tool handles together until the ratchet releases.

8. Allow the tool handles to open fully and remove the crimped contact.

### 4. INSULATION CRIMP ADJUSTMENT

The insulation barrel crimp height is regulated by the insulation crimp adjustment lever. To determine the proper setting, test crimp a contact using the setting which approximates the insulation size: (1) small, (2) medium, or (3) large. If the crimped insulation barrel is too tight or too loose, change the setting accordingly. The crimp should hold the insulation firmly without cutting into it.

### 5. MAINTENANCE/INSPECTION

#### 5.1. Daily Maintenance

Remove all foreign particles with a clean, soft brush or a clean, soft, lint-free cloth. Make sure the proper retaining pins are in place and are secured with the proper retaining rings. If foreign matter cannot be removed easily, or if the proper replacement parts are not available, return the tool to your supervisor.

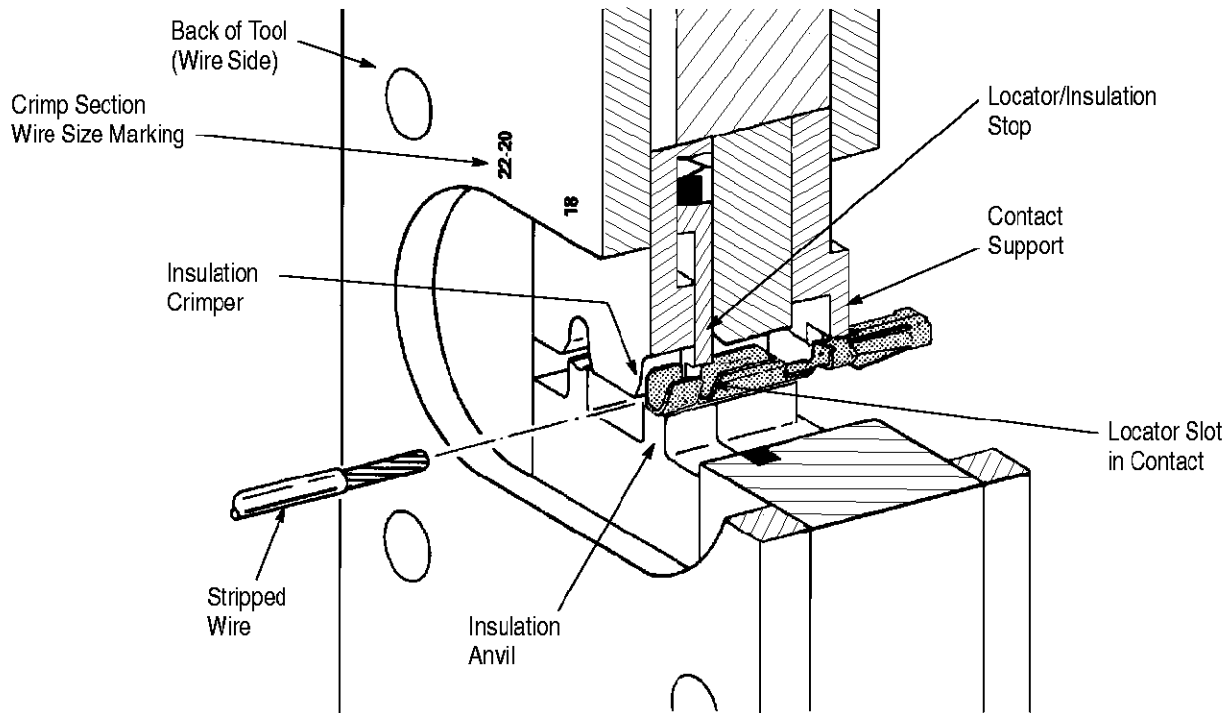

Figure 3

Make sure all pivot points and bearing surfaces are protected with a thin coat of any good SAE 20 motor oil. Do NOT oil excessively. When the tool is not in use, keep the handles closed to prevent objects from becoming lodged between the dies, and store the tool in a clean, dry area.

**5.2. Periodic Inspection**

Regular inspections should be performed by quality control personnel. A record of scheduled inspections should remain with the tool and/or be supplied to the supervisory personnel responsible for the tool. Though recommendations call for at least one inspection a month, the inspection frequency should be based on the amount of use, ambient working conditions, operator training and skill, and established company standards. These inspections should be performed in the following sequence:

**A. Visual Inspection**

1. Remove all lubrication and accumulated film by immersing the tool (handles partially closed) into a suitable degreaser that will not affect paint or plastic material.
2. Make certain all retaining pins are in place and are secured with the proper retaining rings. If replacements are necessary, refer to Figure 5.
3. Close the tool handles until the ratchet releases, and then allow the handles to open freely. If they do not open quickly and fully, then the spring is defective and must be replaced (see Section 6, REPLACEMENT AND REPAIR).
4. Inspect the head assembly, with special emphasis on checking for worn, cracked, or broken crimping dies. If damage to any part of the head is evident, return the tool for evaluation and repair (see Section 6, REPLACEMENT AND REPAIR).

**B. Crimp Height Inspection**

This inspection requires the use of micrometer, with a modified anvil, as shown in Figure 4. The Crimp Height Comparator RS-1019-5LP is recommended and is available from:

Shearer Industrial Supply Co.                      VALCO  
20 North Penn Street                      or                      1410 Stonewood Drive  
York, PA 17401-1014                      Bethlehem, PA 18017-3527

Proceed as follows:

1. Refer to the chart in Figure 4 and select a contact and a wire (maximum size) for each crimp section.
2. Refer to Section 3, CRIMPING PROCEDURE, and crimp the contact(s) accordingly.

3. Using a crimp height comparator, measure the wire barrel crimp height as shown in Figure 4. If the crimp height conforms to that shown in the chart, the tool is considered dimensionally correct. If not, return the tool for evaluation and repair (refer to Section 6, REPLACEMENT AND REPAIR).

For additional information concerning the use of the crimp height comparator, refer to Instruction Sheet 408-7424.

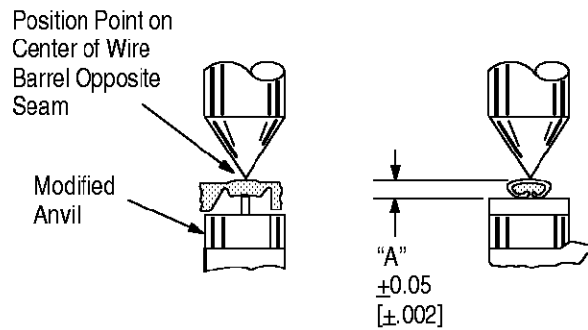

CONTACT NUMBER (LP)	WIRE SIZE AWG (Max.)	CRIMP SECT (Wire Size Marking)	CRIMP HEIGHT DIM. "A"
87026	20	22-20	0.84 [.033]
87027			
102103	18	18	1.07 [.042]
102104			

Figure 4

**C. CERTI-CRIMP Ratchet Inspection**

Obtain a 0.025 [.001] shim that is suitable for checking the clearance between the bottoming surfaces of the crimping dies. Proceed as follows:

1. Select a contact and *maximum* size wire for the hand tool.
2. Position the contact and wire between the crimping dies, as described in Section 3, CRIMPING PROCEDURE.
3. Holding the wire in place, squeeze the tool handles together until the CERTI-CRIMP ratchet releases. Hold the handles in this position, maintaining just enough tension to keep the dies closed.
4. Check the clearance between the bottoming surfaces of the crimping dies. If the clearance is 0.025 [.001] or less, the ratchet is satisfactory. If the clearance exceeds 0.025 [.001], the ratchet is out of adjustment and must be repaired.

**6. REPLACEMENT AND REPAIR**

The parts listed in Figure 5 are customer-replaceable. A complete inventory can be stocked and controlled to prevent lost time when replacement of parts is necessary. Order replacement parts through your representative, or call 1-800-526-5142, or send a facsimile of your purchase order to 1-717-986-7605, or write to:

CUSTOMER SERVICE (38-35)  
TYCO ELECTRONICS CORPORATION  
P.O. BOX 3608  
HARRISBURG, PA 17105-3608

Tools may also be returned for evaluation and repair. For tool repair service, contact a representative at 1-800-526-5136.

**7. REVISION SUMMARY**

Per EC 0990-0198-00:

- Changed tool repair service information in Section 6, REPLACEMENT AND REPAIR
- Updated document format

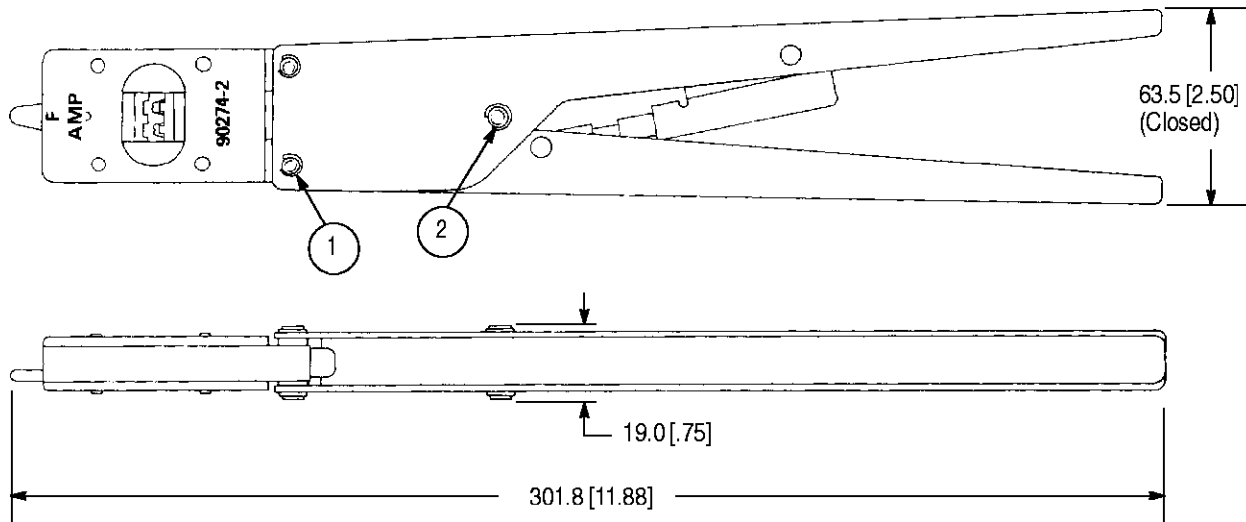

**WEIGHT:** 567 g [1 lb 4 oz.]

**CAUTION**

*Do not remove the retaining pins or permanent damage to the tool may result.*

**REPLACEMENT PARTS**

ITEM	PART NUMBER	DESCRIPTION	QTY PER TOOL
1	21045-3	Ring, Retaining	4
2	21045-9	Ring, Retaining	2

Figure 5