

### PROPER USE GUIDELINES

Cumulative Trauma Disorders can result from the prolonged use of manually powered hand tools. Hand tools are intended for occasional use and low volume applications. A wide selection of powered application equipment for extended-use, production operations is available.

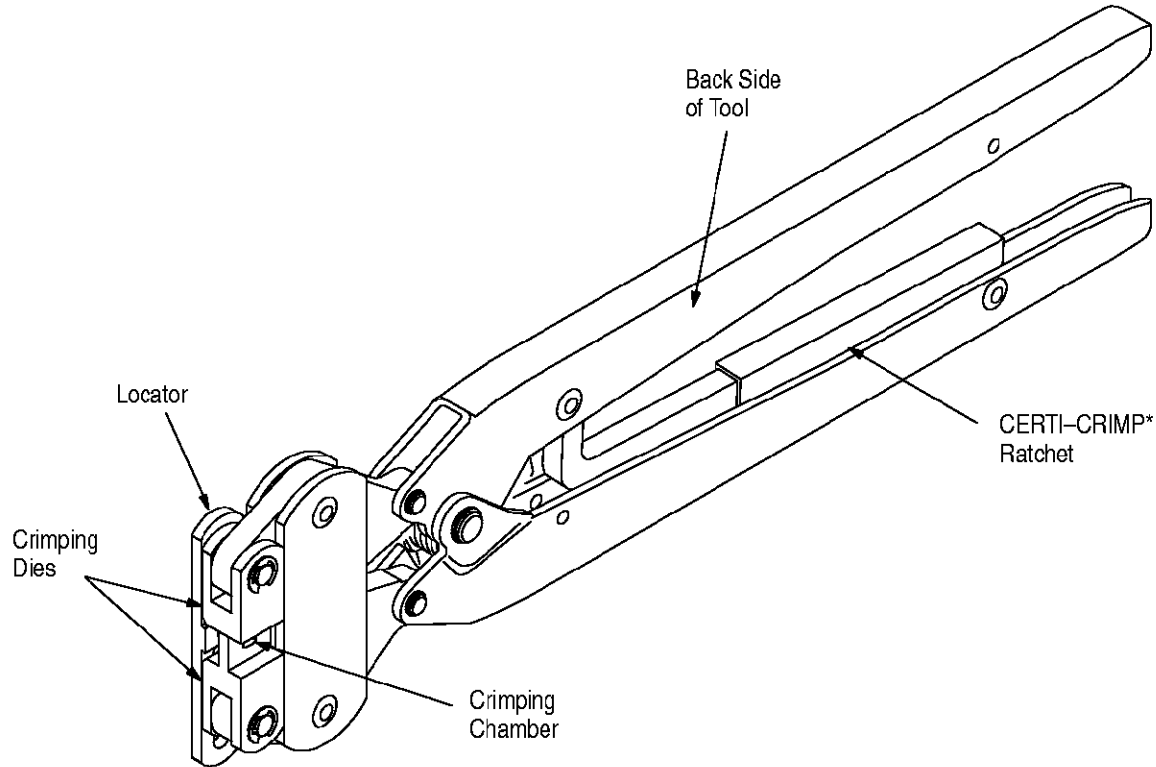

Figure 1

### 1. INTRODUCTION

AMP\* Hand Crimping Tool 90121 is designed to crimp Type I Pin and Socket Power Contacts onto wire sizes No. 18–12 AWG. Catalog 82003 provides a guide for wire-to-contact selection. Read these instructions thoroughly before using the hand tool.

#### NOTE

All dimensions on this document are in metric units [with U.S. customary units in brackets]. Figures and illustrations are for identification only and are not drawn to scale.

Reasons for reissue are provided in Section 6, REVISION SUMMARY.

### 2. DESCRIPTION

The hand tool features two crimping dies, a locator, and a CERTI-CRIMP ratchet. When closed, the dies form the crimping chamber. The locator is used to position the contact in the crimping chamber. The tool number is marked on the BACK side of the tool. See Figure 1.

The CERTI-CRIMP ratchet ensures full crimping of the contact. Once engaged, the ratchet will not release until the tool handles have been fully closed.

### 3. CRIMPING PROCEDURE

Select the appropriate wire size and contact for the hand tool. The wire size and insulation diameter must be within the specified range for the contact. Strip the wire to the length indicated in Figure 2. Do NOT nick or cut the wire strands.

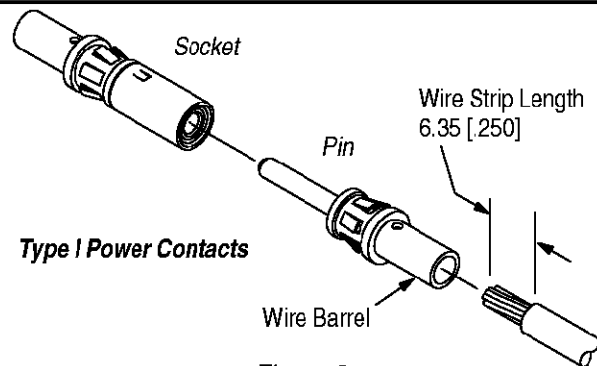

Figure 2

Proceed as follows:

1. Hold the tool so that the back side is facing you.
2. Open the crimping dies by squeezing the tool handles together until the CERTI-CRIMP ratchet releases.
3. Insert the contact through the hole in the locator until the shoulder on the contact butts against the locator. See Figure 3.

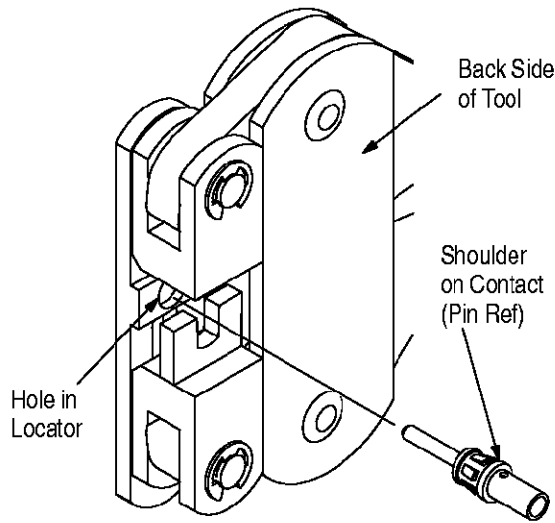

Figure 3

4. Holding the contact in place, squeeze the tool handles together just enough to hold the contact in the crimping chamber. Do NOT deform the wire barrel.
5. Insert stripped wire into the contact wire barrel until the insulation on the wire butts against the wire barrel. See Figure 4.

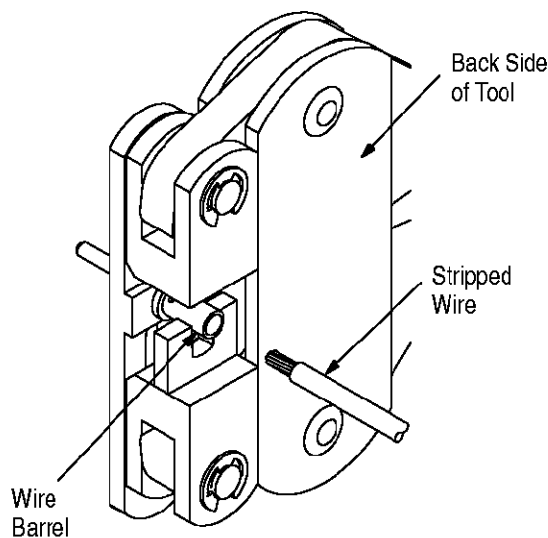

Figure 4

6. Holding wire in place, squeeze tool handles together until CERTI-CRIMP ratchet releases.
7. Allow the tool handles to open fully and remove the crimped contact from the tool. Check to be sure the contact is properly crimped – the wire must be visible through the inspection hole. See Figure 5.

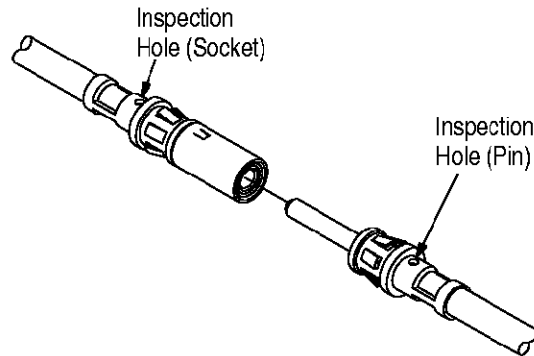

Figure 5

## 4. MAINTENANCE/INSPECTION

### 4.1. Daily Maintenance

Remove all foreign particles with a clean, soft brush or a clean, soft, lint-free cloth. Make sure the proper retaining pins are in place and are secured with the proper retaining rings. If foreign matter cannot be removed easily, or if the proper replacement parts are not available, return the tool to your supervisor.

Make sure all pivot points and bearing surfaces are protected with a thin coat of any good SAE 20 motor oil. Do NOT oil excessively. When the tool is not in use, keep the handles closed to prevent objects from becoming lodged between the dies, and store the tool in a clean, dry area.

### 4.2. Periodic Inspection

Regular inspections should be performed by quality control personnel. A record of scheduled inspections should remain with the tool and/or be supplied to the supervisory personnel responsible for the tool. Though recommendations call for at least one inspection a month, the inspection frequency should be based on the amount of use, ambient working conditions, operator training and skill, and established company standards. These inspections should be performed in the following sequence:

#### A. Visual Inspection

1. Remove all lubrication and accumulated film by immersing the tool (handles partially closed) into a suitable degreaser that will not affect paint or plastic material.
2. Make certain all retaining pins are in place and are secured with the proper retaining rings. If replacements are necessary, refer to Figure 7.

3. Close the tool handles until the ratchet releases, and then allow the handles to open freely. If they do not open quickly and fully, then the spring is defective and must be replaced, refer to Figure 7.

4. Inspect the head assembly, with special emphasis on checking for worn, cracked, or broken crimping dies. If damage to any part of the head is evident, return the tool for evaluation and repair (see Section 5, REPLACEMENT AND REPAIR).

**B. Gaging the Crimping Chamber**

This inspection requires the use of a plug gage conforming to the diameters in Figure 6. To gage the crimping chamber, proceed as follows:

1. Remove traces of oil or dirt from the crimping chamber and the plug gage.
2. Close the tool handles until the dies have bottomed and hold in this position. Do not force the dies beyond initial contact.
3. Carefully insert the GO element into the crimping chamber; do not force it. The GO element must pass completely through the crimping chamber. See Figure 6.
4. In the same manner, try to insert the NO-GO element into the same crimping chamber. The NO-GO element may begin entry, but may not pass through the crimping chamber. See Figure 6.

**Suggested Plug Gage Design**

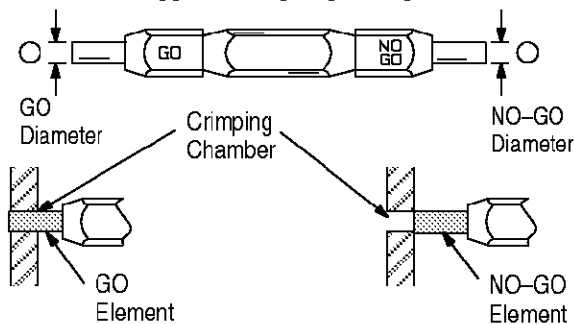

WIRE SIZE (AWG) (Max.)	GAGE ELEMENT DIAMETER	
	GO	NO-GO
12	2.1209 - 2.1285 [.0835 - .0838]	2.2453 - 2.2479 [.0884 - .0885]

Figure 6

If the crimping chamber conforms to the gage inspection, the tool is considered dimensionally correct, and should be lubricated with a THIN coat of any good SAE 20 motor oil. If not, refer to Section 5, REPLACEMENT AND REPAIR.

For additional information concerning the use of the plug gage, refer to Instruction Sheet 408-7424.

**C. CERTI-CRIMP Ratchet Inspection**

Obtain a 0.025 [.001] shim that is suitable for checking the clearance between the bottoming surfaces of the crimping jaws. Proceed as follows:

1. Select a contact and *maximum* size wire for the hand tool.
2. Position the contact and wire between the crimping dies, as described in Section 3, CRIMPING PROCEDURE.
3. Holding the wire in place, squeeze the tool handles together until the CERTI-CRIMP ratchet releases. Hold the handles in this position, maintaining just enough tension to keep the dies closed.
4. Check the clearance between the bottoming surfaces of the crimping dies. If the clearance is 0.025 [.001] or less, the ratchet is satisfactory. If the clearance exceeds 0.025 [.001], the ratchet is out of adjustment and must be repaired.

**5. REPLACEMENT AND REPAIR**

The parts listed in Figure 7 are customer-replaceable. A complete inventory can be stocked and controlled to prevent lost time when replacement of parts is necessary. Order replacement parts through your representative, or call 1-800-526-5142, or send a facsimile of your purchase order to 1-717-986-7605, or write to:

CUSTOMER SERVICE (38-35)  
 TYCO ELECTRONICS CORPORATION  
 P.O. BOX 3608  
 HARRISBURG, PA 17105-3608

Tools may also be returned for evaluation and repair. For tool repair service, contact a representative at 1-800-526-5136.

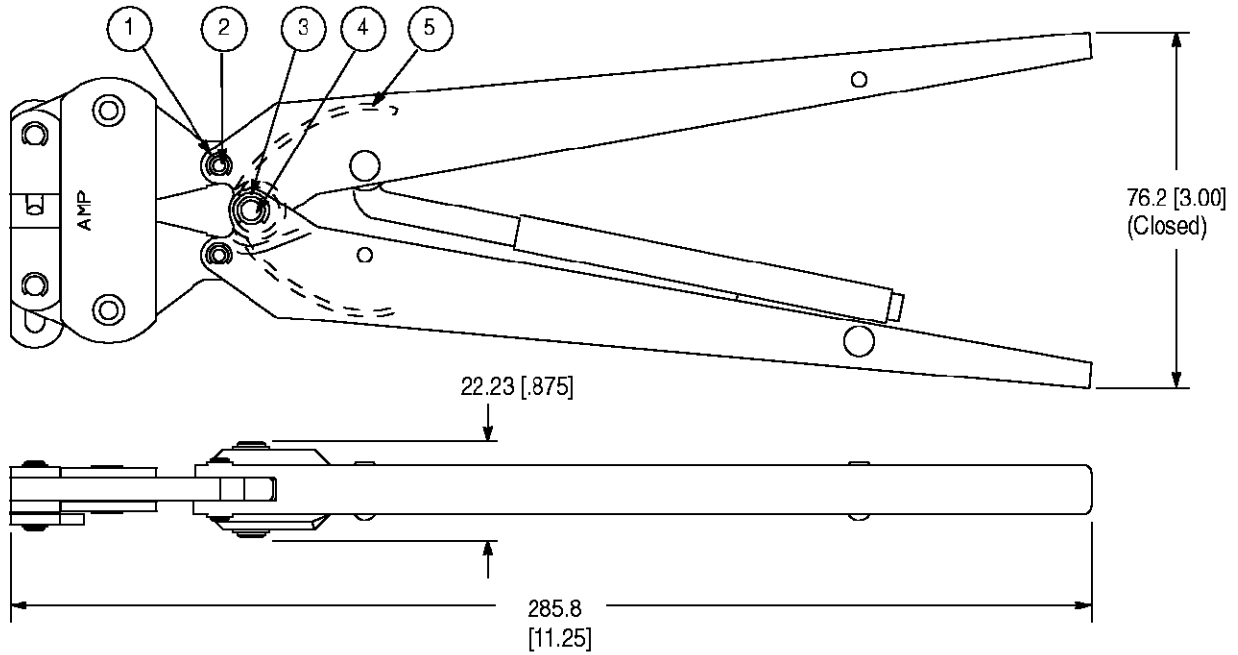

Weight: 539 g [1 lb 3 oz.]

REPLACEMENT PARTS			
ITEM	PART NUMBER	DESCRIPTION	QTY PER TOOL
1	21045-3	Ring, Retaining	4
2	8-59558-2	Pin, Retaining	2
3	21045-6	Ring, Retaining	2
4	2-23620-9	Pin, Retaining	1
5	39364	Spring, Handle	1

Figure 7

**6. REVISION SUMMARY**

Per EC 0990-0761-99:

- Changed tool repair service information in Section 5, REPLACEMENT AND REPAIR
- Updated document format