

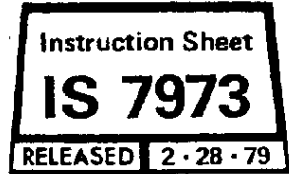

APPLICATION AND MAINTENANCE
FOR AMP* HAND CRIMPING TOOL 90313-2



Section I of this instruction sheet provides application procedures for AMP hand crimping tools.

Section II provides maintenance and inspection procedures for AMP hand crimping tools.

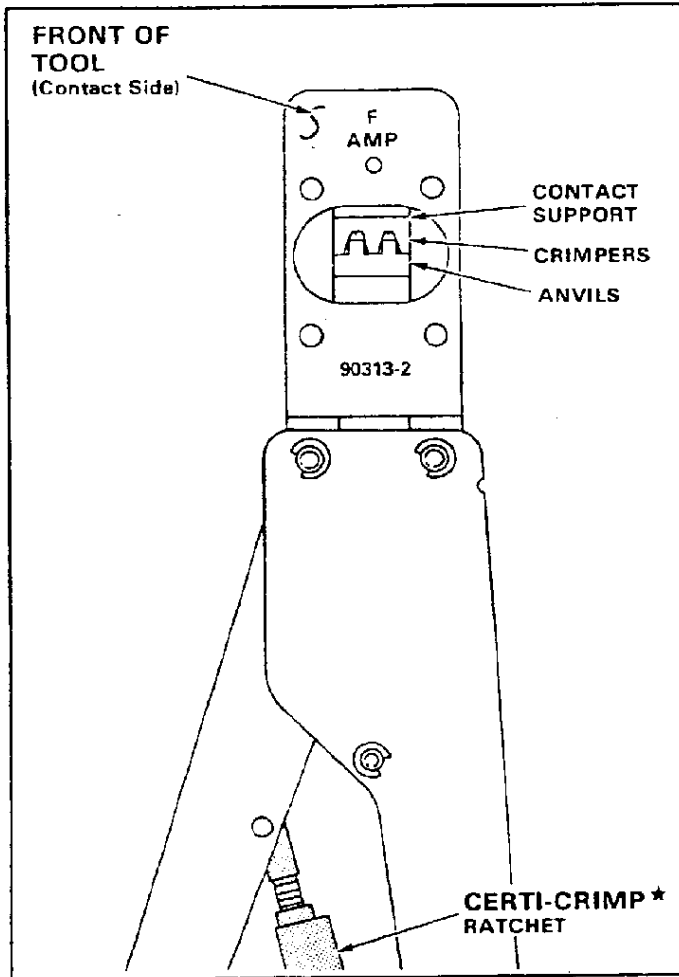

Fig. 1-1

SECTION I APPLICATION

I-1. INTRODUCTION

AMP Hand Crimping Tool 90313-2 is designed to crimp the AMP FFC round wire loose piece (LP) pin and receptacle contacts listed in Figure I-2. Read these instructions thoroughly before starting.

NOTE All dimensions presented on this instruction sheet are in inches, unless otherwise stated.

I-2. DESCRIPTION (Figures I-1 and I-3)

The FRONT OF TOOL (contact side), into which the contact is inserted, has the tool number marked on it. The BACK OF TOOL (wire side), into which the wire is inserted, has the wire size marked above the crimp section.

*TRADEMARK OF AMP INCORPORATED

This tool features two fixed dies (crimpers), two movable dies (anvils), a contact support, a contact locator, a wire stop, an ejector, and a CERTI-CRIMP ratchet.

The contact support prevents the contact from bending during the crimping procedure.

The contact locator positions the contact between the crimping dies. In use, it rests in the locator slot. See Figure I-2.

The wire stop aids in locating the wire in the contact.

The ejector pulls the locator down and ejects the crimped contact when the tool handles are FULLY opened.

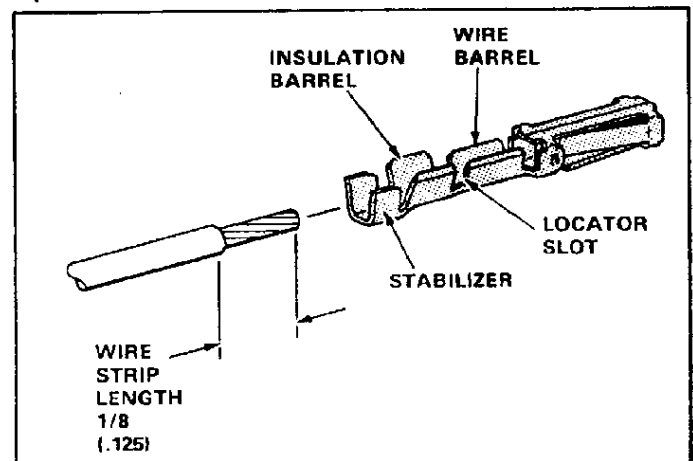

WIRE		CONTACT			CRIMP SECT (Wire Size Marking)
SIZE (AWG)	INSUL DIA	TYPE	LP	STRIP	
32 to 28	.025 to .048	Pin	88048-3, -5, 1-88048-0, & 1-88048-3	88048-2, -4, -6, -7, -8, -9, 1-88048-1, & 1-88048-2	28-32
		Rcpt	88017-6, -7, -8, & 1-88017-7	88017-2, -3, -4, 1-88017-0, 1-88017-1, 1-88017-2, 1-88017-5, & 1-88017-6	
26	.025 to .048	Pin	88048-3, -5, 1-88048-0, 1-88048-3	88048-2, -4, -6, -7, -8, -9, 1-88048-1, & 1-88048-2	26
		Rcpt	88017-6, -7, -8, & 1-88017-7	88017-2, -3, -4, 1-88017-0, 1-88017-1, 1-88017-2, 1-88017-5, & 1-88017-6	

Fig. I-2

Copyright 1979 by AMP Incorporated, Harrisburg, Pa. All International Rights Reserved. AMP Incorporated products covered by U.S. and Foreign Patents and/or Patents Pending.

The CERTI-CRIMP ratchet assures full crimping of the contact. Once engaged, the ratchet will not release until the tool handles have been FULLY closed.

CAUTION

The crimping dies bottom before the CERTI-CRIMP ratchet releases. This is a design feature that assures maximum electrical and tensile performance of the crimp. Do NOT re-adjust the ratchet.

I-3. CRIMPING PROCEDURE

Refer to the chart in Figure I-2, and then select wire of the specified size and insulation diameter. Strip the wire to the length indicated — do NOT cut or nick the wire strands.

Select an applicable loose piece contact, and identify the appropriate crimp section (according to the wire size markings on the BACK of the tool).

Proceed as follows:

1. Hold the tool so the BACK (wire side) is facing you. See Figure I-3.
2. Make sure the ratchet is released by squeezing the tool handles and allowing them to open FULLY.
3. Looking straight into the BACK of the appropriate crimp section, insert the contact (stabilizer first) into the FRONT of the crimp section. Position the contact in the crimpers so that the locator enters the locator slot between the insulation and wire barrels (see Figure I-3). Push the contact in until the wire barrel butts against the contact locator.

4. Hold the contact in this position and squeeze the tool handles until the insulation anvil starts entry into the insulation crimper. Do NOT deform the insulation barrel or wire barrel.

5. Insert a properly stripped wire through the wire slot in the locator and into the wire barrel of the contact until the wire butts against the wire stop. See Figure I-3.

6. Hold the wire in place and squeeze the tool handles until the ratchet releases.

7. Allow the tool handles to open FULLY so the ejector can push the contact out of the crimpers. Remove the crimped contact from the tool.

I-4. DAILY MAINTENANCE

Remove all foreign particles with a clean, soft brush, or a clean, soft, lint-free cloth. Make sure the proper retaining pins are in place, and secured with the proper retaining rings. If foreign matter cannot be removed easily, or if the proper replacement parts are not available, return the tool to your supervisor.

Make certain all pivot points and bearing surfaces are protected with a THIN coat of any good SAE No. 2 motor oil. Do NOT oil excessively. When the tool is not in use, keep the handles closed to prevent objects from becoming lodged between the crimping dies and store the tool in a clean, dry area.

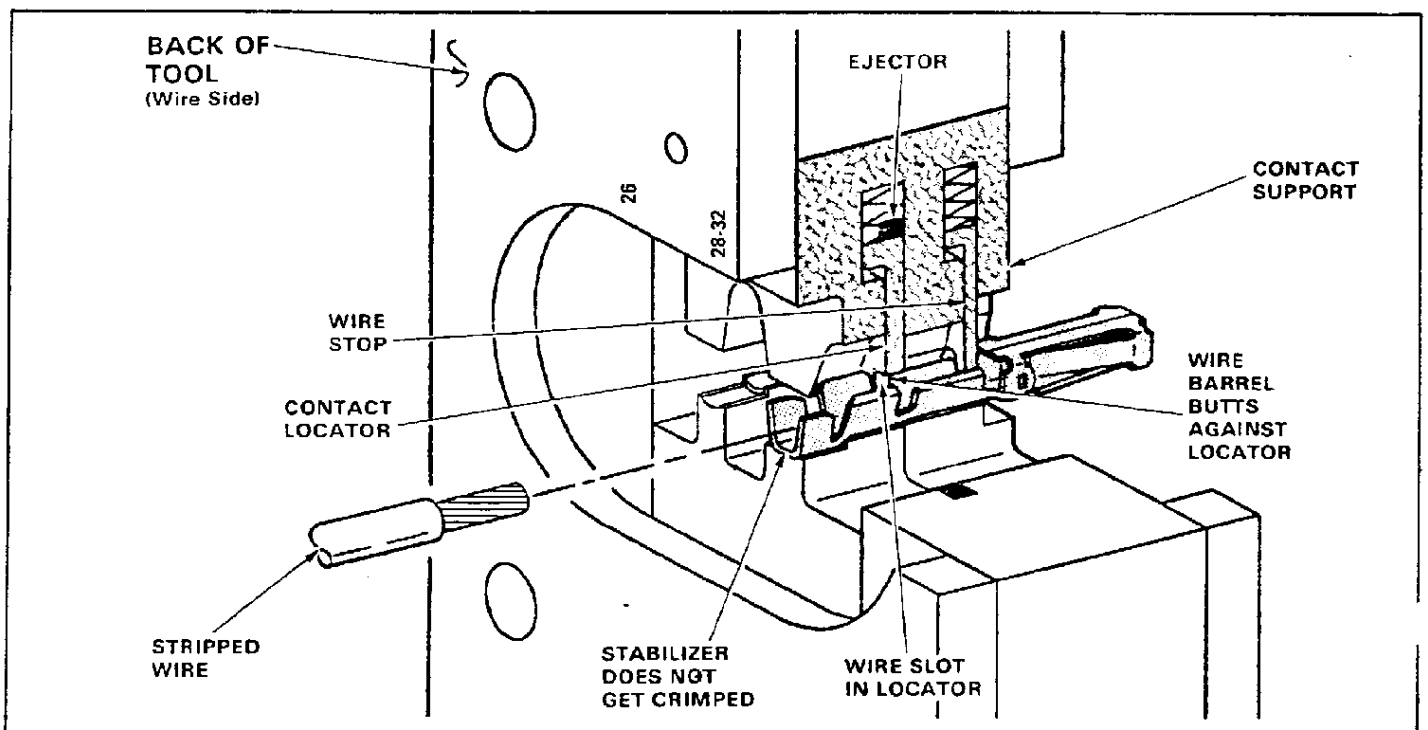
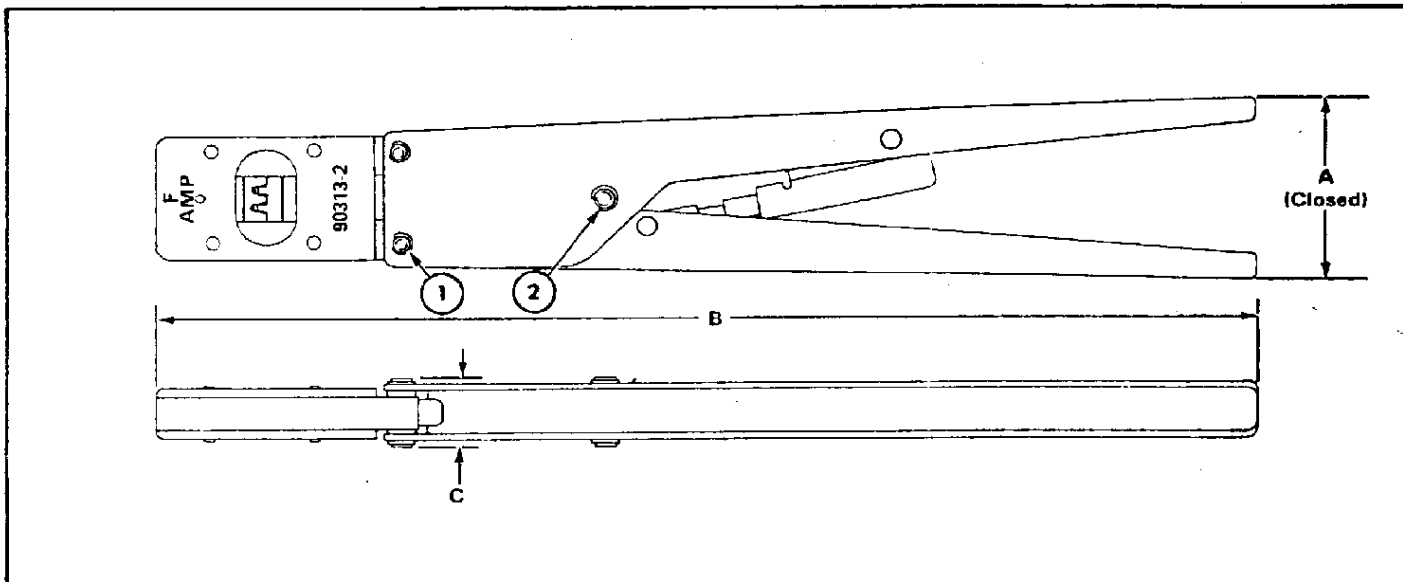

Fig. I-3

Section I of this instruction sheet provides application procedures for AMP hand crimping tools.

Section II provides maintenance and inspection procedures for AMP hand crimping tools.



TOOL SPECIFICATIONS		REPLACEMENT PARTS KIT 125218-8			
DIMENSION	WEIGHT	ITEM	PART NUMBER	DESCRIPTION	QTY PER KIT
A	2 1/2	1	21045-3	RING, Retaining	120 to 130
B	11 3/8				
C	3/4				
Engineering Approval		CAUTION: DO NOT REMOVE THE RETAINING PINS AS PERMANENT DAMAGE TO THE TOOL MAY RESULT (see Paragraph II-3).			
Date					
D. D. D. 2/28/79					

Fig. II-1

SECTION II MAINTENANCE/INSPECTION

II-1. TOOL CERTIFICATION

These instructions have been approved by AMP Design, Production, and Quality Control Engineers to provide documented maintenance and inspection procedures in accordance with AMP Corporate Policy No. 3-3. Through AMP test laboratories and the inspection of production assembly, the procedures described herein have been established to ensure quality and reliability of AMP hand crimping tools.

Customer replaceable parts are listed in Figure II-1. A complete inventory should be stocked and controlled to prevent lost time when replacement of parts is necessary. When kit items are needed, order replacement kit part number.

II-2. INSPECTION PROCEDURES

A. Daily Maintenance

It is recommended that each operator of the tool be made aware of — and responsible for — the following four steps of daily maintenance:

1. Remove dust, moisture, and other contaminants with a clean brush, or a soft, lint-free

cloth. Do NOT use objects that could damage the tool.

2. Make sure the proper retaining pins are in place and secured with the proper retaining rings.
3. Make certain all pins, pivot points, and bearing surfaces are protected with a THIN coat of any good SAE No. 20 motor oil. Do NOT oil excessively.
4. When the tool is not in use, keep the handles closed to prevent objects from becoming lodged in the crimping dies and store the tool in a clean, dry area.

B. Periodic Inspection

Regular inspections should be performed by quality control personnel. A record of scheduled inspections should remain with the tool and/or be supplied to supervisory personnel responsible for the tool. Though recommendations call for at least one inspection a month, the inspection frequency should be based on the amount of use, ambient working conditions, operator training and skill, and established company standards. These inspections should be performed in the following sequence:

B-1. Visual Inspection

1. Remove all lubrication and accumulated film by immersing the tool (handles partially closed) in a suitable commercial degreaser that will not affect paint or plastic material.
2. Make certain all retaining pins are in place and secured with retaining rings. If replacements are necessary, refer to parts listed in Figure II-1.
3. Close the tool handles until the ratchet releases, then allow handles to open freely. If they do not open quickly and fully, the spring is defective and must be replaced (see Paragraph II-3, REPAIR).
4. Inspect the head assembly, with special emphasis on checking for worn, cracked, or broken dies. If damage to any part of the head assembly is evident, return the tool to AMP for evaluation and repair (see Paragraph II-3, REPAIR).

B-2. Crimp Height Inspection

This inspection requires the use of a micrometer with a modified anvil as shown in Figure II-2. We recommend the modified micrometer (Crimp Height Comparator RS-1019-5L) which can be purchased from:

York Machinery & Supply Co. VALCO
 20 North Penn St. or 1410 Stonewood Dr.
 York, PA 17401 Bethlehem, PA 18017

Proceed as follows:

1. Refer to the chart in Figure II-2, and select a contact and a wire (maximum size) for each crimp section listed in the chart.
2. Refer to Paragraph I-3, CRIMPING PROCEDURE, and crimp the contact(s) accordingly.
3. Using a crimp height comparator, measure wire barrel crimp height as shown in Figure II-2. If the crimp height conforms to that shown in the chart, the tool is considered dimensionally correct. If not, return the tool to AMP for evaluation and repair (see Paragraph II-3, REPAIR).

For additional information concerning the use of the crimp height comparator, refer to AMP Instruction Sheet IS 7424.

B-3. CERTI-CRIMP Ratchet Inspection

Obtain a .001-in. shim that is suitable for checking the clearance between the bottoming surfaces of the crimping dies.

Proceed as follows:

1. Select a contact and wire (maximum size) for the tool (see Figure II-2).

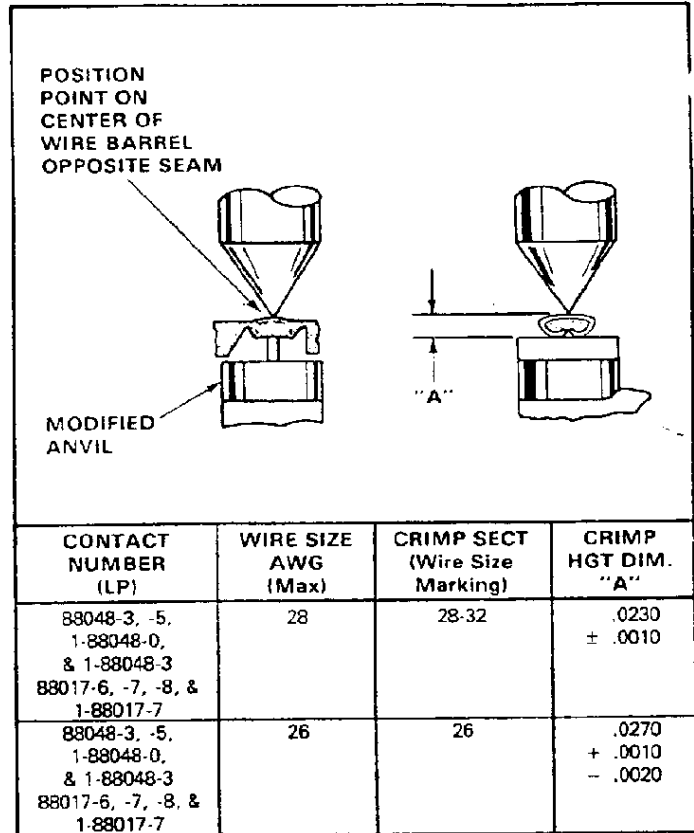

Fig. II-2

2. Position the contact and wire between the crimping dies, according to Paragraph I-3, CRIMPING PROCEDURE (Steps 1 through 5). Holding the wire in place, squeeze the tool handles together until the CERTI-CRIMP ratchet releases. Hold the tool handles in this position, maintaining just enough pressure to keep the dies closed.
3. Check the clearance between the bottoming surfaces of the crimping dies. If the clearance is .001 in. or less, the ratchet is satisfactory. If clearance exceeds .001 in., the ratchet is out of adjustment and must be repaired (see Paragraph II-3, REPAIR).

If the tool conforms to these inspection procedures, lubricate it with a THIN coat of any good SAE No. 20 motor oil and return it to service.

II-3. REPAIR

Parts other than those specified in Figure II-1 must be replaced by AMP to ensure certification of the tool. When repair is necessary, return the tool with a written description of the problem to:

AMP Incorporated
 Customer Repair
 1523 North 4th Street
 Harrisburg, Pennsylvania 17105

or a wholly owned subsidiary of AMP Incorporated.