

PROPER USE GUIDELINES

Cumulative Trauma Disorders can result from the prolonged use of manually powered hand tools. Hand tools are intended for occasional use and low volume applications. A wide selection of powered application equipment for extended-use, production operations is available.

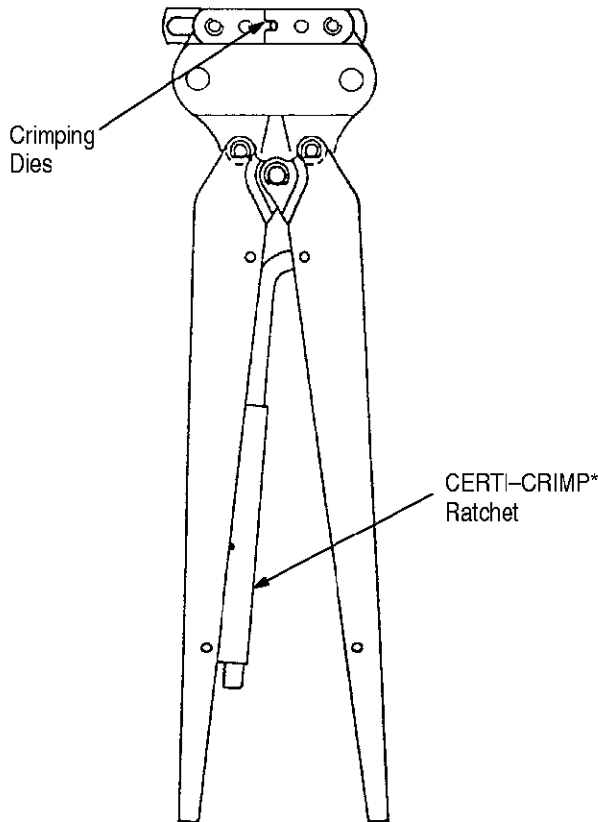

Figure 1

1. INTRODUCTION

AMP Hand Crimping Tools 69156-1 and 69241-1, see Figure 1, are designed to crimp TERMASPLICE* splices on coaxial or shielded cables within a primary insulation diameter range as listed in Figure 2. Splice lead and ground wire sizes 24 through 20 AWG are simultaneously crimped in the splice with the shielded or coaxial cable. Read these instructions thoroughly before using the tools.

Reasons for reissue of this document are provided in Section 6, REVISION SUMMARY.

NOTE *Dimensions on this sheet are in millimeters [with inches in brackets].*

2. DESCRIPTION

The tool (shown in Figure 1) features two sets of crimping dies and a CERTI-CRIMP ratchet.

One die set crimps the cable center conductor and the splice lead conductor in a parallel splice; and the other set crimps the cable braid and ground wire conductor together in a parallel braid splice. Both crimps are simultaneously accomplished with one operating cycle of the tool.

The CERTI-CRIMP ratchet ensures full crimping of the splice. Once engaged, the ratchet will not release until the handles have FULLY closed.

CAUTION *The crimping dies bottom before the CERTI-CRIMP ratchet releases. This design feature ensures maximum electrical and tensile performance of the crimp. Do NOT re-adjust the ratchet.*

3. CRIMPING PROCEDURE

NOTE *Each hand tool is coated with a preservative to prevent rust or corrosion. Wipe this preservative from the tool, particularly from the crimping jaws, before using the tool.*

The crimping procedure requires two separate operations. First, the cable and wires must be prepared and assembled in the splice; then the entire assembly is crimped using the hand tool.

3.1. Cable / Wire Preparation and Assembly

Select the proper cable, splice lead, and ground wire and strip to the dimensions shown in Figure 2. Then refer to Figure 3, and proceed as follows:

1. Slightly twist the cable center conductor strands.
2. Flare the cable braid so that it will easily slide over the support sleeve of the splice.
3. Carefully insert cable into splice so that the center-conductor insulation passes through the support sleeve and the braid passes over and around the support sleeve. Continue to insert cable until the stripped center conductor enters parallel splice area and insulator bottoms in support sleeve.
4. Insert ground wire under side of skirt that has been "stretched" to accommodate the ground wire. Ground wire will then be positioned between the skirt and the braid.

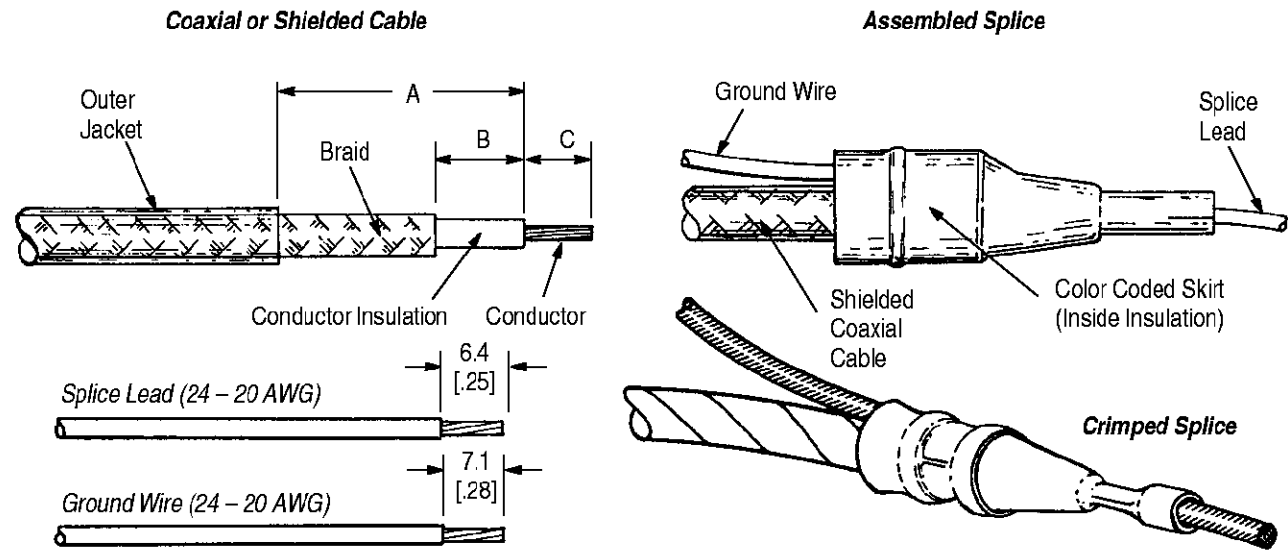

SPLICE NUMBER	STRIP LENGTHS			COLOR CODE	RECOMMENDED COAXIAL CABLE	PRIMARY INSULATION DIA. RANGE	HAND TOOL
	A	B	C				
329413	14.3 [.56]	4.8 [.19]	6.4 [.25]	VIOLET	RG-174-U, RG-187-U	0.84-1.50 [.033-.059]	69241-1
328812		4.0 [.16]	7.1 [.28]	TIN	RG-180-U, RG-195-U	2.16-2.41 [.085-.095]	69156-1

Figure 2

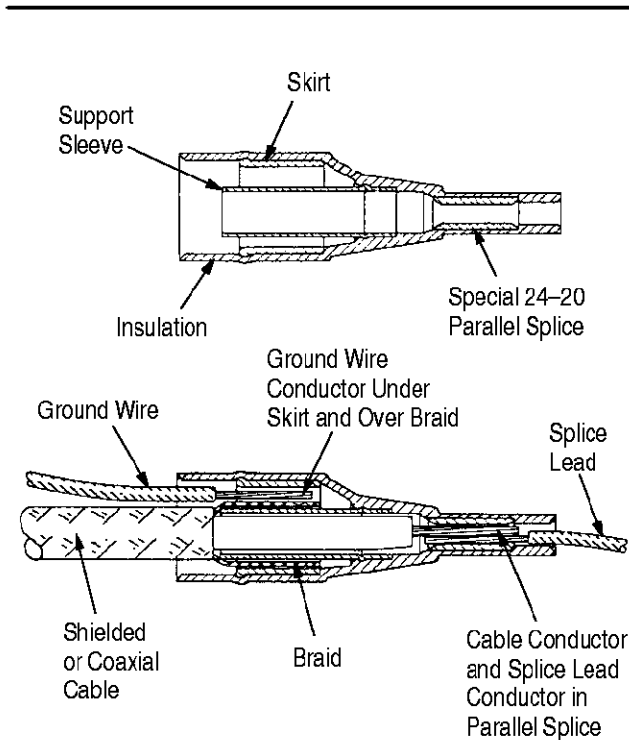

Figure 3

5. While holding ground wire and cable securely in place, insert splice lead into parallel splice area. Make certain that splice lead does not move or bend the cable center conductor. Parallel splice area will accept solid or stranded wire sizes 24 through 20 AWG.

3.2. Crimping the Splice Assembly

To crimp the splice assembly, refer to Figure 4 and proceed as follows:

1. Open the tool's crimping dies by squeezing the handles until the ratchet releases and then allow the handles to open FULLY.
2. Position the splice assembly in the splice and braid crimping dies, as shown in Figure 4. Small shoulder on tapered end of splice should butt against lower splice crimping die.

NOTE Make certain that section of splice containing ground wire faces upper braid die.

3. Slowly squeeze tool handles until splice body is held firmly in place.
4. While holding cable and wires in place, continue to close tool handles until ratchet releases. Allow handles to open FULLY and remove crimped splice.

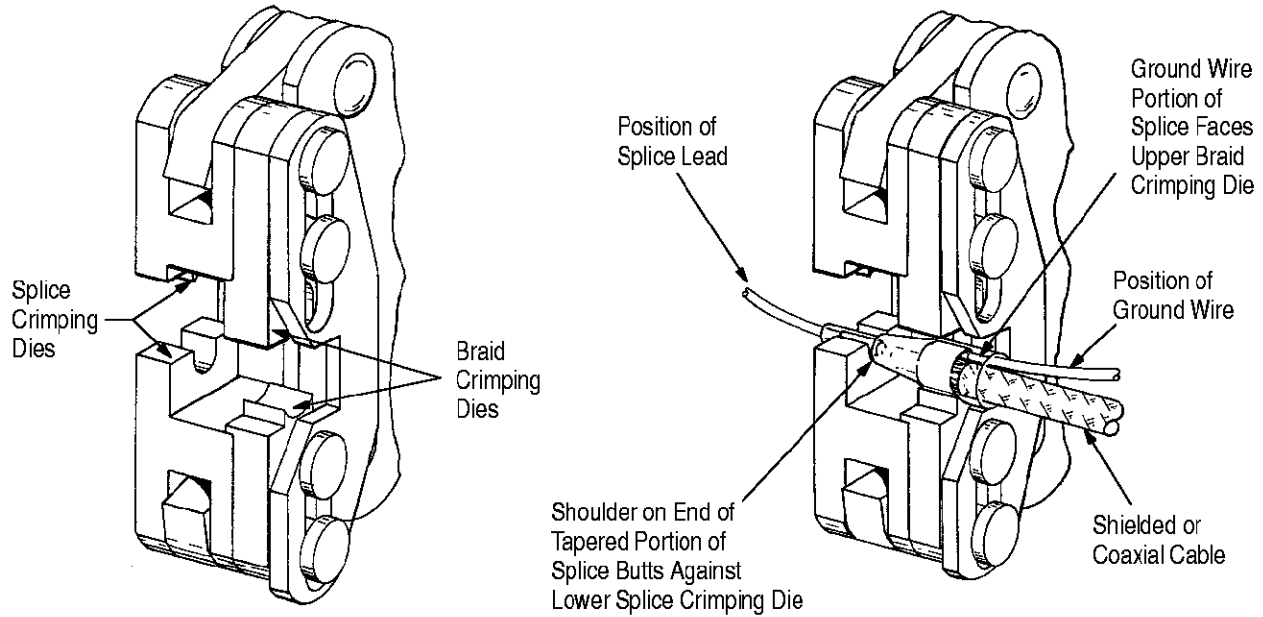

Figure 4

4. MAINTENANCE AND INSPECTION PROCEDURE

Tyco Electronics recommends that a maintenance and inspection program be performed periodically to ensure dependable and uniform terminations.

Frequency of inspection depends on:

1. The care, amount of use, and handling of the hand tool.
2. The presence of abnormal amounts of dust and dirt.
3. The degree of operator skill.
4. Your own established standards.

The hand tool is inspected before being shipped; however, it is recommended that the tool be inspected immediately upon its arrival at your facility to ensure that the tool has not been damaged during shipment. Due to the precision design, it is important that no parts of these tools be interchanged except those replacement parts listed in Figure 7.

4.1. Daily Maintenance

1. Remove dust, moisture, and other contaminants with a clean brush, or a soft, lint-free cloth. Do NOT use objects that could damage the tool.
2. Make certain that the retaining pins are in place and that they are secured with retaining rings.
3. All pins, pivot points, and bearing surfaces should be protected with a thin coat of any good SAE 20 motor oil. Do not oil excessively.

4. When the tool is not in use, keep handles closed to prevent objects from becoming lodged in the crimping dies. Store the tool in a clean, dry area.

4.2. Lubrication

Lubricate all pins, pivot points, and bearing surfaces with SAE 20 motor oil as follows:

- Tools used in daily production – lubricate daily
- Tools used daily (occasional) – lubricate weekly
- Tools used weekly – lubricate monthly

Wipe excess oil from tool, particularly from crimping area. Oil transferred from the crimping area onto certain terminations may affect the electrical characteristics of an application.

4.3. Periodic Inspection

1. Hand tool should be immersed (handles partially closed) in a reliable commercial degreasing compound to remove accumulated dirt, grease, and foreign matter.
2. Close tool handles until ratchet releases and then allow them to open freely. If they do not open quickly and fully, the spring is defective and must be replaced. See Section 5, REPLACEMENT AND REPAIR.
3. Inspect head assembly for worn, cracked, or broken dies. If damage is evident, return the tool for evaluation and repair. See Section 5, REPLACEMENT AND REPAIR.

4.4. Crimping Die Closure Inspection

This inspection requires the use of two plug gages conforming to the dimensions shown in Figure 5. Tyco Electronics does not manufacture or market these gages.

To gage die closure, refer to Figure 6 and proceed as follows:

1. Remove traces of oil or dirt from the crimping chamber and plug gage.
2. Close the tool handles until it is evident that the dies have bottomed; then hold in this position. Do NOT force the dies beyond initial contact.
3. Align the GO element of the proper plug gage with the braid crimp section. Push element straight into the crimp section without using force. The GO element must pass completely through the crimp section.
4. Check the braid crimp section with the NO-GO element in the same manner as step 3. The GO-GO element may start entry, but must not pass completely through the crimp section.

5. Check the splice crimp section by repeating Steps 3 and 4 using the proper plug gage.

If die closures conforms to the gage inspections, the crimp sections are considered dimensionally correct. If correct, the tool should be lubricated with a thin coat of any good SAE 20 motor oil and returned to service. If not correct, the tool must be returned for further evaluation and repair. Refer to Section 5, REPLACEMENT AND REPAIR. For additional information regarding the use of a plug gage, refer to instruction sheet 408-7424.

4.5. CERTI-CRIMP Ratchet Inspection

The CERTI-CRIMP ratchet feature on Tyco Electronics hand tools should be checked to ensure that the ratchet does not release prematurely, allowing the crimping dies to open before they have fully bottomed. Obtain a 0.025-mm [.001-in.] shim that is suitable for checking the clearance between the bottoming surfaces of the crimping dies. Proceed as follows:

1. Select the maximum size cable and corresponding splice from the chart in Figure 2. Then prepare the cable and wires in accordance with Paragraph 3.1, Cable / Wire Preparation and Assembly.

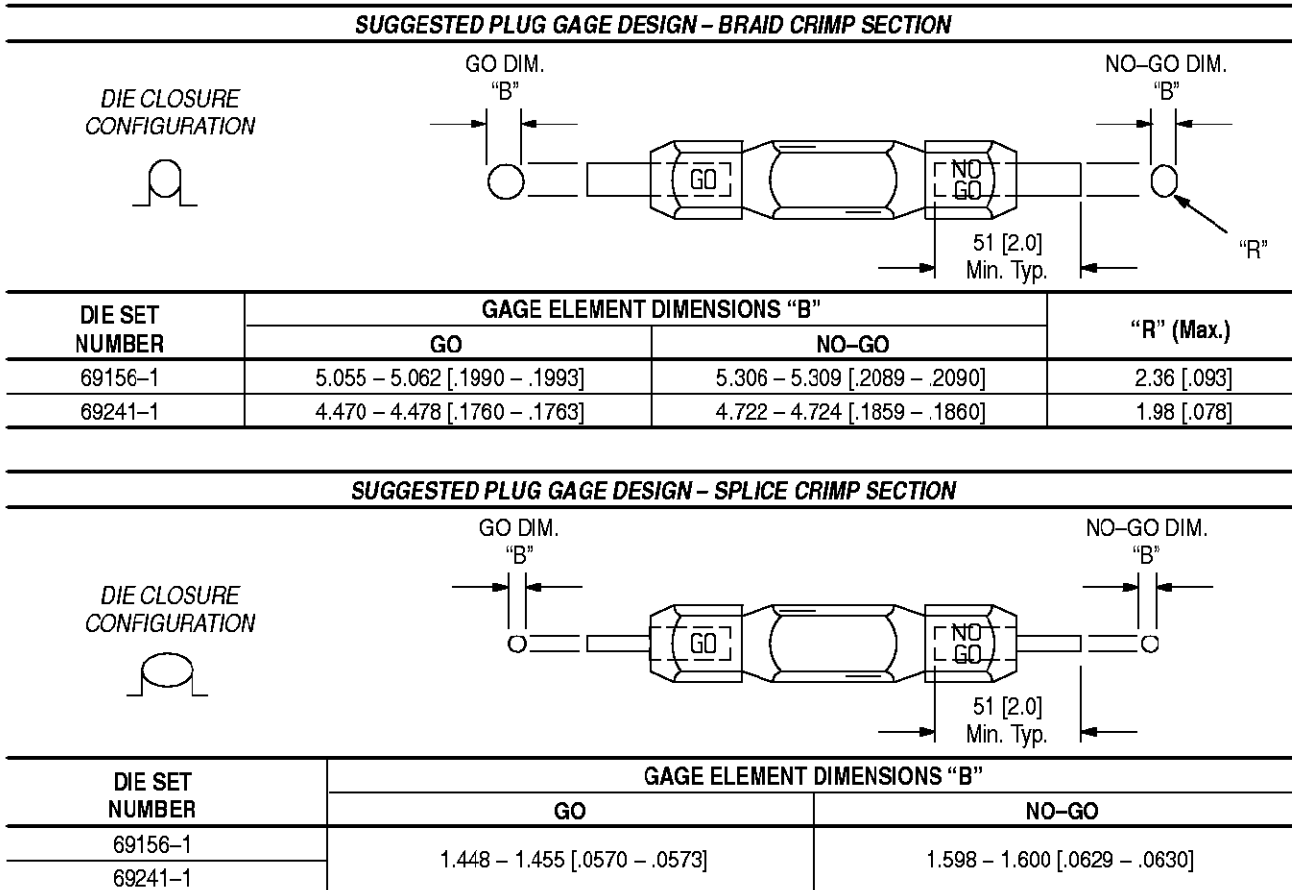
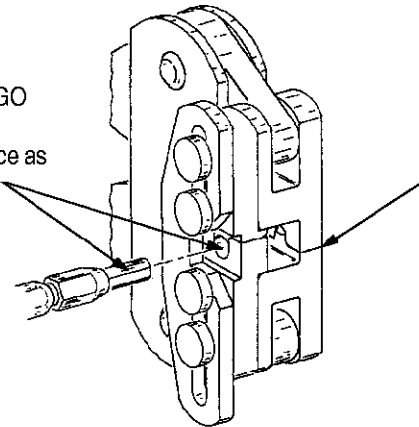

Figure 5

Inspection of Braid Crimp Section

"Flats" on NO-GO Gage Enter Crimping Surface as Shown



Dies Bottomed But Not Under Pressure

Inspection of Splice Crimp Section

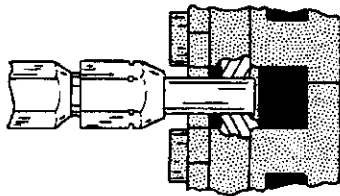
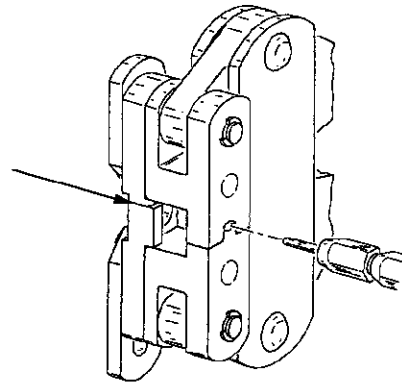

"GO" gage must pass completely through the crimp section.

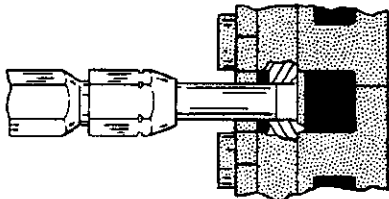
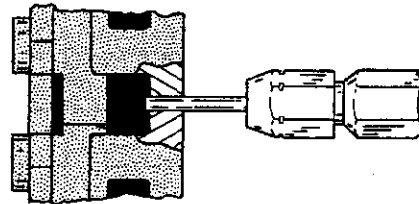

"NO-GO" gage may enter partially, but must not pass completely through the crimp section.

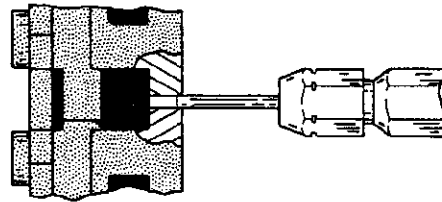

Figure 6

2. Position the splice assembly in the crimping dies, as described in Paragraph 3.2, Crimping the Splice Assembly.

3. Hold the splice assembly in place and squeeze the handles until the CERTI-CRIMP ratchet releases. Hold the handles in this position, maintaining just enough tension to keep the dies closed.

4. Check the clearance between the bottoming surfaces of the crimping dies. If the clearance is 0.025 mm [.001 in.] or less, the ratchet is satisfactory. If clearance exceeds 0.025 mm [.001 in.], the ratchet is out of adjustment and

must be repaired. See Section 5, REPLACEMENT AND REPAIR.

5. REPLACEMENT AND REPAIR

Replacement parts are listed in Figure 7. Parts other than those listed in Figure 7 should be replaced by Tyco Electronics to ensure quality and reliability of the tool. Order replacement parts through your Tyco Electronics representative, or call 1-800-526-5142, or send a facsimile of your purchase order to 1-717-986-7605, or write to:

CUSTOMER SERVICE (38-35)
TYCO ELECTRONICS CORPORATION
P.O. BOX 3608
HARRISBURG, PA 17105-3608

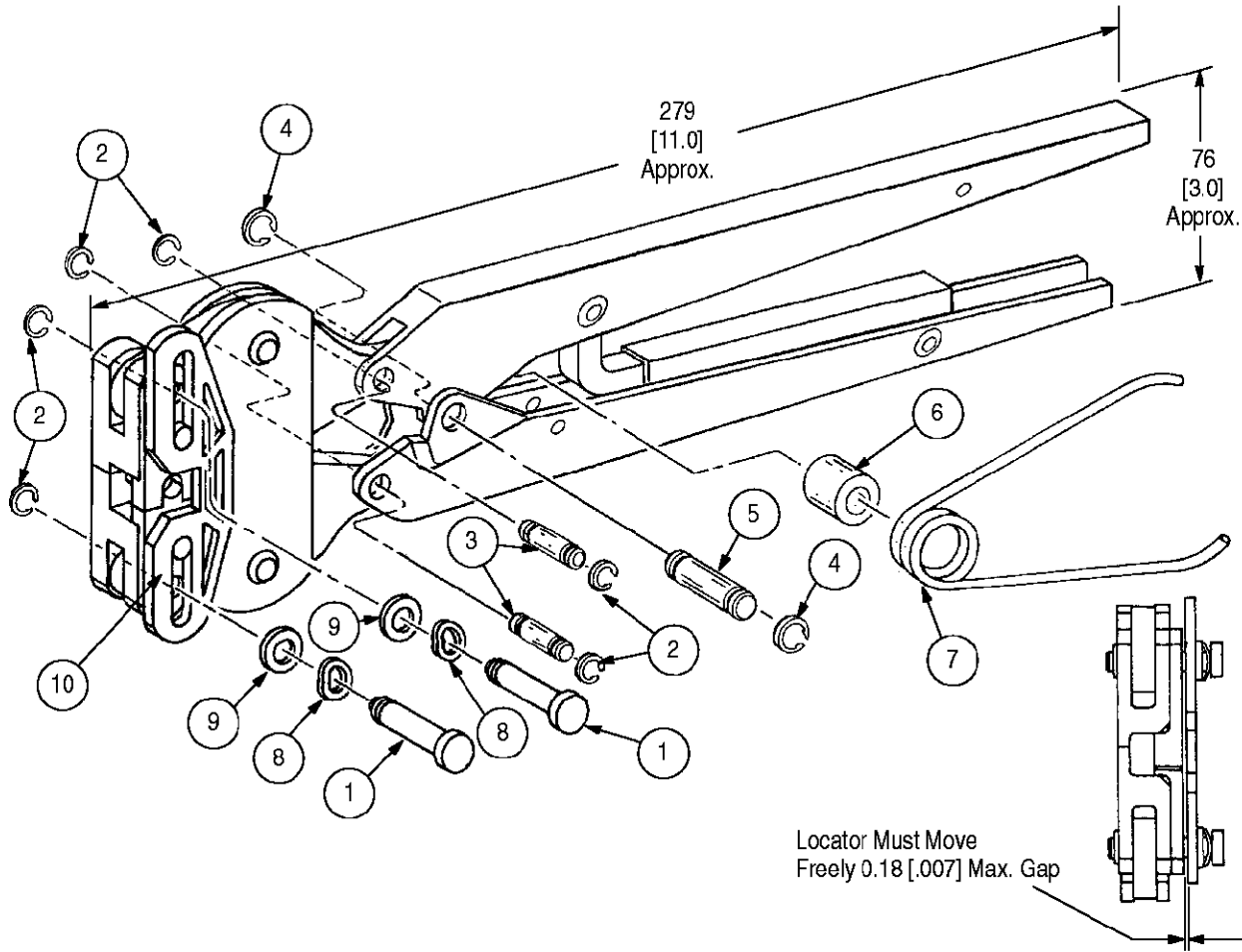

REPLACEMENT PARTS

ITEM	PART NUMBER	DESCRIPTION	QTY PER ASSY
1	1-304197-0	PIN, Retaining	2
2	21045-3	RING, Retaining	6
3	8-59558-2	PIN, Retaining	2
4	21045-6	RING, Retaining	2
5	2-23620-9	PIN, Retaining	1
6	6-59591-7	COLLAR	1
7	39364	SPRING	1
8	24088-8	WASHER, Curved	2
9	125115-1	WASHER	2
10	307089-3	LOCATOR	1

Figure 7

For tool repair service, please contact a Tyco Electronics representative at 1-800-526-5136.

6. REVISION SUMMARY

Since the previous release of this document, the following changes have been made:

Per EC 0990-0262-01

- Updated document to corporate requirements
- Removed obsolete Hand Crimping Tool 69366-1 and all related information associated with the tool
- Removed obsolete Splice 1-329413-0 from Figure 2
- Changed Primary Insulation Dia. range of Splice 328812 in Figure 2 from 2.16-2.67 [.085-.105] to 2.16-2.41 [.085-.095]