

PROPER USE GUIDELINES

Cumulative Trauma Disorders can result from the prolonged use of manually powered hand tools. AMP hand tools are intended for occasional use and low volume applications. AMP offers a wide selection of powered application equipment for extended-use, production operations.

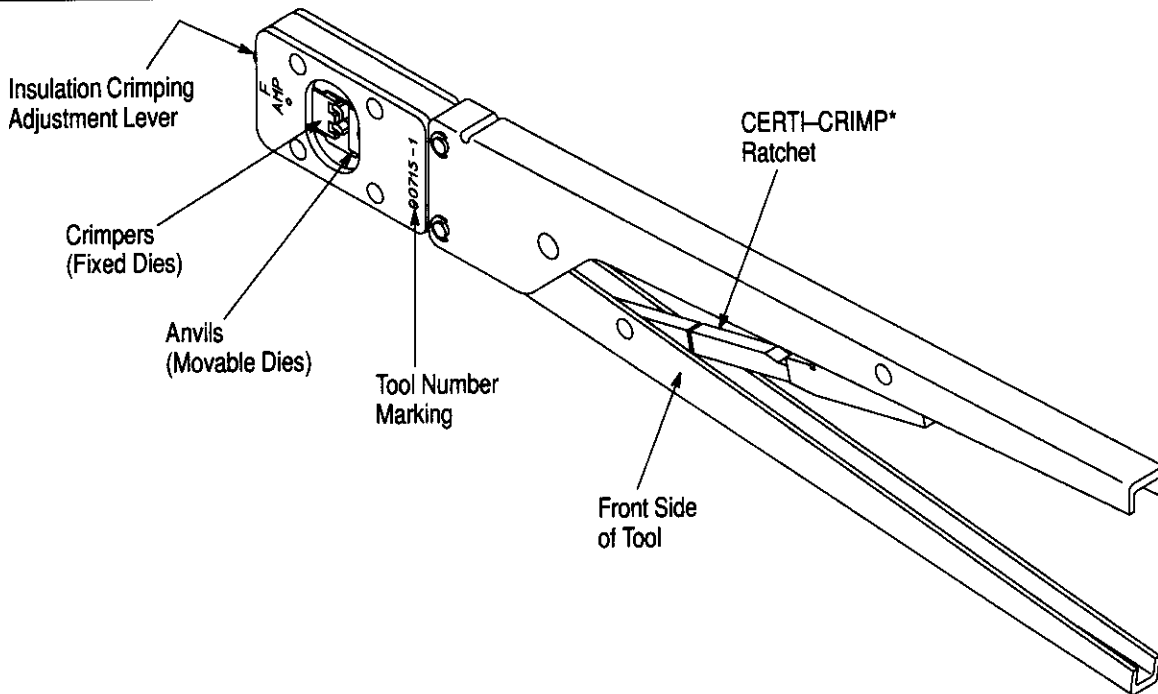

Figure 1

1. INTRODUCTION

AMP* Straight Action Hand Tool 90715-1 is designed to crimp Audio/Microphone Pin Contact 788000-2 onto wire sizes 20-18 AWG with an insulation diameter range of 2.03-2.54 mm [.080-.100 in.]. Read these instructions thoroughly before using the hand tool.

NOTE

Dimensions on this sheet are in millimeters [with inch equivalents provided in brackets]. Figures are for identification only.

2. DESCRIPTION

The hand tool features a head with two crimpers (fixed dies), two anvils (movable dies), an insulation crimping adjustment lever, a contact support, a locator/wire stop, an ejector, and a CERTI-CRIMP ratchet. The FRONT side of the tool, into which the contact is inserted, has the tool number marked on it. The wire is inserted in the BACK side of the tool which is marked above each crimping chamber with the wire size range. See Figure 1.

The insulation crimping adjustment lever is used to regulate the crimp height of the contact insulation

barrel. The contact support prevents the contact from bending during the crimping procedure.

The locator/wire stop positions the contact between the dies and aids in locating the wire in the contact. In use, it rests in the contact locator slot. The ejector pulls the locator down and ejects the crimped contact when the tool handles are fully opened.

The CERTI-CRIMP ratchet ensures full crimping of the contact. Once engaged, the ratchet will not release until the tool handles have been FULLY closed.

CAUTION

The crimping dies bottom before the CERTI-CRIMP ratchet releases. This design feature ensures maximum electrical and tensile performance of the crimp. Do NOT re-adjust the ratchet.

3. CRIMPING PROCEDURE

Select the appropriate wire size and contact for the hand tool. The wire size and insulation diameter must be within the specified range for the contact. Strip the wire to the length indicated in Figure 2. Do NOT nick or cut the wire strands.

1. Hold tool so that the BACK side is facing you.

**Audio/Microphone
Pin Contact**

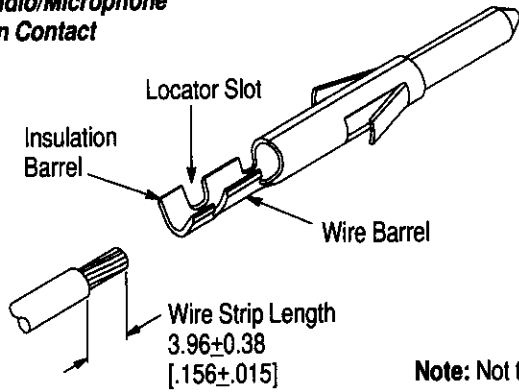

Figure 2

2. Squeeze the tool handles together until the CERTI-CRIMP ratchet releases, and allow the handles to open fully.

3. Insert the contact insulation barrel from the FRONT side of the tool into the appropriate crimping chamber. Position the contact on the crimpers so that the wire stop enters the contact locator slot. Make sure that the contact is flush with the edge of the die. See Figure 3.

4. Holding the contact in place, squeeze the tool handles together just enough to hold the contact in the crimping chamber.

NOTE Do NOT deform the contact insulation barrel or wire barrel.

5. Insert the stripped wire through the wire slot in the locator and into the contact wire barrel. The wire should extend slightly beyond the end of the wire barrel and the wire insulation should butt against the wire stop.

6. Holding the wire in place, squeeze tool handles together until CERTI-CRIMP ratchet releases.

7. Allow tool handles to open FULLY and remove crimped contact from tool.

NOTE For detailed information on inspecting the crimped contact, refer to Application Specification 114-10011.

4. INSULATION CRIMPING ADJUSTMENT

The hand tool has three insulation crimping adjustment positions to adjust the wire insulation grip: 1—Tight, 2—Medium, and 3—Loose. To determine the proper insulation crimp setting, proceed as follows:

1. Slide the insulation crimping adjustment lever to Position 3 (marked on the BACK side of the tool). Refer to Figure 3.
2. Position contact into crimping chamber as described in Section 3, CRIMPING PROCEDURE.
3. Insert an UNSTRIPPED wire into just the insulation barrel. Crimp contact and remove from crimping chamber.

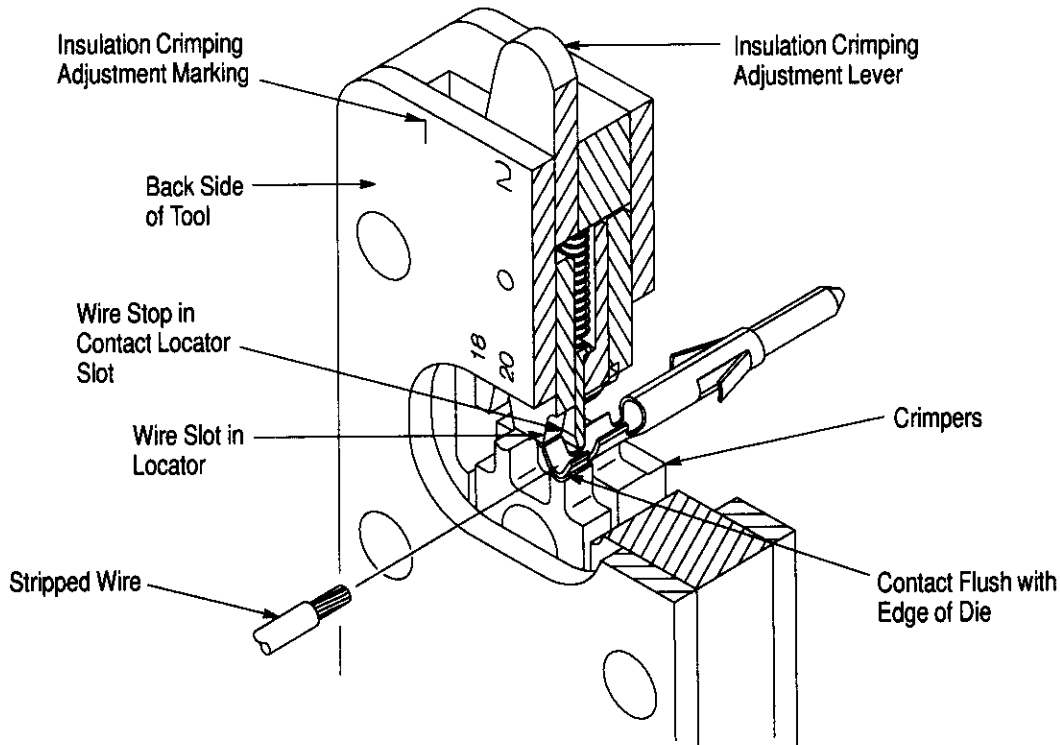

Figure 3

4. Check the insulation support by bending the wire back and forth once. The insulation barrel should retain grip on the wire insulation. If the wire pulls out, move the insulation crimping adjustment lever to the next tighter position and perform another test crimp. If the wire does not pull out, the lever is properly adjusted and the hand tool is ready for crimping.

NOTE *Adjust the lever, as necessary, until the desired insulation grip is obtained. Crimp should hold wire insulation firmly without cutting into it. Do NOT use a tighter grip than necessary.*

5. MAINTENANCE AND INSPECTION

AMP recommends that a maintenance and inspection program be performed periodically to ensure dependable and uniform terminations. Though recommendations call for at least one inspection a month, frequency of inspection depends on:

1. The care, amount of use, and handling of the hand tool.
2. The presence of abnormal amounts of dust and dirt.
3. The degree of operator skill.
4. Your own established standards.

The hand tool is inspected before being shipped; however, AMP recommends that the tool be inspected immediately upon arrival at your facility to ensure that the tool has not been damaged during shipment.

5.1. Daily Maintenance

1. Hand tool should be immersed (handles partially closed) in a reliable commercial degreasing compound to remove accumulated dirt, grease, and foreign matter. When degreasing compound is not available, tool may be wiped clean with a soft, lint-free cloth. Do NOT use hard or abrasive objects that could damage the tool.
2. Make certain that the retaining pins are in place and that they are secured with retaining rings.

CAUTION *Do NOT remove retaining pins as permanent damage to the tool may result. See Section 6, REPLACEMENT AND REPAIR.*

3. All pins, pivot points, and bearing surfaces should be protected with a THIN coat of any good SAE 20 motor oil. Do not oil excessively.
4. When the tool is not in use, keep handles closed to prevent objects from becoming lodged in the crimping dies. Store the tool in a clean, dry area.

5.2. Periodic Inspection

A. Lubrication

Lubricate all pins, pivot points, and bearing surfaces with SAE 20 motor oil as follows:

- Tool used in daily production—lubricate daily
- Tool used daily (occasional)—lubricate weekly
- Tool used weekly—lubricate monthly

Wipe excess oil from tool, particularly from crimping area. Oil transferred from the crimping area onto certain terminations may affect the electrical characteristics of an application.

B. Visual Inspection

1. Close tool handles until ratchet releases and then allow them to open freely. If they do not open quickly and fully, the spring is defective and must be replaced. See Section 6, REPLACEMENT AND REPAIR.
2. Inspect the head for worn, cracked, or broken areas. If damage is evident, return the tool to AMP for evaluation and repair. See Section 6, REPLACEMENT AND REPAIR.

C. Crimp Height Inspection

This inspection requires the use of a modified micrometer with a modified anvil, as shown in Figure 4. AMP recommends the Crimp Height Comparator RS-1019-5LP which can be purchased from:

Shearer Industrial Supply Co. VALCO
 20 North Penn Street or 1410 Stonewood Drive
 York, PA 17401-1014 Bethlehem, PA 18017-3527

Proceed as follows:

1. Select a contact and *maximum* size wire for the crimping chamber.
2. Refer to Section 3, CRIMPING PROCEDURE, and crimp contact accordingly.

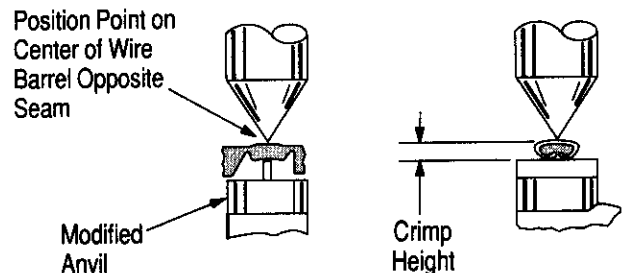

WIRE SIZE AWG (Max)	CRIMP HEIGHT DIMENSION (+0.05 [-0.002])
20	0.86 [.034]
18	1.02 [.040]

Figure 4

3. Using a crimp height comparator, measure the wire barrel crimp height as shown in Figure 4. If the crimp height conforms to that height, the tool is considered dimensionally correct. If not, the tool must be returned to AMP for evaluation and repair. See Section 6, REPLACEMENT AND REPAIR.

4. Check the clearance between the bottoming surfaces of the crimping dies. If the clearance is 0.025 [.001] or less, the ratchet is satisfactory. If clearance exceeds 0.025 [.001], the ratchet is out of adjustment and must be repaired. See Section 6, REPLACEMENT AND REPAIR.

For additional information concerning the use of the crimp height comparator, refer to AMP Instruction Sheet 408-7424.

D. CERTI-CRIMP Ratchet Inspection

The CERTI-CRIMP ratchet feature on AMP hand tools should be checked to ensure that the ratchet does not release prematurely, allowing the dies to open before they have fully bottomed. Obtain a 0.025 [.001] shim that is suitable for checking the clearance between the bottoming surfaces of the crimping dies and proceed as follows:

1. Select a contact and *maximum* size wire for the hand tool.
2. Position the contact and wire between the crimping dies, as described in Section 3, CRIMPING PROCEDURE.
3. Holding the wire in place, squeeze the handles until the CERTI-CRIMP ratchet releases. Hold the handles in this position, maintaining just enough tension to keep the dies closed.

6. REPLACEMENT AND REPAIR

The parts listed in Figure 5 are customer-replaceable. A complete inventory can be stocked and controlled to prevent lost time when replacement of parts is necessary. Order replacement parts through your AMP representative, or call 1-800-526-5142, or send a facsimile of your purchase order to 717-986-7605, or write to:

CUSTOMER SERVICE (38-35)
AMP INCORPORATED
PO BOX 3608
HARRISBURG PA 17105-3608

Parts other than those specified in Figure 5 must be replaced by AMP to ensure quality and reliability of the tool. Tools may be returned to AMP for evaluation and repair. For repairs, send the tool with a written description of the problem to:

CUSTOMER REPAIR (01-12)
AMP INCORPORATED
1523 NORTH 4TH STREET
HARRISBURG PA 17102-1604

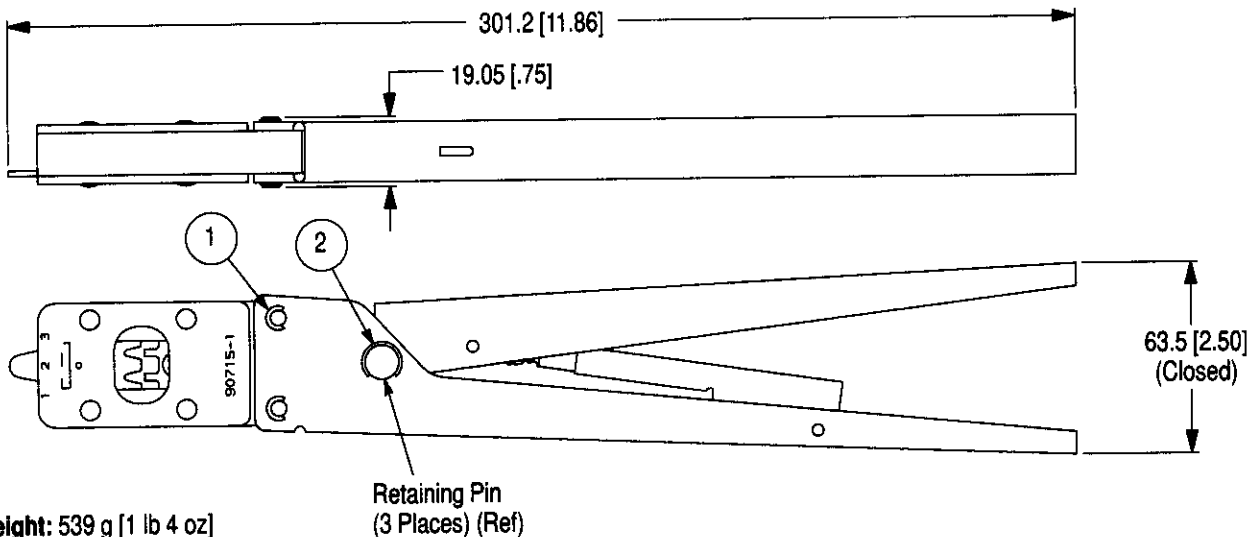

Weight: 539 g [1 lb 4 oz]

REPLACEMENT PARTS

ITEM	PART NUMBER	DESCRIPTION	QTY PER TOOL
1	21045-3	RING, Retaining	4
2	21045-6	RING, Retaining	2

Figure 5