

AMPSEAL Automotive Plug Connector and Header Assembly (Continued)

Contacts

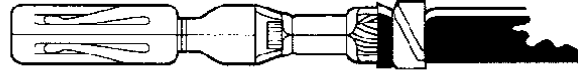
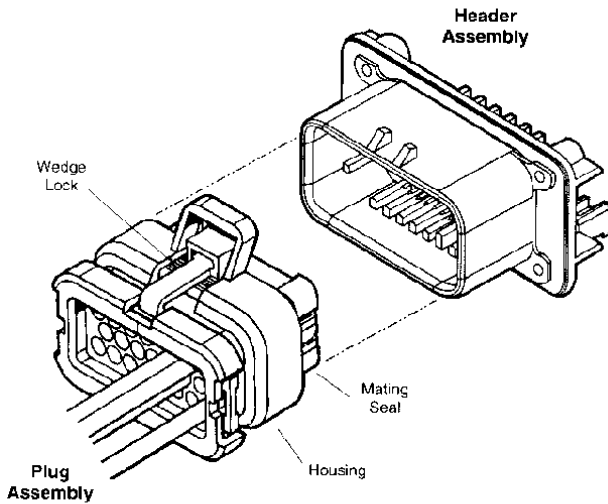

Type	Additional Notes	Part Numbers
Socket Contact	Tin	770520-1
Socket Contact	Gold	770520-3
Socket Contact	Tin, Loose Piece	770854-1
Socket Contact	Gold, Loose Piece	770854-3
Wire Seal Plug		770678-1

Wire		Applicator Part No.**	Hand Tool Part No.
Size (AWG)	Ins. Dia. Range		
20	1.7-2.7 .067-.106	567333-2	58440-1
18	1.7-2.7 .067-.106	567333-2	58440-1
16	1.7-2.7 .067-.106	567333-2	58440-1

**Dash 1 is used in "T" Terminator with automatic equipment. Dash 2 is used in the AMP-O-LECTRIC Model "K" Machine 565435-5.
Refer to Applicator Instruction Sheet AI 8040 for applicator information.

Seal Plug

All circuits are sealed by a diaphragm in the rubber wire seal. During plug connector assembly, the diaphragm is pierced as the contact passes through it. Unused circuit cavities, unless accidentally perforated, will remain sealed. AMPSEAL Automotive Seal Plug **770678-1** is designed to keep out contaminants if diaphragm is pierced.

