

Figure 1

## 1. INTRODUCTION

0.8mm CHAMP Crimper Assemblies 122842-1, 122842-2, and 122842-3 are designed for use in Manual Arbor Frame Assembly 91085-2 (shown in Figure 1) and are used to crimp metal backshell assemblies onto 0.8mm CHAMP connectors. This instruction sheet provides procedures for crimper assembly installation, adjustments, crimping, and maintenance and inspection. Refer to instruction sheet 408-7777 for details concerning the operation and maintenance of the arbor frame assembly.

Read these instructions thoroughly before using the crimper assembly.

### NOTE



All numerical values in this instruction sheet are in metric units [with U.S. customary units in brackets]. Dimensions are in millimeters [and inches]. Figures are not drawn to scale.

Reasons for reissue of this instruction sheet are provided in Section 8, REVISION SUMMARY.

## 2. DESCRIPTION (See Figure 1)

The crimper assembly consists of an upper and lower tooling assembly.

The upper tooling assembly consists of a tool mount and a crimper. The crimper is secured to the tool mount, which is mounted to the ram of the arbor frame assembly with the socket head cap screws supplied with the crimper assembly.

The lower tooling assembly consists of a slide plate, a support block, and a cable clamp spring. The lower tooling assembly mates with the slide base of the arbor frame assembly.

## 3. INSTALLATION OF CRIMPER ASSEMBLY

To install the crimper assembly, refer to Figure 1, and proceed as follows:

### DANGER



The frame assembly must be secured to a work bench to ensure stability during operation.

### 3.1. Lower Tooling Assembly

1. Remove the tool stop from the slide base of the arbor frame assembly.
2. Slide the lower tooling assembly into the tracks of the frame assembly slide base. The cable clamp spring must be oriented to the left side of the slide base as shown in Figure 1.
3. Re-install the tool stop and secure it with the socket head cap screw.

### 3.2. Upper Tooling Assembly

1. Remove the upper tool mount (supplied with the arbor frame assembly) by removing the two flat head cap screws. Do not discard this tool mount.
2. Install the tool mount (supplied with the crimper assembly) to the ram of the arbor frame assembly and secure it with the flat head cap screws.
3. Position the crimper in the tool mount with the longer offset to the right (as shown in Figure 1). Secure crimper to tool mount with the socket head cap screw.

## 4. TOOLING ADJUSTMENTS

The following adjustments are required during the initial setup of the crimper assembly and when changing cable size.

### 4.1. Cable Clamp Springs

The cable clamp springs can be adjusted for various cable diameters by loosening the socket head cap screws and re-positioning the cable clamp springs.

### 4.2. Crimp Height

To check crimp height, a test crimp should be made (refer to Section 5); then, measure the crimp height of the backshell ferrule. Refer to the appropriate application specification (114-series) for the crimp height. If the actual crimp height does not conform to that dimension, proceed as follow:

1. Loosen the setscrew on the adjustment ring. Turn the adjustment ring **CLOCKWISE** to increase crimp height or **COUNTERCLOCKWISE** to decrease crimp height.
2. Re-tighten the setscrew.

## 5. CRIMPING PROCEDURE

Refer to Figure 2 and proceed as follows:

1. Using the ball handle, slide the lower tooling assembly out from under the ram of arbor frame assembly.
2. Position the connector backshell assembly in the support block.

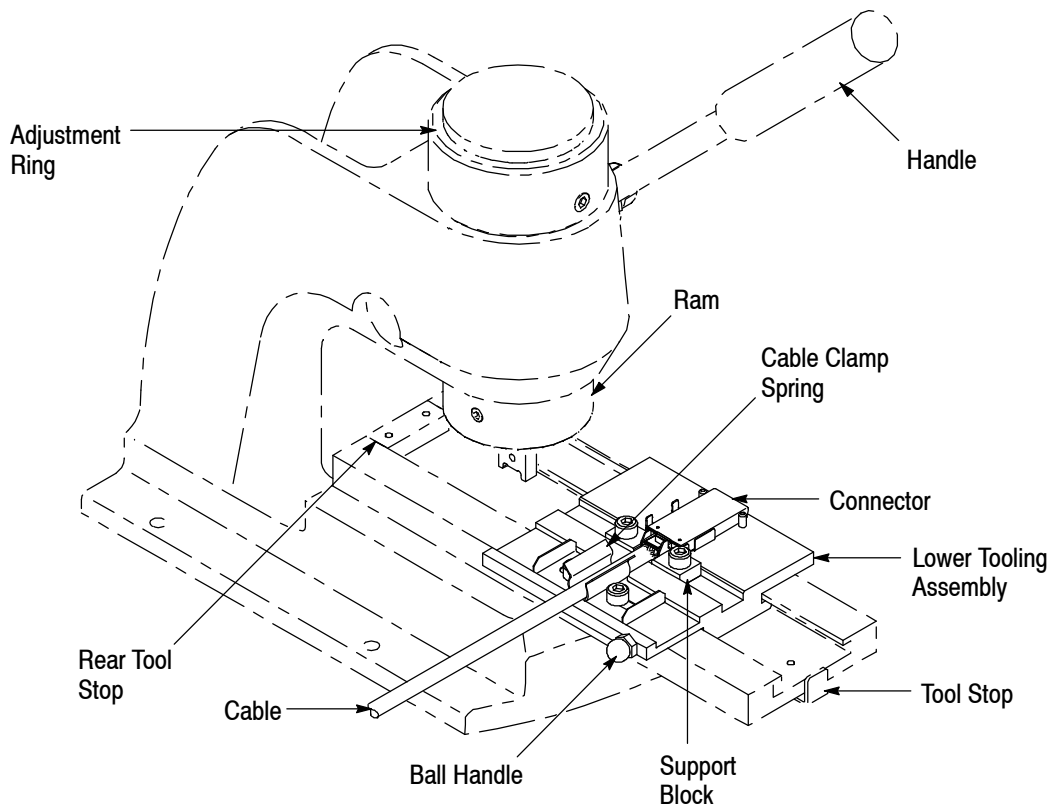

Figure 2

3. Secure the cable in the cable clamp spring.
4. Slide the lower tooling assembly back against the rear tool stop of the arbor frame assembly.
5. To crimp the metal backshell onto the cable, lower the ram using the handle until the adjustment ring is flush with the top of the arbor frame assembly.
6. After the connector is crimped, use the handle to raise the ram; then slide the lower tooling assembly out from under the ram. Remove the connector.

## 6. MAINTENANCE AND INSPECTION

It is recommended that a maintenance and inspection program be performed periodically to ensure dependable and uniform terminations. Frequency of inspection depends on:

1. The care, amount of use, and handling of the crimper assembly.
2. The presence of abnormal amounts of dust and dirt.
3. The degree of operator skill.
4. Your own established standards.

The crimper assembly is inspected before being shipped; however, it is recommended that the assembly be inspected immediately upon its arrival at your facility to ensure that it has not been damaged during shipment. Due to the precision design, it is important that no parts of the crimper assembly be interchanged except the replacement parts listed in Figure 3.

### 6.1. Daily Maintenance

1. Remove dust, moisture, and other contaminants with a clean brush, or a soft, lint-free cloth. DO NOT use objects that could damage the crimper assembly.

2. Make certain that upper and lower subassemblies and cable clamp springs are in place and properly secured.
3. When the assembly is not in use, store it in a clean, dry area.

### 6.2. Periodic Inspection

1. Remove all lubrication and accumulated film with a suitable commercial degreaser that will not affect paint or plastic material.
2. Make certain that all assembly components are in place. If replacements are necessary, refer to Section 7, REPLACEMENT AND REPAIR.
3. Inspect crimper assembly for worn, cracked, chipped, or broken areas. If damage is evident, return the assembly for evaluation and repair. See Section 7, REPLACEMENT AND REPAIR.

## 7. REPLACEMENT AND REPAIR

Customer-replaceable parts are listed in Figure 3. A complete inventory should be stocked and controlled to prevent lost time when replacement of parts is necessary. Parts other than those listed should be replaced by Tyco Electronics to ensure quality and reliability. Order replacement parts through your representative, or call 1-800-526-5142, or send a facsimile of your purchase order to 717-986-7605, or write to:

CUSTOMER SERVICE (038-035)  
 TYCO ELECTRONICS CORPORATION  
 PO BOX 3608  
 HARRISBURG PA 17105-3608

For customer repair service, call 1-800-526-5136.

## 8. REVISION SUMMARY

Revisions to this instruction sheet include:

- Updated instruction sheet to corporate requirements

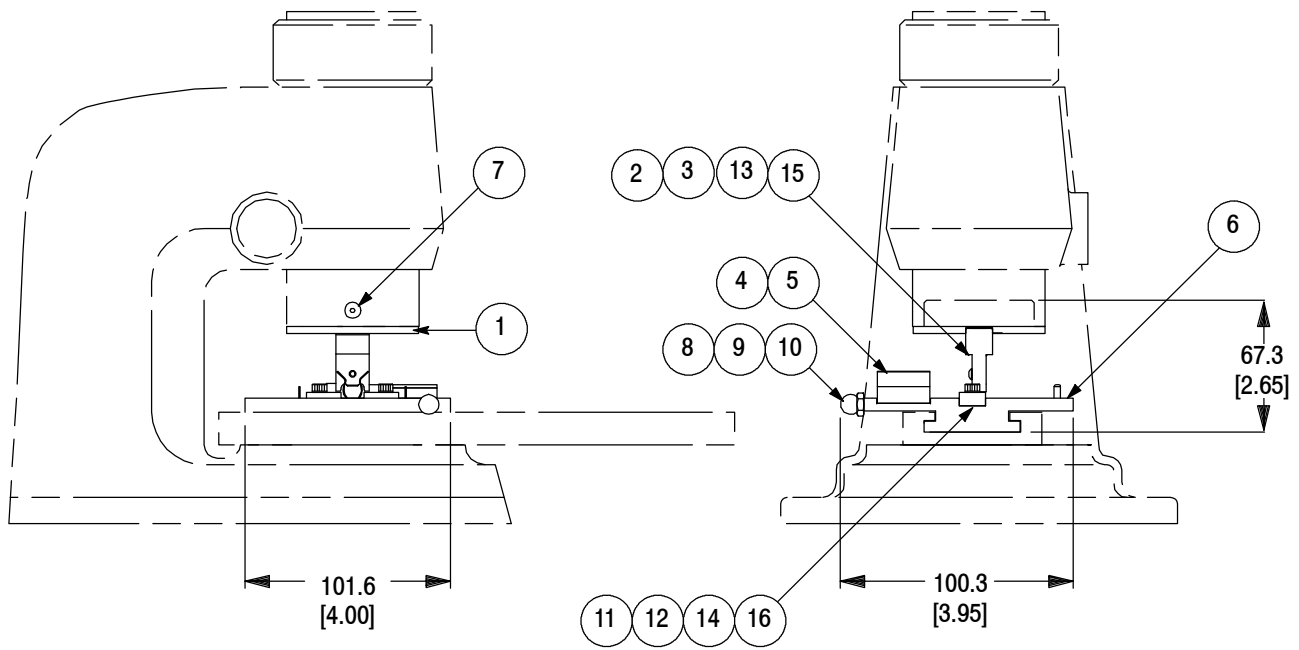

Weight: 1.36 kg [3 lbs]

REPLACEMENT PARTS

ITEM	PART NUMBER	DESCRIPTION	QTY PER ASSEMBLY		
			122842-1	122842-2	122842-3
1	527246-1	TOOL MOUNT	1	1	1
2	122839-1	CRIMPER, 50-Position	1	—	—
3	2-21000-6	SCREW, Socket Head Cap, 8-32 × .38 in.	1	1	1
4	543156-1	SPRING, Cable Clamp	2	2	2
5	2-21000-5	SCREW, Socket Head Cap, 8-32 × .25 in.	2	2	2
6	856593-1	SLIDE	1	1	1
7	1-21003-9	SCREW, Flat Head Cap, 6-32 × .32 in.	2	2	2
8	23673-1	HANDLE, Ball	1	1	1
9	21018-7	NUT, Hex 10-32	1	1	1
10	5-21012-4	SCREW, Set 10-32 × .50 in.	1	1	1
11	122841-1	BLOCK, Support, 50-Position	1	—	—
12	2-21000-7	SCREW, Socket Head Cap, 8-32 × .50 in.	1	1	1
13	189544-1	CRIMPER, 68-Position	—	1	—
14	189543-1	BLOCK, Support, 68-Position	—	1	—
15	189544-2	CRIMPER, 36-Position	—	—	1
16	189543-2	BLOCK, Support, 36-Position	—	—	1

Figure 3