



Crimzon[®] Infrared Microcontrollers

ZLP12840 OTP MCU with Learning Amplification

Product Brief

PB015605-1007



Overview

Zilog's ZLP12840 OTP MCU is a member of the Crimzon[®] MCU family of infrared microcontrollers. With 1 KB of general-purpose RAM and up to 128 KB of OTP, Zilog's CMOS microcontrollers offer fast executing, efficient use of memory, sophisticated interrupts, input/output bit manipulation capabilities, automated pulse generation/reception, and internal key-scan pull-up transistors.

Product Block Diagram

Power-On Reset	32/64/96/128K OTP ROM	T8 Timer Capture and Transmit
High Battery Voltage Detection	Z8[®] LXM Core	T16 Timer Capture and Transmit
Low Battery Voltage Detection		8-Bit Timer w/ UART
2 Comparators	1 KB RAM	Watchdog Timer
Dedicated IR Amplifier		
Port 0 8 I/O	Port 2 8 I/O	Port 3 8 I/O

Features

Key features of ZLP12840 OTP MCU include:

- Low power consumption
- Three standby modes
 - STOP—2 μ A (typical)
 - HALT—0.8 mA (typical)
 - Low-Voltage Reset

- Infrared dedicated timers
 - Capture and transmit, 8- and 16-bit
 - 8-bit timer with full duplex UART
- Twenty priority interrupt sources
 - Three from UART Tx, UART Rx, UART BRG
 - Two assigned to T8, T16 time-out and capture
 - One low-voltage detection interrupt
 - Fourteen from Stop Mode Recovery sources P20–P27, P30–P33, P00, and P04
- High and Low voltage detection with Flag IRQ (Low voltage only)
- Programmable Watchdog Timer
- Power-On Reset circuits
- OTP-selectable pull-up transistors on Port 0 and Port 2
- Two comparators
- Infrared learning amplification comparator
- Up to 24 GPIO
 - Port 0: 0–3 (with pull-up option)
 - Port 0: 4–7 (with pull-up option)
 - Port 2: 0–7 (with pull-up option)
 - Port 3: 0–7
- Flexible Stop Mode Recovery
- Compatible with Zilog's Z86L98, ZLP32300, ZLR32300, and ZLR64400 product families.

Block Diagram

Figure 1 displays the functional block diagram.

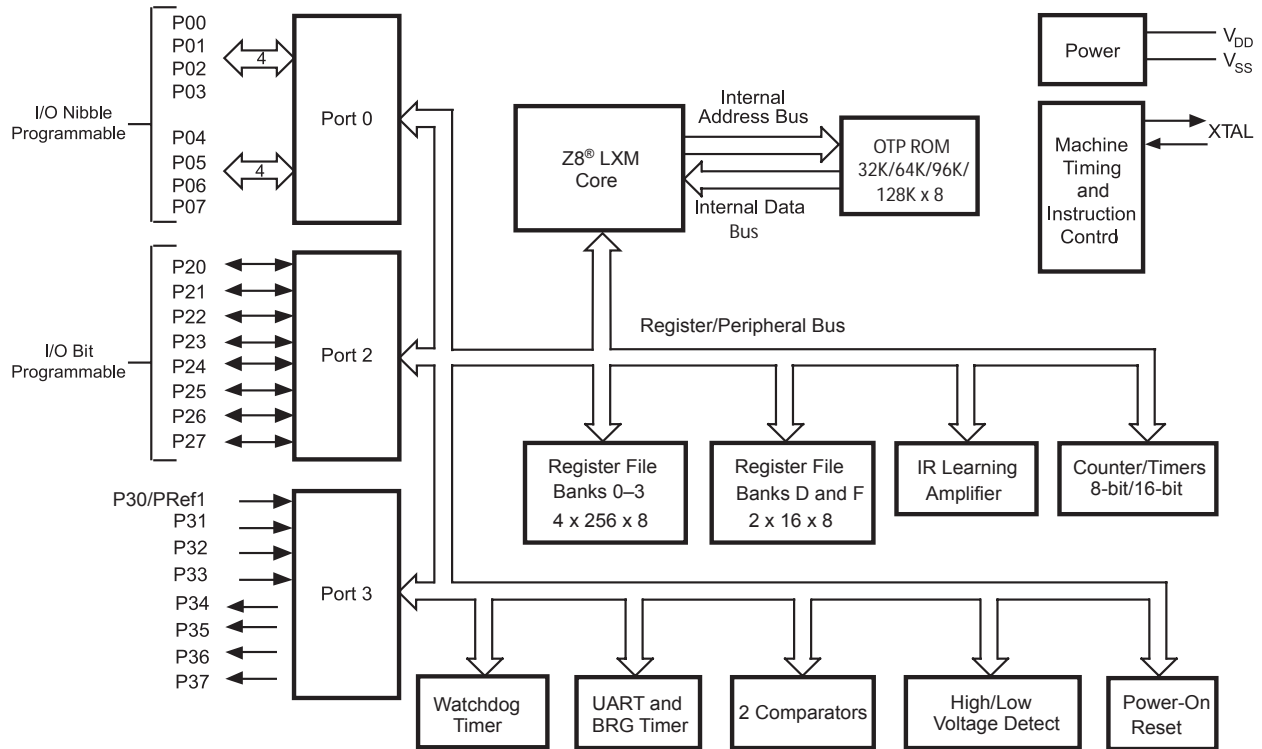

Figure 1. Functional Block Diagram

Pin-Outs and Pin Directions

Figure 2 displays the 20-pin PDIP, SOIC, and SSOP pin assignments.

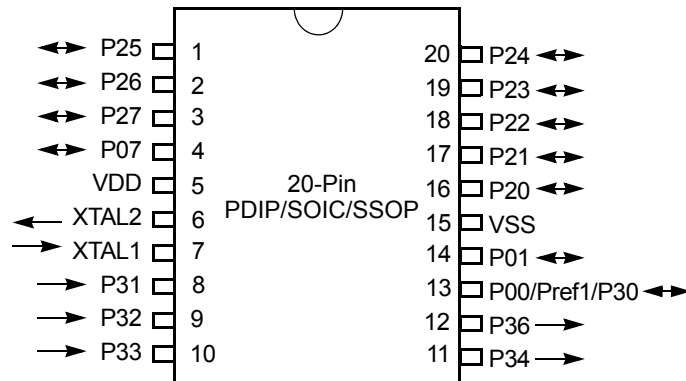

Figure 2. 20-Pin PDIP/SOIC/SSOP Pin Assignment

Figure 3 displays the 28-pin PDIP, SOIC, and SSOP pin assignments.

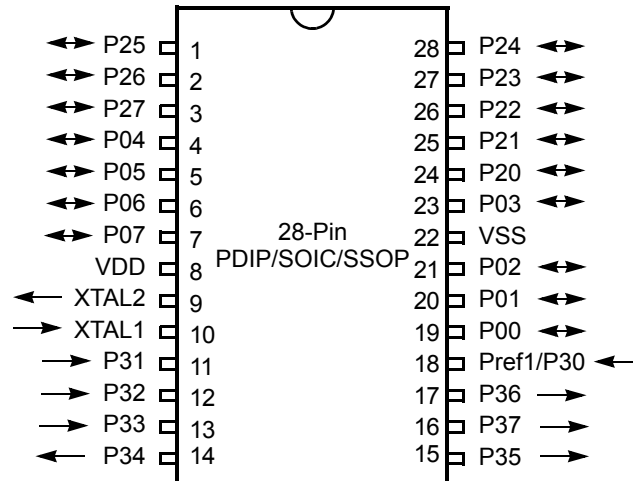

Figure 3. 28-Pin PDIP/SOIC/SSOP Pin Assignment

Applications and Support Tools

The following development tools are available for programming and debugging this device:

- ZCRMZNICE01ZEMG—Crimzon In-Circuit Emulator
- ZCRMZNICE01ZACG—20-pin Accessory Kit to the ZCRMZNICE01ZEMG
- ZCRMZNICE02ZACG—40-/48-pin Accessory Kit to the ZCRMZNICE01ZEMG
- ZCRMZN00100KITG—Crimzon IR Development Kit
- Zilog Developer Studio II (ZDSII), available for download at www.zilog.com

Ordering Information

Each of the parts listed in table is available in a lead-free package that conforms to responsible environmental standards. To order a leaded package, contact [Zilog Customer Service](#). For more information regarding ordering, contact your local Zilog sales office. Zilog web site, www.zilog.com, lists all regional offices and provides additional product information.

Part Number	Description
ZLP12840H2828G	28-pin SSOP 128K OTP
ZLP12840S2828G	28-pin SOIC 128K OTP
ZLP12840P2828G	28-pin PDIP 128K OTP
ZLP12840H2028G	20-pin SSOP 128K OTP
ZLP12840S2028G	20-pin SOIC 128K OTP
ZLP12840P2028G	20-pin PDIP 128K OTP

Part Number	Description
ZLP12840H2896G	28-pin SSOP 96K OTP
ZLP12840S2896G	28-pin SOIC 96K OTP
ZLP12840P2896G	28-pin PDIP 96K OTP
ZLP12840H2096G	20-pin SSOP 96K OTP
ZLP12840S2096G	20-pin SOIC 96K OTP
ZLP12840P2096G	20-pin PDIP 96K OTP
ZLP12840H2864G	28-pin SSOP 64K OTP
ZLP12840S2864G	28-pin SOIC 64K OTP
ZLP12840P2864G	28-pin PDIP 64K OTP
ZLP12840H2064G	20-pin SSOP 64K OTP
ZLP12840S2064G	20-pin SOIC 64K OTP
ZLP12840P2064G	20-pin PDIP 64K OTP
ZLP12840H2832G	28-pin SSOP 32K OTP
ZLP12840S2832G	28-pin SOIC 32K OTP
ZLP12840P2832G	28-pin PDIP 32K OTP
ZLP12840H2032G	20-pin SSOP 32K OTP
ZLP12840S2032G	20-pin SOIC 32K OTP
ZLP12840P2032G	20-pin PDIP 32K OTP
ZCRMZNICE01ZEMG	Crimzon In-Circuit Emulator



Warning: DO NOT USE IN LIFE SUPPORT

LIFE SUPPORT POLICY

ZILOG'S PRODUCTS ARE NOT AUTHORIZED FOR USE AS CRITICAL COMPONENTS IN LIFE SUPPORT DEVICES OR SYSTEMS WITHOUT THE EXPRESS PRIOR WRITTEN APPROVAL OF THE PRESIDENT AND GENERAL COUNSEL OF ZILOG CORPORATION.

As used herein

Life support devices or systems are devices which (a) are intended for surgical implant into the body, or (b) support or sustain life and whose failure to perform when properly used in accordance with instructions for use provided in the labeling can be reasonably expected to result in a significant injury to the user. A critical component is any component in a life support device or system whose failure to perform can be reasonably expected to cause the failure of the life support device or system or to affect its safety or effectiveness.

Document Disclaimer

©2007 by Zilog, Inc. All rights reserved. Information in this publication concerning the devices, applications, or technology described is intended to suggest possible uses and may be superseded. ZILOG, INC. DOES NOT ASSUME LIABILITY FOR OR PROVIDE A REPRESENTATION OF ACCURACY OF THE INFORMATION, DEVICES, OR TECHNOLOGY DESCRIBED IN THIS DOCUMENT. ZILOG ALSO DOES NOT ASSUME LIABILITY FOR INTELLECTUAL PROPERTY INFRINGEMENT RELATED IN ANY MANNER TO USE OF INFORMATION, DEVICES, OR TECHNOLOGY DESCRIBED HEREIN OR OTHERWISE. The information contained within this document has been verified according to the general principles of electrical and mechanical engineering.

Z8, Z8 Encore!, Z8 Encore! XP, Z8 Encore! MC, Crimzon, eZ80, and ZNEO are trademarks or registered trademarks of Zilog, Inc. All other product or service names are the property of their respective owners.