

# VR STAMP™

## WITH SERIAL EEPROM

### VOICE RECOGNITION MODULE

With the **VR Stamp™** from Sensory, you can now add voice recognition, speech output, and music synthesis to any product imaginable.

The VR Stamp is the first rapidly deployable speech module to use Sensory's proprietary **T2Si™** (text to speaker independent) technology, which allows developers to create working recognition sets in minutes. Multiple languages are supported, making the VR Stamp useful for products virtually anywhere in the world.

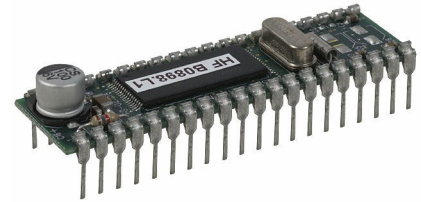

Based on Sensory's award-winning RSC Family of microcontrollers, the VR Stamp is a completely modularized, production ready speech recognition system that allows products to speak and hear with minimal development time and low system cost.

VR Stamp simplifies the integration of speech recognition into products by combining all key components into a small 40-pin DIP footprint module. A low-noise audio channel and standardized packaging allow rapid prototyping, less debugging and shorter time to market. The VR Stamp offers 24 I/O lines, as well as connections for a power, ground, microphone, speaker, and logic-level RS232 interface. With its small size, full suite of development tools and Sensory's world-class **FluentChip™** Technologies, the VR Stamp will change the way you think about speech recognition.

## FEATURES

### FLUENTCHIP TECHNOLOGY CAPABILITIES

- ▶ Noise-robust Speaker Independent (SI) and Speaker Dependent (SD) recognition
- ▶ Many language models now available for international use
- ▶ High quality, 2.4-10.8 kbps speech compression & sound effects with Sensory's "SX" speech output technology
- ▶ Speaker Verification (SVWS) - Noise robust voice password biometric security
- ▶ 8 voice MIDI-compatible music synthesis and Touch Tone (DTMF) synthesis
- ▶ Low power Audio Wakeup from sleep

### INTEGRATED SOLUTION

- ▶ RSC-4128 Speech processor & 1Mbit Flash
- ▶ 128Kb serial EEPROM for data
- ▶ 14.3MHz (main) & 32KHz (time keeping) clocks
- ▶ 24 I/O lines
- ▶ Microphone preamplifier
- ▶ Pulse Width Modulator (PWM) for Speaker
- ▶ Optional DAC output

### LOW POWER REQUIREMENTS

- ▶  $V_{DD} = 2.70V - 3.6V$
- ▶  $I_{ACT} = 26mA @ 3V$
- ▶  $I_{SLEEP} = <20\mu A @ 3V$

Product Brief  
(80-0281-F)



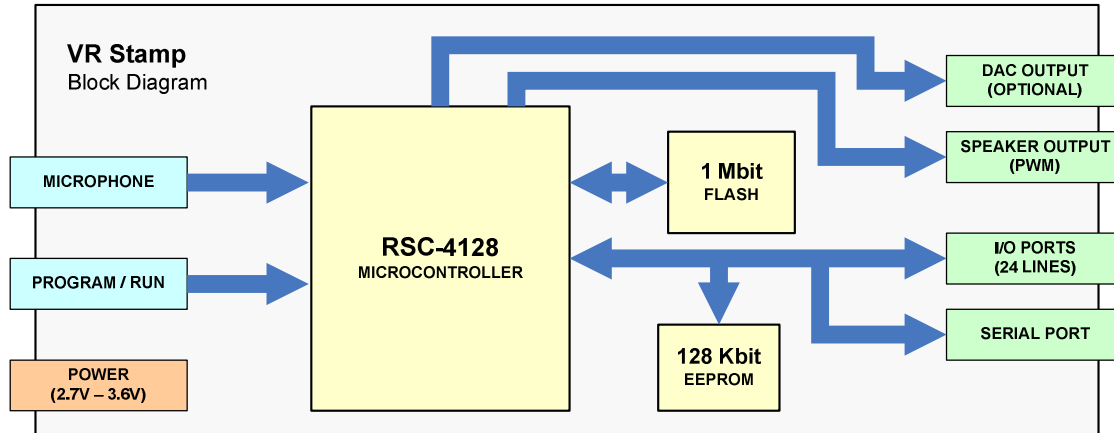

## VR STAMP DEVELOPMENT PLATFORM

The **VR Stamp Toolkit** contains everything necessary to program the VR Stamp to your specifications. Application programs are downloaded onto the VR Stamp module using a Module Programmer Board that has been connected to a PC's USB port. The VR Stamp can then be removed and plugged directly into the final product using an industry standard DIP socket. The VR Stamp Toolkit includes samples and demos of key Sensory technologies that make developing with speech easier than ever. Tools like **QuickSynthesis™ 4** allow recordings of speech to be compressed quickly with the right combination of size and quality. Phyton's Assembler and Linker work together with a limited-life C Compiler to provide a powerful development and coding environment.

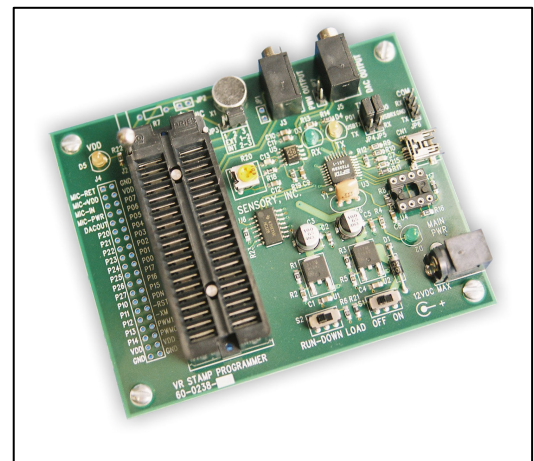

All of the world-class technologies in the FluentChip library are available for use on the VR Stamp, with the exception of Record & Play due to memory constraints.

### THE VR STAMP TOOLKIT ALLOWS YOU TO:

- ▶ Download an application program from the PC to VR Stamp using the Module Programmer Board
- ▶ Develop VR Stamp applications
- ▶ Sample key Sensory speech technologies and Demo common speech applications

### THE PACKAGE CONTAINS:

- ▶ VR Stamp Toolkit CD
    - FluentChip™ and QuickSynthesis™ 4
    - Quick T2SI™ Lite™
  - ▶ Links to Phyton Assembler/Linker
  - ▶ Limited-Life C Compiler
  - ▶ (2) VR Stamps, Serial EEPROM version
  - ▶ Module Programmer Board
- 120v Power Supply, Speaker, USB cable

*includes complete documentation, demos and drivers cutting edge speech technologies and tools for creation of speaker independent vocabularies integrated development environment integrated coding platform for prototyping and/or production for downloading application code and demos everything needed to get started*

575 N. Pastoria Ave. • Sunnyvale, CA 94085

Tel 408.625.3300 • Fax 408.625.3350

www.sensoryinc.com • sales@sensoryinc.com

