

DO NOT SCALE  
DIMENSIONS IN mm

METRIC

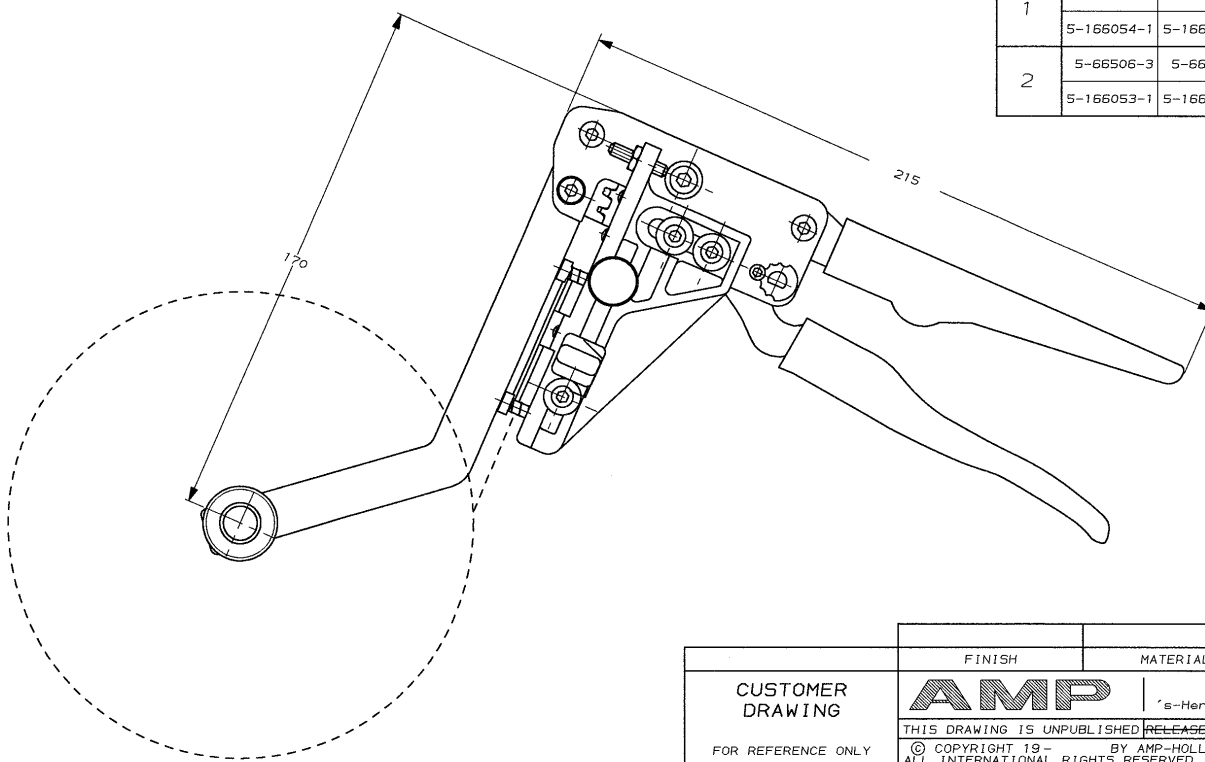

CRIMP NEST	REEL PN		WIRE SIZE	
	PIN	SOCKET	mm <sup>2</sup>	AWG
1	5-66507-3	5-66505-3	0,08-0,22	28-24
	5-166054-1	5-166052-1		
2	5-66506-3	5-66504-3	0,20-0,56	24-20
	5-166053-1	5-166051-1		



		FINISH	MATERIAL	169424-1	PARTNUMBER	
CUSTOMER DRAWING		<b>AMP</b>		AMP-HOLLAND B.V. 's-Hertogenbosch, The Netherlands.		
FOR REFERENCE ONLY WILL NOT BE UPDATED		THIS DRAWING IS UNPUBLISHED © COPYRIGHT 1989 BY AMP-HOLLAND B.V. ALL INTERNATIONAL RIGHTS RESERVED. AMP PRODUCTS MAY BE COVERED BY U.S. AND FOREIGN PATENTS AND/OR PATENTS PENDING.				
DR. P. BEIJNDON	DATE 10-3-88	WIRE RANGE -	NAME REELFED TOOL FOR HD 20 CONT.		REV. DATE D M Y	
CHK. R. VOS	DATE -	INSUL. RANGE -			10 3 89	
APP. L. V. SOEST	DATE -	SIZE A3	SHEET OF 1	DWG. No. 169424	REV. LTR. 0	

8 | 7 | 6 | 5 | 4 | 3 | 2 | 1