

PROPER USE GUIDELINES

Cumulative Trauma Disorders can result from the prolonged use of manually powered hand tools. Hand tools are intended for occasional use and low volume applications. A wide selection of powered application equipment for extended-use, production operations is available.

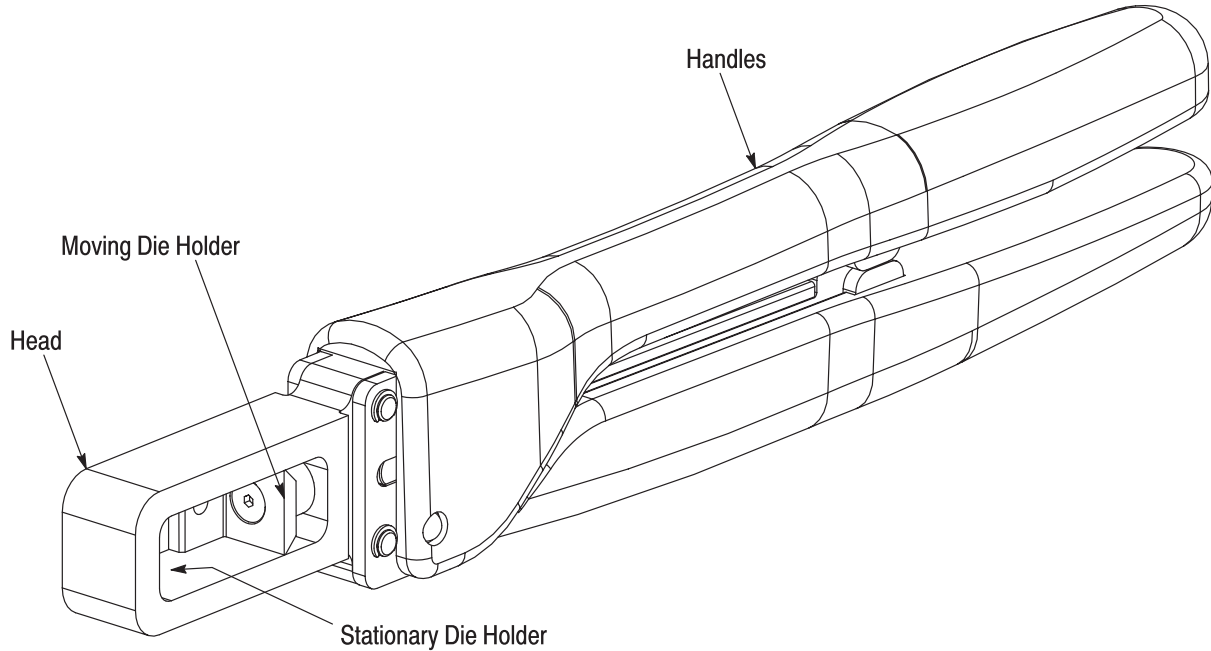



Figure 1

1. INTRODUCTION

CERTI-CRIMP II Die Set Hand Tool 1901260-1 uses interchangeable crimping dies and is used to crimp a wide variety of products. These instructions are general information only. Refer to the instruction sheets packaged with the dies for specific crimping instructions.

NOTE  Dimensions in this instruction sheet are in millimeters [with inches in brackets]. Figures and illustrations are for reference only and are not drawn to scale.



CAUTION The crimping dies bottom before the ratchet releases. This feature ensures maximum electrical and tensile performance of the crimp. **DO NOT** re-adjust the ratchet.

Each set of dies consists of a moving die and a stationary die. Most moving dies have square corners and the stationary dies have chamfered corners. See Figure 2. Exceptions to this feature will be shown on the instruction sheet packaged with the dies.

2. DESCRIPTION (Figure 1)

The tool consists of a head with a stationary die holder and moving die holder and handles with a ratchet.

This tool is a member of the CERTI-CRIMP II hand crimping tool family. The ratchet on this tool ensures full crimping of the product. Once engaged, the ratchet will not release until the handles have been FULLY closed.

Typical Crimping Dies

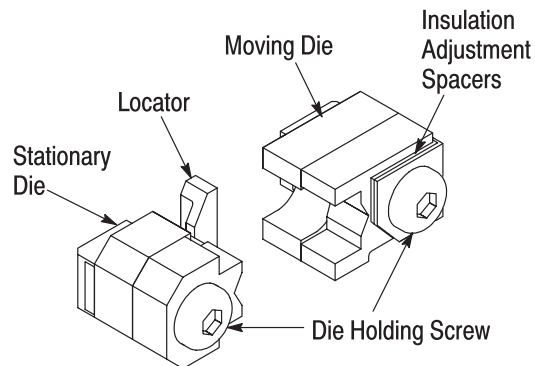

Figure 2

3. DIE INSERTION AND REMOVAL

If the crimping dies require an insulation adjustment, refer to the instruction sheet packaged with dies for the adjustment procedure, then proceed as follows:

1. Close the handles until the ratchet releases. Allow the handles to open.
2. Place the stationary die in the stationary die holder. Turn the die holding screw enough to hold the die in place. DO NOT tighten the screw.
3. Place the moving die in the moving die holder. Turn die holding screw enough to hold die in place. DO NOT tighten the screw.
4. For crimping dies with only one crimping chamber, align the dies, then tighten the die holding screws.
5. For crimping dies with more than one crimping chamber, proceed with the following:
 - a. Position the stationary die in the stationary die holder. Tighten the die holding screw just enough to hold the die in place. DO NOT tighten the screw.
 - b. Position the moving die in the moving die holder. Tighten the die holding screw just enough to hold the die in place. DO NOT tighten the screw.
 - c. With a terminal in position, insert a properly stripped wire, then squeeze the handles until the dies bottom.
 - d. Tighten both the die holding screws while the dies are bottomed.
 - e. Remove the terminal from the dies.
6. To remove the dies, close the tool handles until the ratchet releases, allow the handles to open, loosen the die holding screws, and remove the dies.

4. CRIMPING PROCEDURE

NOTE



The following crimping procedure is typical for most crimping dies used in this tool. Always refer to instruction sheet packaged with the dies for wire preparation and crimping procedure.

1. Place the terminal or splice in the crimping chamber of the stationary die according to the instructions included with the crimping dies.
2. Close the tool handles until the terminal or splice is held firmly in place.
3. For a terminal, insert a properly stripped wire into the wire barrel until the wire butts against the crimping die locator.

For a splice, insert a properly stripped wire into the wire barrel until the wire butts against the splice wire stop.

4. Holding the wire in place, squeeze the tool handles together until the ratchet releases. Allow the handles to open FULLY, and remove the crimped terminal or splice.

5. For a splice, re-position the splice according to the instructions included with the crimping dies.

5. MAINTENANCE AND INSPECTION

It is recommended that a maintenance and inspection program be performed periodically to ensure dependable and uniform terminations. Though recommendations call for at least one inspection a month, frequency of inspection depends on:

1. The care, amount of use, and handling of the tool.
2. The presence of abnormal amounts of dust and dirt.
3. The degree of operator skill.
4. Your own established standards.

The tool is inspected before being shipped; however, it is recommended that the tool be inspected immediately upon arrival to ensure that the tool has not been damaged during shipment.

5.1. Daily Maintenance

1. Immersed the tool (handles partially closed) in a reliable commercial degreasing compound to remove accumulated dirt, grease, and foreign matter. When degreasing compound is not available, the tool may be wiped clean with a soft, lint-free cloth. DO NOT use hard or abrasive objects that could damage the tool.
2. Make certain that the retaining pins are in place and that they are secured with retaining rings.
3. All pins, pivot points, and bearing surfaces should be protected with a THIN coat of any good SAE 20 motor oil. DO NOT oil excessively.
4. When the tool is not in use, keep the handles closed to prevent objects from becoming lodged in the crimping dies. Store the tool in a clean, dry area.

5.2. Periodic Inspection

A. Lubrication

Lubricate all pins, pivot points, and bearing surfaces with any good SAE 20 motor oil as follows:

- Tool used in daily production — daily
- Tool used daily (occasional) — weekly
- Tool used weekly — monthly

Wipe excess oil from the tool, particularly from the crimping area. Oil transferred from the crimping area onto certain terminations may affect the electrical characteristics of an application.

B. Visual Inspection

1. Close the tool handles until the ratchet releases and then allow them to open freely. If they do not open quickly and fully, the spring is defective and must be replaced. See Section 6, REPLACEMENT AND REPAIR.
2. Inspect the head for worn, cracked, or broken crimping dies. If damage is evident, return the tool for evaluation and repair. See Section 6, REPLACEMENT AND REPAIR.
3. Check die alignment and tighten the die holding screws at least twice daily while tool is in use.

5.3. Ratchet Inspection

Check the ratchet to ensure that the ratchet does not release prematurely, allowing the dies to open before they have fully bottomed. Proceed as follows:

1. Remove traces of oil or dirt from the bottoming surfaces of the dies.
2. Obtain a 0.025 mm [.001 in.] shim that is suitable for checking the clearance between the bottoming surfaces of the dies.
3. Select a terminal or splice and *maximum* size wire for the terminal or splice.
4. Position the terminal or splice in the crimping chamber according to the instructions

included with the crimping dies. Holding the wire in place, squeeze the tool handles together until the ratchet releases. Hold the tool handles in this position, maintaining just enough pressure to keep the dies closed.

5. Check the clearance between the bottoming surfaces of the dies. If the clearance is 0.025 mm [.001 in.] or less, the ratchet is satisfactory. If clearance exceeds 0.025 mm [.001 in.], the ratchet is out of adjustment and must be repaired. See Section 6, REPLACEMENT AND REPAIR.

6. REPLACEMENT AND REPAIR

Customer-replaceable parts are listed in Figure 3. A complete inventory should be stocked and controlled to prevent lost time when replacement of parts is necessary. Parts other than those listed should be replaced by Tyco Electronics to ensure quality and reliability. Order replacement parts through your representative, or call 1-800-526-5142, or send a facsimile of your purchase order to 717-986-7605, or write to:

CUSTOMER SERVICE (038-035)
 TYCO ELECTRONICS CORPORATION
 PO BOX 3608
 HARRISBURG PA 17105-3608

For customer repair service, call 1-800-526-5136.

7. REVISION SUMMARY

- Initial release of document

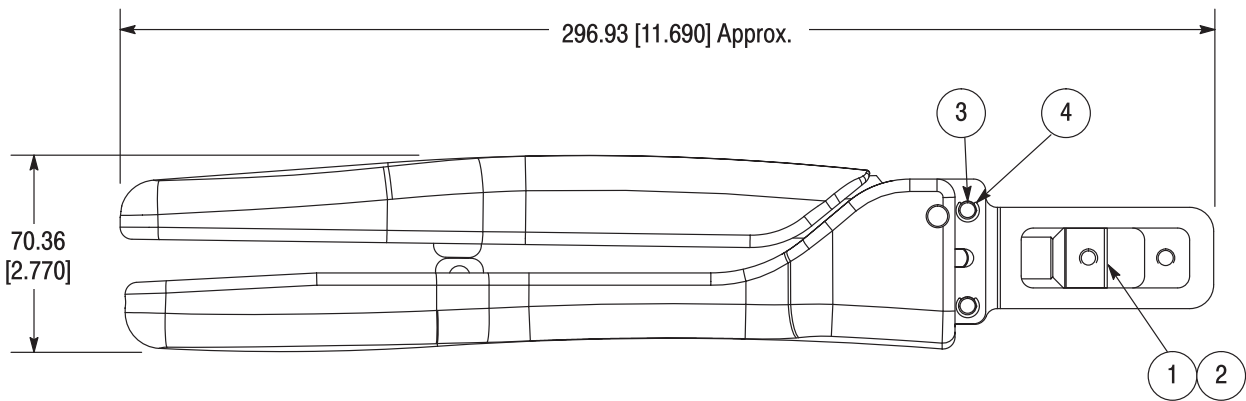

REPLACEMENT PARTS

ITEM	PART NUMBER	DESCRIPTION	QTY PER TOOL
1	1901610-1	DIE HOLDER, Lower	1
2	1-21003-9	SCREW, FLT, Soc Hd Cap 6-32 x .375 LG	1
3	1490759-1	PIN, Grooved	2
4	1428191-3	RING, Retaining	4

Figure 3