

PROPER USE GUIDELINES

Cumulative Trauma Disorders can result from the prolonged use of manually powered hand tools. Hand tools are intended for occasional use and low volume applications. A wide selection of powered application equipment for extended-use, production operations is available.

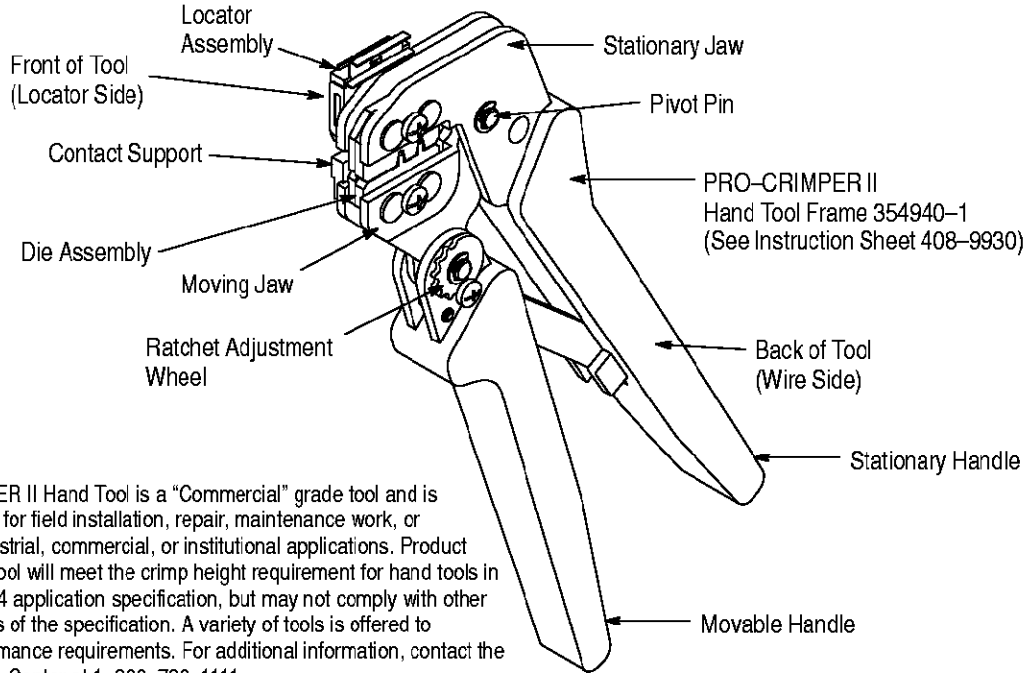

The PRO-CRIMPER II Hand Tool is a "Commercial" grade tool and is designed primarily for field installation, repair, maintenance work, or prototyping in industrial, commercial, or institutional applications. Product crimped with this tool will meet the crimp height requirement for hand tools in the appropriate 114 application specification, but may not comply with other feature parameters of the specification. A variety of tools is offered to satisfy your performance requirements. For additional information, contact the Tooling Assistance Center at 1-800-722-1111.

DIE ASSEMBLY	LOCATOR ASSEMBLY†	PRODUCT FAMILY‡	WIRE		
			SIZE (AWG)	INSULATION DIAMETER (Max.)	STRIP LENGTH
91338-2	58515-1	0.64 mm	20	1.85 [.073]	3.81 [.150]
			18	2.13 [.084]	

† Supplied with die assembly, also available separately.

‡ Contact the Tooling Assistance Center at the number listed below for specific contact part numbers.

Figure 1

1. INTRODUCTION

AMP* PRO-CRIMPER II Hand Tool Assembly 91338-1 consists of Die Assembly 91338-2 and PRO-CRIMPER II Hand Tool Frame 354940-1. The die assembly consists of crimping dies and a locator assembly. Read these instructions thoroughly before crimping any contacts.

NOTE All dimensions on this document are in millimeters [with inches in brackets]. Figures are not drawn to scale.

2. DESCRIPTION

The tool features a tool frame with a stationary jaw and handle, moving jaw, moving handle, and adjustable ratchet that ensures full contact crimping.

The tool frame holds a die assembly with two crimping chambers. See Figure 1.

The die assembly features a wire anvil, insulation anvil, wire crimper, and insulation crimper.

Die retaining pins and die retaining screws are used to position and secure the dies in the tool frame.

Attached to the outside of the frame is a locator assembly, which contains a locator and contact retainer. A nut is used on the upper die retaining screw to hold the locator assembly in place.

Attached to the outside of the jaw is a contact support. A nut is used on the lower die retaining screw to hold the contact support in place.

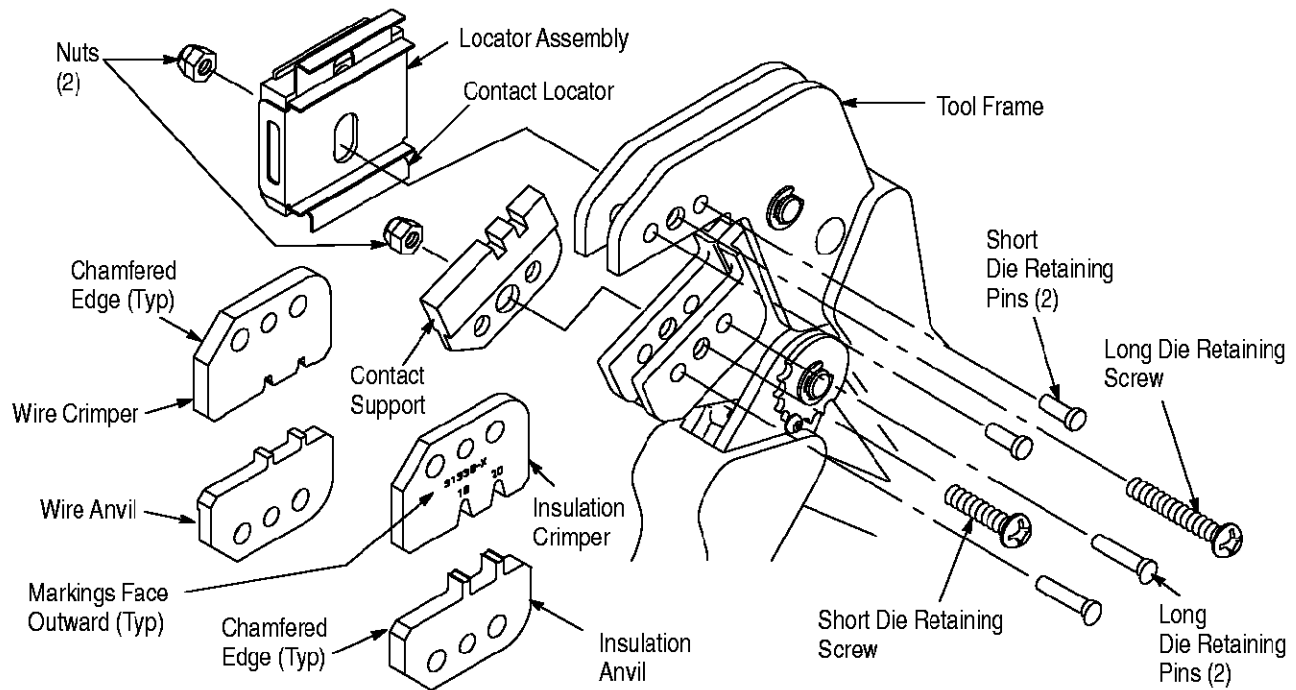

Figure 2

3. INSTALLATION AND REMOVAL OF DIE ASSEMBLY, LOCATOR ASSEMBLY, AND CONTACT SUPPORT

1. Open the tool handles, and remove the two die retaining screws from the tool jaws. See Figure 2.
2. Place the wire anvil and insulation anvil so that the chamfered sides and marked surfaces face outward, when mounted in the moving jaw of the tool frame.
3. Insert two long die retaining pins through the tool frame and the anvils.
4. Insert the short die retaining screw through the jaw and through both anvil dies. Tighten the screw just enough to hold the dies in place. Do *not* tighten the screw completely at this time.
5. Place the wire crimper and insulation crimper so that their chamfered sides and their marked surfaces face outward, when mounted in the stationary jaw of the tool frame.
6. Insert two short die retaining pins through the tool frame and into the crimpers.
7. Insert the long die retaining screw through the jaw and through both crimper dies. Tighten the screw just enough to hold the dies in place. Do *not* tighten the screw completely at this time.
8. Carefully close the tool handles, making sure that the anvils and crimpers align properly. Continue closing the tool handles until the ratchet in the tool frame has engaged sufficiently to hold

the anvils and crimpers in place, then tighten both die retaining screws.

9. Place the locator assembly over the end of the long die retaining screw. Position the locator assembly against the side of the tool jaw.
10. Place a nut onto the end of the long screw and tighten the nut enough to hold the locator assembly in place, while still allowing the contact locator to slide up and down.
11. Place the contact support, with the chamfered side out, over the end of the short screw and long pins. Secure with a nut.
12. To disassemble, close the tool handles until the ratchet releases, remove the two nuts, the locator assembly, the contact support, the two die retaining screws, and the four die retaining pins. Slide the anvils and crimpers out of the tool jaws.

4. CONTACT LOCATOR ADJUSTMENT

NOTE *The contact locator is preset prior to shipment, but a minor adjustment may be necessary.*

1. Make a sample crimp and determine if the contact is straight, bending upward, or bending downward.
2. If adjustment is required, loosen the screw that holds the contact locator onto the locator assembly.

NOTE *The ratchet has detents that create audible clicks as the tool handles are closed.*

3. Place a contact with wire into the proper crimp section and close the tool handles until the ratchet reaches the sixth click, or until the contact locator touches the contact.
4. Slightly loosen the nut that holds the locator assembly onto the tool frame.
5. Move the contact locator as required to eliminate the bending of the contact.
6. Tighten the nut and close the handles until the ratchet releases.
7. Remove and inspect the contact.
8. Make another sample crimp. If the contact is straight, tighten the contact locator screw. If the contact is still being bent during crimping, repeat the adjustment procedure.

5. CRIMPING PROCEDURE

NOTE *This tool is provided with a crimp adjustment feature. Initially, the crimp height should be verified as specified in Section 6, CRIMP HEIGHT INSPECTION, and Section 7, CRIMP HEIGHT ADJUSTMENT, before using the tool to crimp desired contacts.*

Refer to Figure 1, and select wire of the specified size and insulation diameter. Strip the wire to the length indicated, taking care not to nick or cut wire strands. Select an applicable contact and identify the appropriate crimping chamber according to the wire size markings on the tool.

Refer to Figure 3, and proceed as follows:

1. Hold the tool so that the back (wire side) is facing you. Squeeze tool handles together and allow them to open fully.

2. Holding the contact by the mating end, insert the contact – insulation barrel first – through the front of the tool and into the appropriate crimp section.
3. Place the contact into the contact support and position the contact so that the mating end is on the locator side of the tool. Make sure that the open “U” of the wire barrel and insulation barrel face the stationary jaw.
4. Carefully close the tool, positioning the contact so that the movable locator enters the contact wire stop slot between the wire barrel and contact shoulder. Butt the wire barrel against the locator.

CAUTION *Make sure that both sides of the contact insulation barrel are started evenly into the crimping chamber. Do NOT attempt to crimp an improperly positioned contact.*

5. Hold the contact in position, and squeeze the tool handles together until ratchet engages sufficiently to hold the contact in position. Do NOT deform insulation barrel or wire barrel.
6. Insert stripped wire into contact insulation and wire barrels until it is butted against the wire stop, as shown in Figure 3.
7. Holding the wire in place, squeeze tool handles together until ratchet releases. Allow tool handles to open and remove crimped contact.

NOTE *The crimped contact may stick in the crimping area, but can be removed by pushing downward on the top of the locator (see Figure 3).*

8. Check the contact crimp height as described in Section 6, CRIMP HEIGHT INSPECTION. If necessary, adjust the crimp height as described in Section 7, CRIMP HEIGHT ADJUSTMENT.

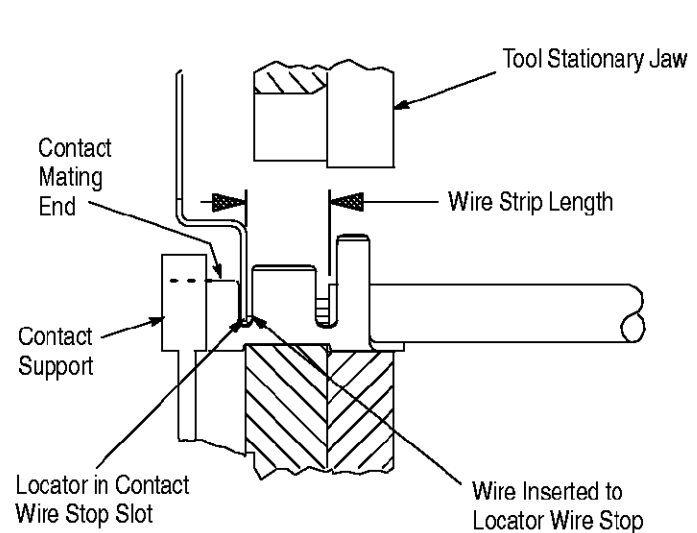
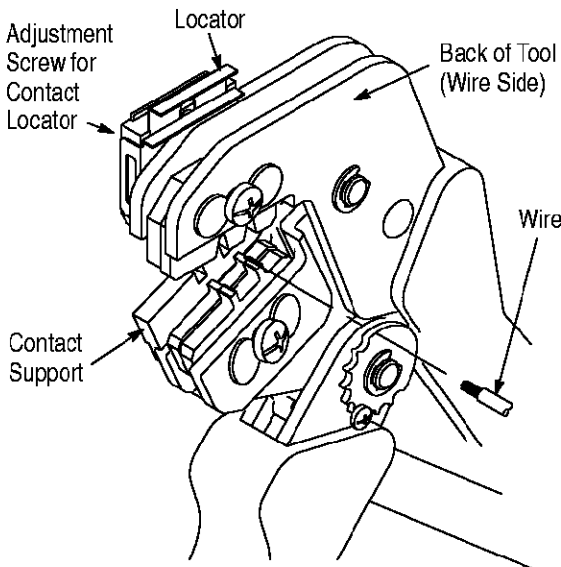
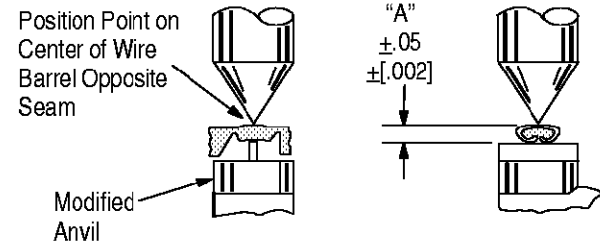

Figure 3

6. CRIMP HEIGHT INSPECTION

This inspection requires the use of a micrometer, with a modified anvil, as shown in Figure 4. A recommendation is the modified micrometer (Crimp Height Comparator RS-1019-5LP) available from:

Shearer Industrial Supply Co. VALCO
20 North Penn Street or 1410 Stonewood Drive
York, PA 17401-1014 Bethlehem, PA 18017-3527



WIRE SIZE AWG (Max.)	CRIMP SECTION MARKING	CRIMP HEIGHT DIMENSION "A"
20	20	1.07 [.042]
18	18	1.19 [.047]

Figure 4

To measure the crimp height:

1. Refer to Figure 4 and select a wire (maximum size) for each crimp section listed in the table.
2. Crimp the contact(s) according to the procedures provided in Section 5, CRIMPING PROCEDURE.
3. Using the crimp height comparator, measure the wire barrel crimp height as shown in Figure 4. If the crimp height conforms to the dimensions provided in Figure 4, then the tool is considered dimensionally correct. If the crimp height does not conform to the dimensions provided, the tool must be adjusted. Refer to Section 7, CRIMP HEIGHT ADJUSTMENT.

For additional information concerning the use of the crimp height comparator, refer to Instruction Sheet 408-7424.

7. CRIMP HEIGHT ADJUSTMENT (Figure 5)

1. Remove the lock screw from the ratchet adjustment wheel.
2. With a screwdriver, adjust the ratchet wheel from the locator side of the tool.
3. Observe the ratchet adjustment wheel. If a tighter crimp is required, rotate the adjustment wheel *counterclockwise* to a higher-numbered setting. If a looser crimp is required, rotate the adjustment wheel *clockwise* to a lower-numbered setting.

4. Re-assemble the lock screw.

5. Make a sample crimp and measure the crimp height. If the dimension is unacceptable, continue to adjust the ratchet, and again measure a sample crimp.

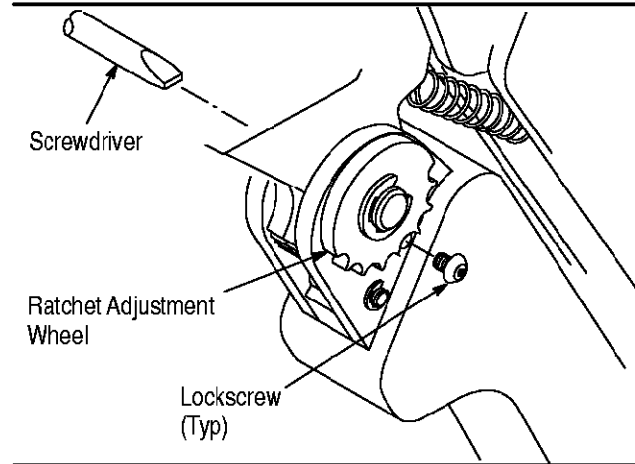

Figure 5

8. MAINTENANCE

Ensure that the tool and dies are clean by wiping them with a clean, soft cloth. Remove any debris with a clean, soft brush. Do not use objects that could damage the tool. When not in use, keep handles closed to prevent objects from becoming lodged in the crimping dies, and store in a clean, dry area.

9. VISUAL INSPECTION

The crimping dies should be inspected on a regular basis to ensure that they have not become worn or damaged. Inspect the crimping chambers for worn, flattened, chipped, or broken areas. If damage or abnormal wear is evident, the tool must be replaced. See Section 10, REPLACEMENT AND REPAIR.

10. REPLACEMENT AND REPAIR

Customer-replaceable parts are shown in Figure 1. Available separately, PRO-CRIMPER II Repair Kit 679221-1 includes a replacement nut and a variety of pins, rings, screws, and springs. If the dies are damaged or worn excessively, they must be replaced. Order repair kit and replaceable parts through your representative, or call 1-800-526-5142, or send a facsimile of your purchase order to 717-986-7605, or write to:

CUSTOMER SERVICE (38-35)
TYCO ELECTRONICS CORPORATION
PO BOX 3608
HARRISBURG, PA 17105-3608

11. REVISION SUMMARY

Per EC 0990-0738-00:

- Initial release of instruction sheet