

### PROPER USE GUIDELINES

Cumulative Trauma Disorders can result from the prolonged use of manually powered hand tools. AMP hand tools are intended for occasional use and low volume applications. AMP offers a wide selection of powered application equipment for extended-use, production operations.

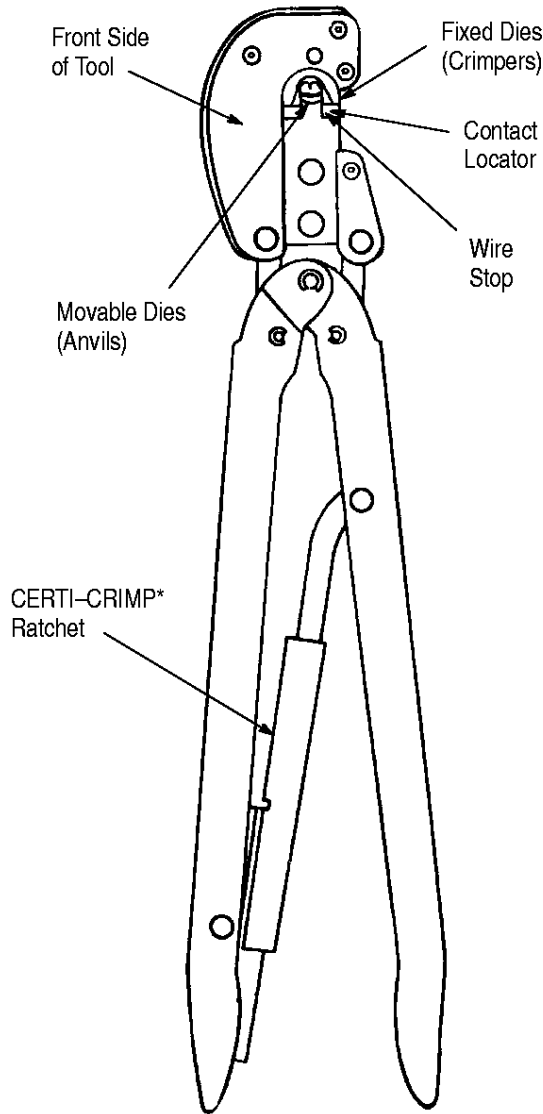

Figure 1

### 1. INTRODUCTION

AMP\* Hand Crimping Tool 90384-1 (shown in Figure 1) is designed to crimp AMP Type XII Male and Female Contacts listed in Figure 2. Read these instructions thoroughly before using the tool.

**NOTE**

*Dimensions are in millimeters [followed by inch equivalents in brackets]. Figures are for identification only and are not drawn to scale.*

Reasons for reissue are provided in Section 6, REVISION SUMMARY.

### 2. DESCRIPTION

The hand tool features two fixed crimping dies (crimpers) and two movable crimping dies (anvils), a contact locator, a wire stop, and a CERTI-CRIMP ratchet. See Figure 1.

The contact locator positions the contact between the crimping dies. In use, the contact locator rests in the locator slot of the contact. The wire stop aids in locating the wire in the contact. In use, the wire stop rests in the wire stop slot of the contact. The CERTI-CRIMP ratchet assures full crimping of the contact. Once engaged, the ratchet will not release until the handles have been fully closed.

**CAUTION**

*The crimping dies bottom before the CERTI-CRIMP ratchet releases. This design feature assures maximum electrical and tensile performance of the crimp. Do NOT re-adjust the ratchet.*

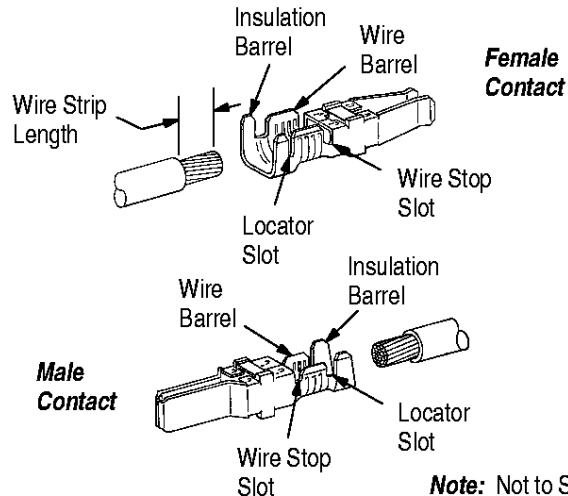

Figure 2

WIRE			CONTACT	
SIZE (AWG)	INSUL DIA	STRIP LENGTH	TYPE	BASE PART NO.
10	4.83-5.59 [.190-.220]	8.33 [.328]	Male	66259
			Male	66260
			Male	66327
			Female	66741

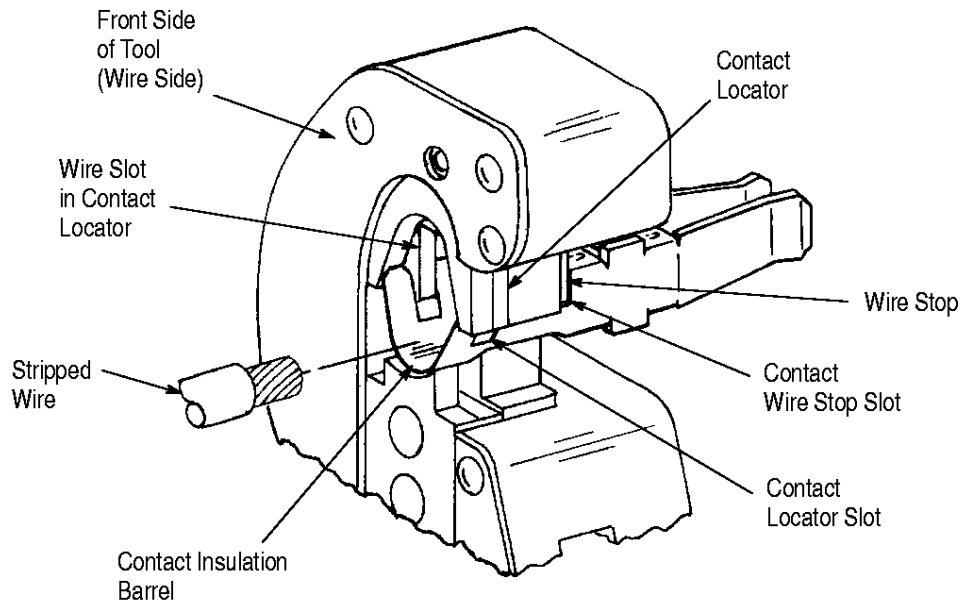

Figure 3

### 3. CRIMPING PROCEDURE

Refer to Figure 2 and select the appropriate contact and wire size for the hand tool. The wire size and insulation diameter must be within the specified range for the contact. Strip the wire to the length shown in Figure 2. Do NOT nick or cut the wire strands.

1. Open crimping dies by squeezing the tool handles together until the CERTI-CRIMP ratchet releases.
2. Insert the contact insulation barrel into the crimping chamber on the anvil crimping die from the BACK side of tool. Position contact so that the contact locator enters the locator slot in the contact. See Figure 3.
3. Holding contact in position, squeeze tool handles together just enough to hold the contact in the crimping dies. Do NOT deform the insulation barrel or wire barrel.
4. Insert stripped wire through wire slot in contact locator and into wire barrel of contact until the wire butts against the wire stop. See Figure 3.
5. Holding wire in place, squeeze tool handles together until ratchet releases.
6. Allow tool handles to open FULLY and remove crimped contact from tool.

### 4. MAINTENANCE AND INSPECTION

AMP recommends that a maintenance and inspection program be performed periodically to ensure

dependable and uniform terminations. Though recommendations call for at least one inspection a month, frequency of inspection depends on:

- The care, amount of use, and handling of the hand tool,
- The presence of abnormal amounts of dust and dirt,
- The degree of operator skill, and
- Your own established standards.

The hand tool is inspected before being shipped; however, AMP recommends that the tool be inspected immediately upon arrival at your facility to ensure that the tool has not been damaged during shipment.

#### 4.1. Daily Maintenance

1. Hand tool should be immersed (handles partially closed) in a reliable commercial degreasing compound to remove accumulated dirt, grease, and foreign matter. When degreasing compound is not available, tool may be wiped clean with a soft, lint-free cloth. Do NOT use hard or abrasive objects that could damage the tool.
2. Make certain that the retaining pins are in place and that they are secured with retaining rings.
3. All pins, pivot points, and bearing surfaces should be protected with a THIN coat of any good SAE 20 motor oil. Do NOT oil excessively.
4. When the tool is not in use, keep handles closed to prevent objects from becoming lodged in the crimping dies. Store the tool in a clean, dry area.

## 4.2. Periodic Inspection

### A. Lubrication

Lubricate all pins, pivot points, and bearing surfaces with SAE 20 motor oil as follows:

- Tool used in daily production—lubricate daily
- Tool used daily (occasional)—lubricate weekly
- Tool used weekly—lubricate monthly

Wipe excess oil from tool, particularly from crimping area. Oil transferred from the crimping area onto certain terminations may affect the electrical characteristics of an application.

### B. Visual Inspection

1. Close tool handles until ratchet releases and then allow them to open freely. If they do not open quickly and fully, the spring is defective and must be replaced. See Section 5, REPLACEMENT AND REPAIR.
2. Inspect head assembly for worn, cracked, or broken dies. If damage is evident, return the tool to AMP for evaluation and repair. See Section 5, REPLACEMENT AND REPAIR.

### C. Crimp Height Inspection

This inspection requires the use of a modified micrometer with a modified anvil and spindle, as shown in Figure 4. AMP recommends the Crimp Height Comparator RS-1019-5LP which can be purchased from:

Shearer Industrial Supply Co.      VALCO  
20 North Penn Street      or      1410 Stonewood Drive  
York, PA 17401-1014      Bethlehem, PA 18017-3527

Proceed as follows:

1. Select a contact and wire for the crimping chamber.
2. Refer to Section 3, CRIMPING PROCEDURE, and crimp the contact accordingly.
3. Using the crimp height comparator, measure the wire barrel crimp height as shown in Figure 4. If the crimp height conforms to that height, the tool is considered dimensionally correct. If not, the tool must be returned to AMP for evaluation and repair. See Section 5, REPLACEMENT AND REPAIR.

For additional information concerning the use of the crimp height comparator, refer to AMP instruction sheet 408-7424.

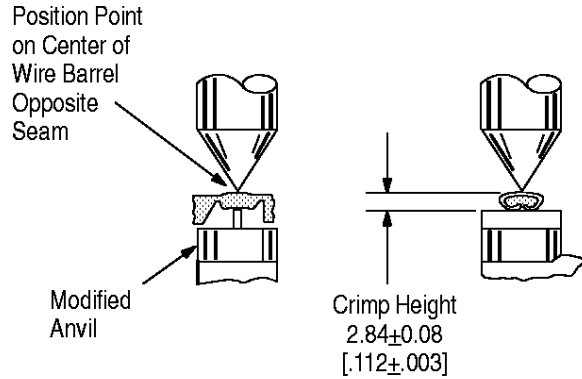

Figure 4

### D. CERTI-CRIMP Ratchet Inspection

The CERTI-CRIMP ratchet feature on AMP hand tools should be checked to ensure that the ratchet does not release prematurely, allowing the crimping dies to open before they have fully bottomed. Obtain a 0.025 [.001] shim that is suitable for checking the clearance between the bottoming surfaces of the crimping dies. Proceed as follows:

1. Select a contact and wire for the tool.
2. Position the contact and wire between the crimping dies, as described in Section 3, CRIMPING PROCEDURE.
3. Holding wire in place, squeeze the handles until the CERTI-CRIMP ratchet releases. Hold the handles in this position, maintaining just enough tension to keep the dies closed.
3. Check the clearance between the bottoming surfaces of the crimping dies. If the clearance is 0.025 [.001] or less, the ratchet is satisfactory. If clearance exceeds 0.025 [.001], the ratchet is out of adjustment and must be repaired. See Section 5, REPLACEMENT AND REPAIR.

## 5. REPLACEMENT AND REPAIR

The parts listed in Figure 5 are customer-replaceable. A complete inventory can be stocked and controlled to prevent lost time when replacement of parts is necessary. Parts other than those listed should be replaced by AMP to ensure quality and reliability of the tool. Order replacement parts through your AMP representative, or call 1-800-526-5142, or send a facsimile of your purchase order to 717-986-7605, or write to:

CUSTOMER SERVICE (38-35)  
AMP INCORPORATED  
P.O. BOX 3608  
HARRISBURG, PA 17105-3608

Tools may also be returned to AMP for evaluation and repair. For tool repair service, contact an AMP representative at: 1-800-526-5136.

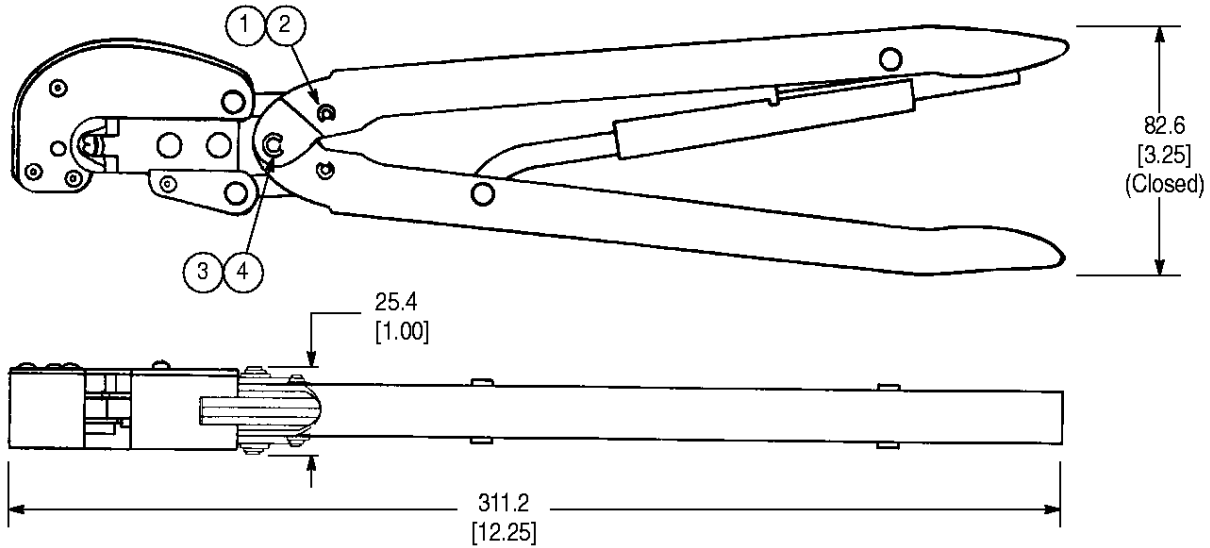

Weight: 936 g [2 lb, 1 oz]

**CUSTOMER REPLACEMENT PARTS**

ITEM	PART NUMBER	DESCRIPTION	QTY PER TOOL
1	21045-3	RING, Retaining	4
2	300388	PIN, Retaining	2
3	21045-6	RING, Retaining	2
4	300389	PIN, Retaining	1

Figure 5

**6. REVISION SUMMARY**

The following changes were made since the previous release of this sheet:

Per EC 0990-0725-99

- Changed tool repair service information in Section 5, REPLACEMENT AND REPAIR
- Updated document format