

PROPER USE GUIDELINES

Cumulative Trauma Disorders can result from the prolonged use of manually powered hand tools. Hand tools are intended for occasional use and low volume applications. A wide selection of powered application equipment for extended-use, production operations is available.

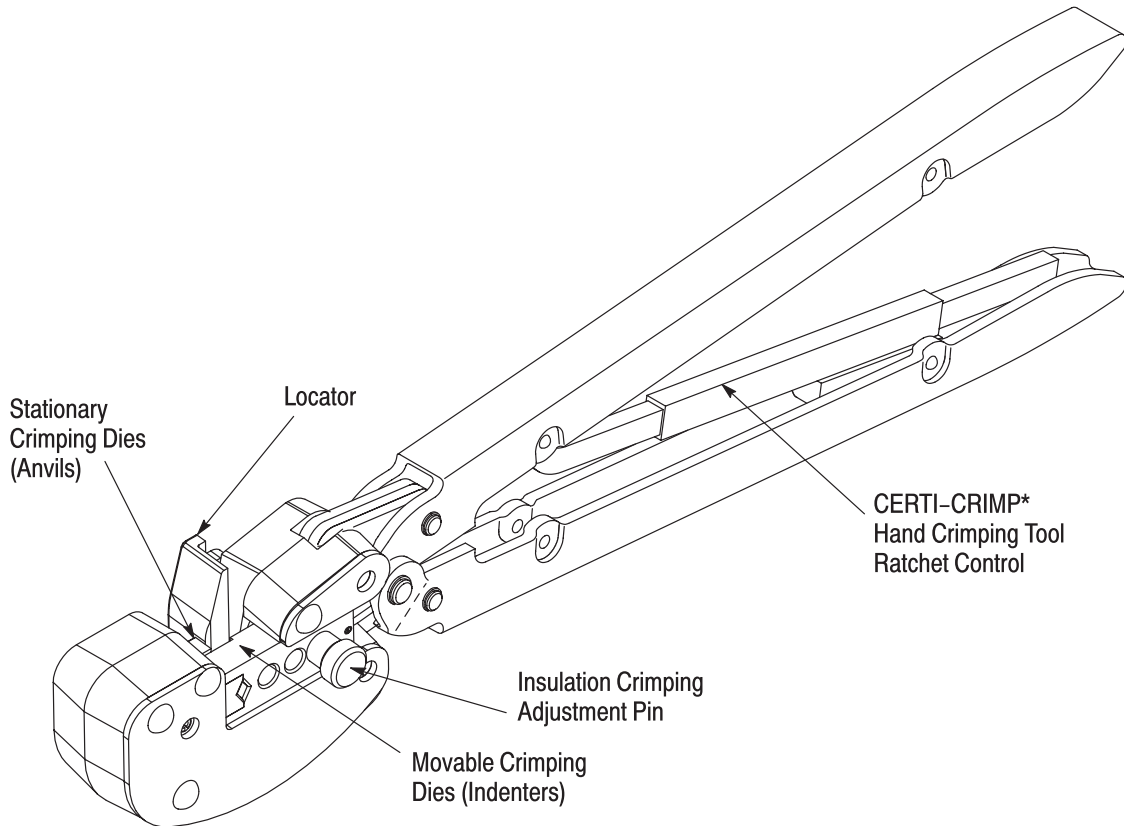

Figure 1

1. INTRODUCTION

This instruction sheet covers hand crimping tools 576778, 576779, 576780, 576781, 576782, 576783, and 576784 which are used to crimp PIDG STRATO-THERM Terminals to the wire sizes listed in Figure 2.



Dimensions on this instruction sheet are in millimeters [with inches in brackets]. Figures and illustrations are for identification only and are not drawn to scale.

2. DESCRIPTION

Each tool features a head containing two stationary crimping dies (anvils) and two movable crimping dies (indenters), a locator, an insulation crimping adjustment pin, and a CERTI-CRIMP hand crimping tool ratchet control. See Figure 1.

When closed, the crimping dies form one crimping chamber with two sections: an insulation barrel section and a wire barrel section. The insulation barrel section crimps the terminal onto the wire insulation and, simultaneously, the wire barrel section crimps the terminal wire barrel onto the stripped wire. The locator positions the terminal in the crimping chamber. The insulation crimping adjustment pin is used to regulate the height of the insulation crimp.

The CERTI-CRIMP hand crimping tool ratchet control ensures full crimping of the terminal. Once engaged, the ratchet will not release until the tool handles have been FULLY closed.



The crimping dies bottom before the CERTI-CRIMP hand crimping tool ratchet control releases. This design feature ensures maximum electrical and tensile performance of the crimp. Do NOT re-adjust the ratchet.

HAND TOOL PART NUMBER	WIRE SIZE (AWG)	DOT CODE	HANDLE COLOR CODE	TERMINAL COLOR CODE		STRIP LENGTH	
				HIGH TEMP.	LOW TEMP.	Min.	Max.
576778	24-22	2 Dots	1 Handle Black 1 Handle Brown	Brown	Black	5.56 [.219]	6.35 [.250]
576779	20	1 Dot	1 Handle Gray 1 Handle Purple	Gray	Purple (With Black Stripe)	5.56 [.219]	6.35 [.250]
576780	18	2 Dots	1 Handle Orange 1 Handle Black	Orange	Orange (With Black Stripe)	5.56 [.219]	6.35 [.250]
576781	16	1 Dot	2 Handles Orange	Orange	Orange (With Black Stripe)	5.56 [.219]	6.35 [.250]
576782	14	2 Dots	1 Handle White 1 Handle Black	White	White (With Black Stripe)	5.56 [.219]	6.35 [.250]
576783	12	1 Dot	2 Handles White	White	White (With Black Stripe)	5.56 [.219]	6.35 [.250]
576784	10	1 Dot	2 Handles Black	Black	---	7.62 [.300]	8.38 [.330]

Figure 2

3. CRIMPING PROCEDURE

NOTE
Refer to Section 5 for information on the insulation crimp adjustment.

Refer to Figure 3 and the following steps for terminal crimping procedures.



Do NOT use wire with nicked or missing conductors.



Make sure terminal insulation color code matches tool handle color.

PIDG STRATO-THERM Terminals

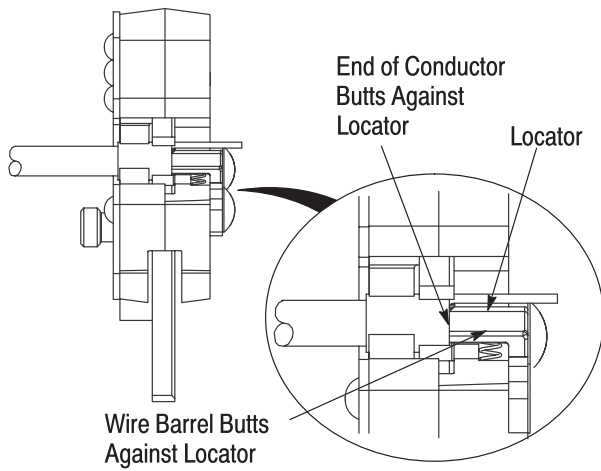
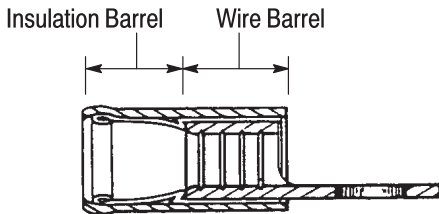

Figure 3

1. Strip the wire to the dimension provided in Figure 2, being careful to avoid nicking or damaging the conductor(s).

2. Open the tool jaws by closing the tool handles until the ratchet releases, then allow the handles to open fully.
3. Place the terminal in the dies so that the wire barrel butts against the locator.
4. Close the tool handles until the terminal is held firmly in place. Do NOT deform the terminal.
5. Insert properly stripped wire into the terminal until the end of the conductor butts against the locator.



Do NOT allow wire insulation to enter the terminal wire barrel.

6. Complete the crimp by closing the tool handles until the ratchet releases.
7. Release the tool handles, allow the handles to open fully, and remove the crimped terminal.
8. Observe the dot code on the finished crimp to ensure that the correct terminal and tool combination was used. See Figure 2.
9. Refer to Section 4 and Figure 4 for terminal crimp inspection procedure.

4. CRIMP INSPECTION

Inspect crimped terminals by checking the features described in Figure 4. Terminals, not meeting the described conditions should NOT Be used.

5. INSULATION CRIMP ADJUSTMENTS

The insulation crimping section of the hand tool has three positions: 1 (tight), 2 (medium), and 3 (loose). To adjust the section:

1. Insert the insulation crimp adjustment pins into the No. 3 position. Refer to Figure 1.
2. Place the terminal into the crimping jaws as shown in Figure 3.
3. Insert the UNSTRIPPED wire into ONLY the insulation barrel (refer to Figure 3) portion of the terminal.

4. Close the tool handles to complete the crimp.

5. Removed the crimped terminal and check the insulation crimp by bending the wire back and forth once. The terminal should retain its grip on the wire insulation. If the wire pulls out, set the insulation crimp adjustment pins to the next higher position (No. 2).

6. Perform another crimp and repeat the adjustment as necessary until the correct insulation grip is attained. Do not use a tighter setting than required.

CAUTION



Make sure that both insulation crimp adjustment pins are in the same position.

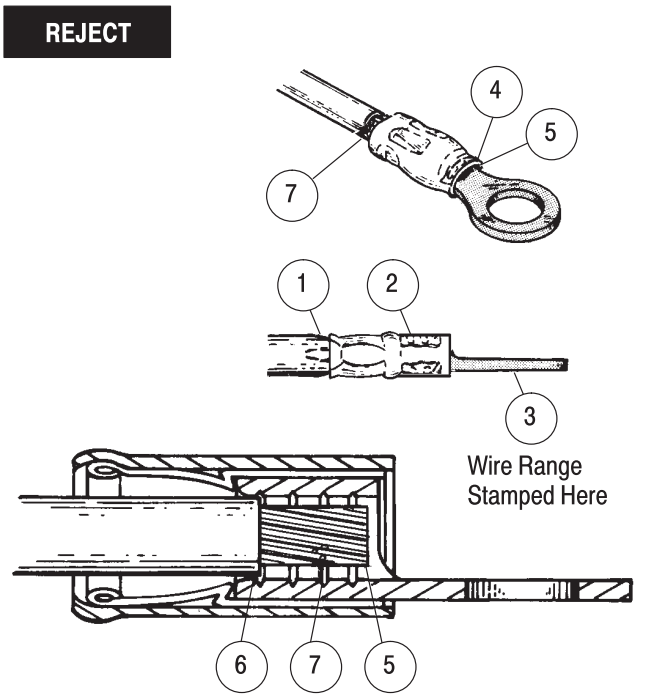
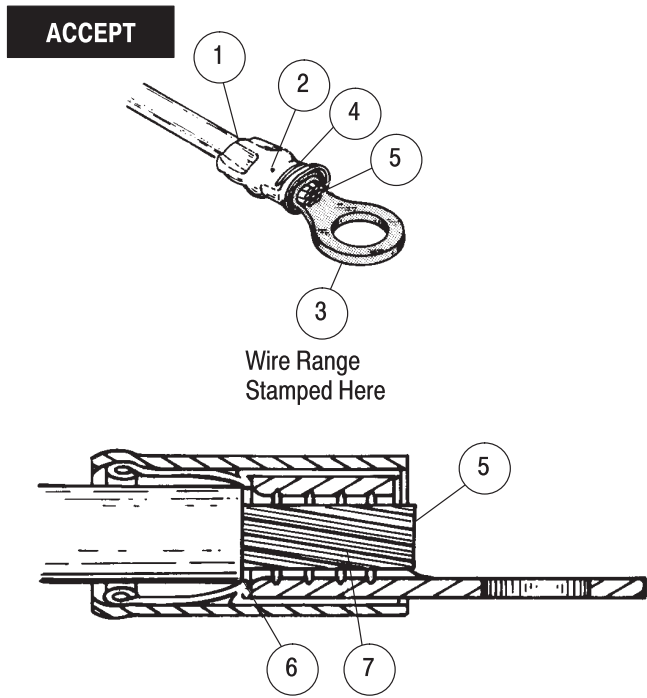

- 1 Insulation barrel is in firm contact with wire insulation.
- 2 Correct color code, dot code, and tool combination.
- 3 Wire size is within wire range stamped under terminal tongue.
- 4 Crimp centered on wire barrel.
- 5 End of conductor is flush with, or extends beyond end of terminal wire barrel.
- 6 Wire insulation does not enter wire barrel.
- 7 No nicked or missing conductor strands.

- 1 Wire insulation extruded. (Insulation crimp too tight on terminals.) See Paragraph 5.1.
- 2 Wrong dot code and color code combination. See Figure 2.
- 3 Wire size is not within wire range stamped on terminal tongue.
- 4 Crimp not centered on wire barrel. (Terminal was not butted against locator. See Figure 4.)
- 5 End of conductor is not flush with or extending beyond end of wire barrel. (Check for correct strip length.)
- 6 Wire insulation entered wire barrel.
- 7 Nicked or missing conductor strands.

Figure 4

6. MAINTENANCE AND INSPECTION PROCEDURE

Tyco Electronics recommends that a maintenance and inspection program be performed periodically to ensure dependable and uniform terminations. Though recommendations call for at least one inspection a month, frequency of inspection depends on:

1. The care, amount of use, and handling of the hand tool.
2. The presence of abnormal amounts of dust and dirt.
3. The degree of operator skill.
4. Your own established standards.

The hand tool is inspected before being shipped; however, Tyco Electronics recommends that the tool be inspected immediately upon arrival to ensure that the tool has not been damaged during shipment.

6.1. Daily Maintenance

1. Hand tool should be immersed (handles partially closed) in a reliable commercial degreasing compound to remove accumulated dirt, grease, and foreign matter. When degreasing compound is not available, tool may be wiped clean with a soft, lint-free cloth. Do NOT use hard or abrasive objects that could damage the tool.
2. Make certain that the retaining pins are in place and that they are secured with retaining rings.
3. All pins, pivot points, and bearing surfaces should be protected with a THIN coat of any good SAE 20 motor oil. Do not oil excessively.
4. When the tool is not in use, keep handles closed to prevent objects from becoming lodged in the crimping jaws. Store the tool in a clean, dry area.

6.2. Periodic Inspection

A. Lubrication

Lubricate all pins, pivot points, and bearing surfaces with SAE 20 motor oil as follows:

- Tool used in daily production – lubricate daily
- Tool used daily (occasional) – lubricate weekly
- Tool used weekly – lubricate monthly

Wipe excess oil from tool, particularly from crimping area. Oil transferred from the crimping area onto certain terminations may affect the electrical characteristics of an application.

B. Visual Inspection

1. Close tool handles until ratchet releases and then allow them to open freely. If they do not open

quickly and fully, the spring is defective and must be replaced. See Section 7, REPLACEMENT AND REPAIR.

2. Inspect head assembly for worn, cracked, or broken jaws. If damage is evident, return the tool to Tyco Electronics for evaluation and repair. See Section 7, REPLACEMENT AND REPAIR.

C. Crimping Die Closure Inspections

Each tool is inspected for proper die closure before shipment. However, inspection of die closure for excessive wear is required periodically.

This inspection requires the use of plug gages conforming to the dimension shown in Figure 5. Tyco Electronics does not manufacture or market these gages.

To gage die closure, refer to Figure 6 and proceed as follows:

1. Remove traces of oil or dirt from the crimping chamber and plug gage.
2. Close the tool handles until the wire barrel dies are bottomed. Do not apply additional pressure to the tool handles.
3. With wire barrel dies bottomed, inspect the wire barrel crimp die closure using the proper plug gage. Press the spring-loaded locator down and hold gage in alignment with the die closure.
4. Align the GO element with the wire barrel section of the crimping chamber. Push element straight into the crimping chamber without using force. The GO element must pass completely through the crimping chamber. See Figure 6.
5. Align the NO-GO element and try to insert it straight into the same section of the crimping chamber. The NO-GO element may start entry, but must not pass completely through the crimping chamber. See Figure 6.
6. Insert tool insulation crimping adjustment pin into Position 1.
7. With crimping dies bottomed, check the insulation barrel section of the crimping chamber as described in Steps 4 and 5.

If the crimping chamber conforms to the gage inspection, the tool is considered dimensionally correct, and should be lubricated with a THIN coat of any good SAE 20 motor oil. If not, the tool must be returned to Tyco Electronics for further evaluation and repair. Refer to Section 7, REPLACEMENT AND REPAIR.

For additional information regarding the use of plug gages, refer to Instruction Sheet 408-7424.

Suggested Plug Gage Design for Wire Barrel Section of Crimping Chamber

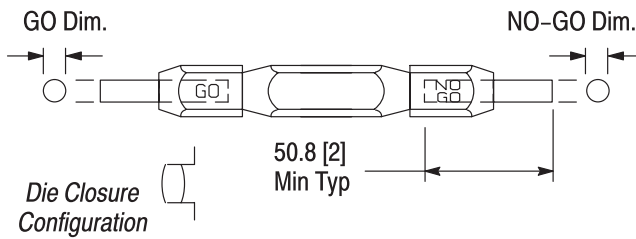

Suggested Plug Gage Design for Insulation Barrel Section of Crimping Chamber

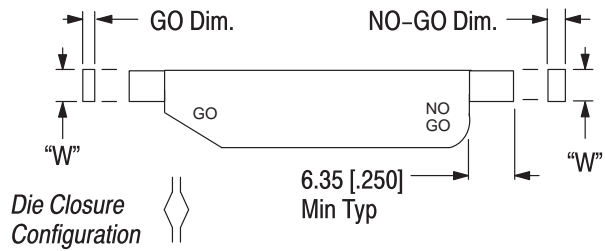

HAND TOOL	WIRE BARREL CRIMP CHAMBER		INSULATION BARREL CRIMP CHAMBER		
	GO	NO-GO	GO	NO-GO	WIDTH (W)
576778	2.591-2.598 [.1020-.1023]	2.690-2.692 [.1059-.1060]	0.813-0.820 [.0320-.0323]	1.217-1.219 [.0479-.0480]	4.06 [.160]
576779	2.591-2.598 [.1020-.1023]	2.690-2.692 [.1059-.1060]	1.067-1.074 [.0420-.0423]	1.471-1.473 [.0579-.0580]	4.39 [.173]
576780	3.048-3.056 [.1200-.1203]	3.147-3.150 [.1239-.1240]	0.940-0.947 [.0370-.0373]	1.344-1.346 [.0529-.0530]	5.89 [.232]
576781	3.124-3.132 [.1230-.1233]	3.223-3.226 [.1269-.1270]	0.940-0.947 [.0370-.0373]	1.344-1.346 [.0529-.0530]	5.89 [.232]
576782	3.327-3.335 [.1310-.1313]	3.426-3.429 [.1349-.1350]	1.067-1.074 [.0420-.0423]	1.471-1.473 [.0579-.0580]	6.63 [.261]
576783	3.683-3.691 [.1450-.1453]	3.782-3.785 [.1489-.1490]	1.067-1.074 [.0420-.0423]	1.471-1.473 [.0579-.0580]	6.63 [.261]
576784	4.775-4.783 [.1880-.1883]	4.874-4.877 [.1919-.1920]	1.676-1.684 [.0660-.0663]	2.080-2.083 [.0819-.0820]	8.43 [.332]

Figure 5

(Detail A) Inspection of Wire Barrel Crimping Dies

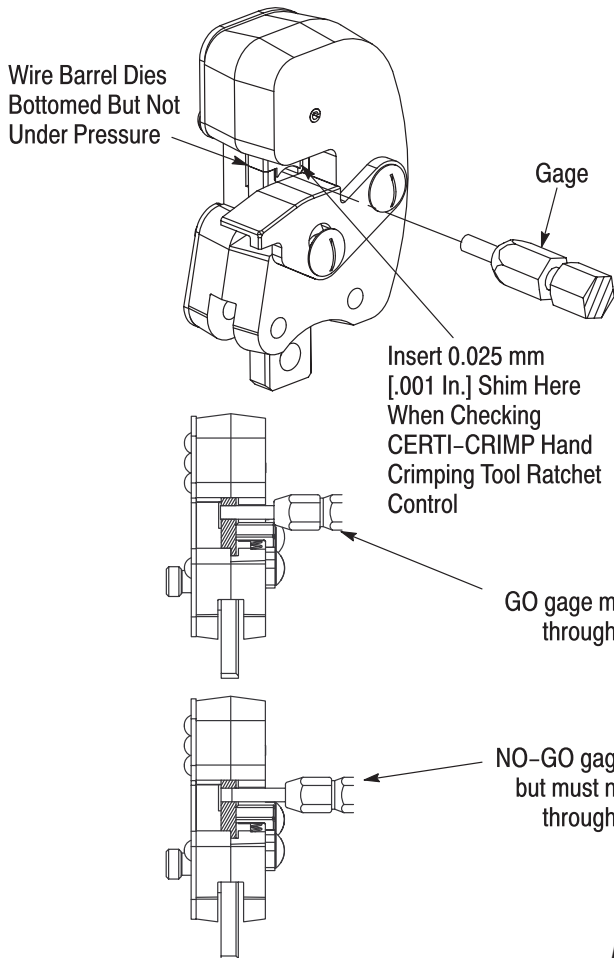

(Detail B) Inspection of Insulation Crimping Dies

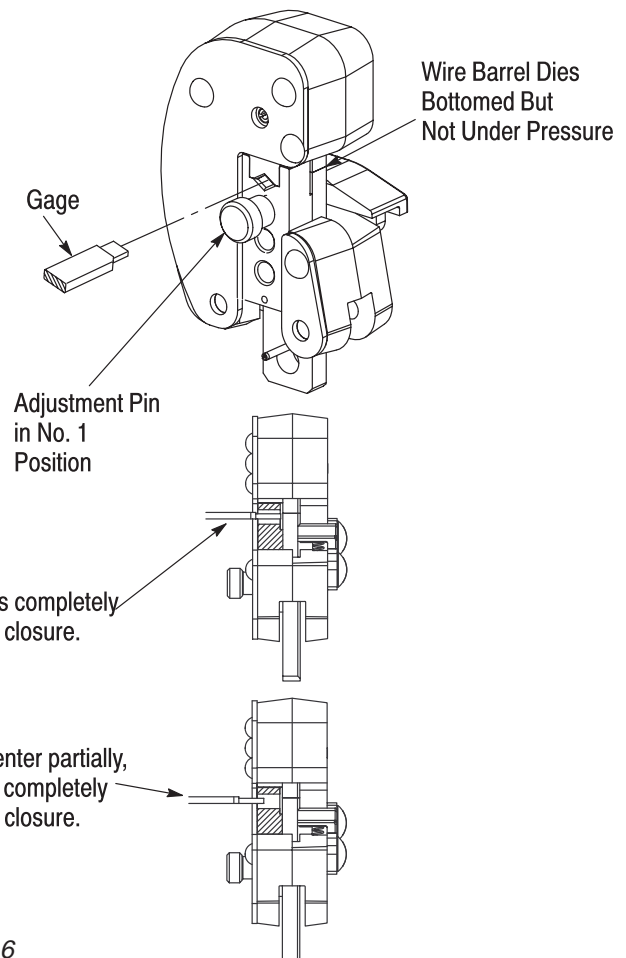

Figure 6

D. CERTI-CRIMP Hand Crimping Tool Ratchet Control Inspection

The CERTI-CRIMP hand crimping tool ratchet control feature on Tyco Electronics hand tools should be checked to ensure that the ratchet does not release prematurely, allowing the dies to open before they have fully bottomed. Obtain a 0.025 mm [.001 in.] shim that is suitable for checking the clearance between the bottoming surfaces of the crimping dies. Proceed as follows:

1. Select the *maximum* size wire for the tool and a terminal.
2. Position the terminal and wire between the crimping dies as described in Section 3.
3. Hold wire in place and squeeze tool handles until the CERTI-CRIMP hand crimping tool ratchet control releases. Hold the handles in this position, maintaining just enough tension to keep the dies closed.
4. Check the clearance between the bottoming surfaces of the crimping dies with the 0.025 mm [.001 in.] shim. If the clearance is 0.025 mm [.001 in.] or less, the ratchet is considered

satisfactory. If the clearance exceeds 0.025 mm [.001 in.], the ratchet is out of adjustment and must be repaired.

7. REPLACEMENT AND REPAIR

Replaceable parts are listed in Figure 7. Parts other than those listed in Figure 7 should be replaced by Tyco Electronics to ensure quality and reliability of the tool. Order replacement parts through your Tyco Electronics Representative, or call 1-800-526-5142, or send a facsimile of your purchase order to 1-717-986-7605, or write to:

CUSTOMER SERVICE (38-35)
TYCO ELECTRONICS CORPORATION
P.O. BOX 3608
HARRISBURG, PA 17105-3608

For tool repair service, please contact an Tyco Electronics Representative at 1-800-526-5136.

8. REVISION SUMMARY

- Updated document to corporate requirements
- Changed item 6 part number in table in Figure 7

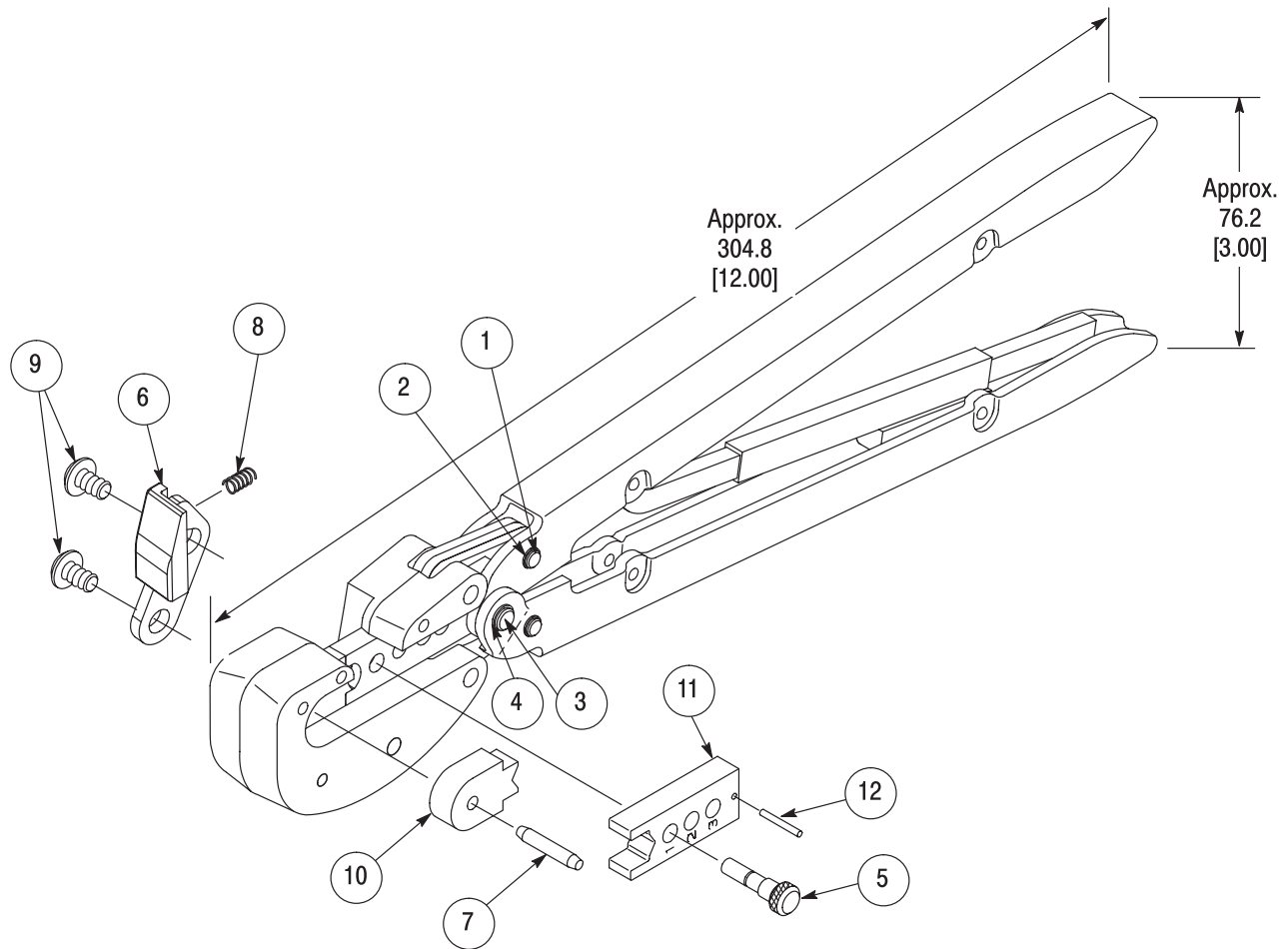

ITEM NO.	DESCRIPTION	QTY PER TOOL	PIDG STRATO-THERM TERMINAL CRIMPING TOOL REPLACEMENT PARTS						
			576778	576779	576780	576781	576782	576783	576784
1	PIN, Retaining	2	300388	300388	300388	300388	300388	300388	300388
2	RING, Retaining	4	525108	525108	525108	525108	525108	525108	525108
3	PIN, Retaining	1	300389	300389	300389	300389	300389	300389	300389
4	RING, Retaining	2	21045-6	21045-6	21045-6	21045-6	21045-6	21045-6	21045-6
5	PIN, Adjustment	1	1752891-1	1752891-1	1752891-1	1752891-1	1752891-1	1752891-1	1752891-1
6	LOCATOR, Stop	1	1901238-1	1901238-1	1901238-2	1901238-2	1901238-2	1901238-2	1901238-3
7	PIN	1	5-21028-7	5-21028-7	5-21028-7	5-21028-7	5-21028-7	5-21028-7	5-21028-7
8	SPRING	1	7-59683-6	7-59683-6	7-59683-6	7-59683-6	7-59683-6	7-59683-6	7-59683-6
9	SCREW	2	59580-6	59580-6	59580-6	59580-6	59580-6	59580-6	59580-6
10	STATIONARY DIE, Insulation	1	576788	576788-1	576788-2	576788-2	576788-3	576788-3	576788-4
11	MOVING DIE, Insulation	1	576785	576785-1	576785-2	576785-2	576785-3	576785-3	576785-4
12	PIN	1	21028-4	21028-4	21028-4	21028-4	21028-4	21028-4	21028-4

Figure 7