

PROPER USE GUIDELINES

Cumulative Trauma Disorders can result from the prolonged use of manually powered hand tools. Hand tools are intended for occasional use and low volume applications. A wide selection of powered application equipment for extended-use, production operations may be available.

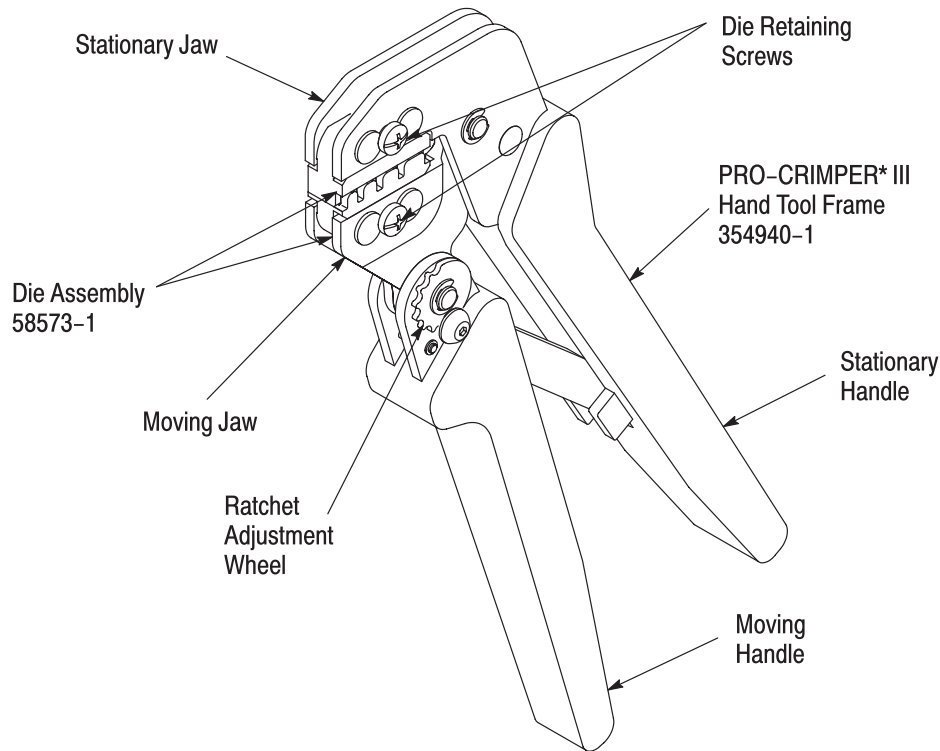

Figure 1

1. INTRODUCTION

This instruction sheet covers the use of PRO-CRIMPER III Hand Tool 58573-1 with Crimping Die Assembly 58573-2, which is used to apply the standard and moisture resistant spare wire caps listed in Figure 2. The die assembly is designed to be used in PRO-CRIMPER III Hand Tool Frame 354940-1 (shown in Figure 1). For instructions concerning the operation of the hand tool, refer to Instruction Sheet 408-9930, which is supplied with the tool.

The tool features a tool frame with a stationary jaw and handle, a moving jaw, a moving handle, and an adjustable ratchet that ensures full contact crimping.

NOTE

Measurements are in millimeters [followed by inch equivalents in brackets].

Reasons for reissue of this document are provided in Section 8, REVISION SUMMARY.

2. DESCRIPTION (Figure 1)

Each die assembly consists of an indenter die and an anvil die. When closed, the dies form four crimping chambers, which coincide with the four sizes of spare wire caps. Die retaining screws are used to secure the dies in the tool frame.

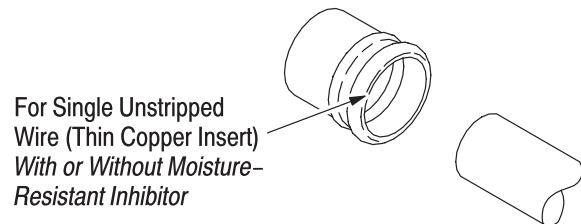

WIRE INSUL. DIA. RANGE	SPARE WIRE CAP No's		CAP COLOR CODE	TOOL COLOR CODE DOT
	STANDARD	MOISTURE RESISTANT		
1.22 - 1.91 [.048 - .075]	324484	324693	WHITE	WHITE
2.03 - 2.92 [.080 - .115]	324485	324694	RED	RED
3.05 - 3.68 [.120 - .145]	324486	324695	BLUE	BLUE
3.81 - 5.33 [.150 - .210]	324487	324696	YELLOW	YELLOW

Figure 2

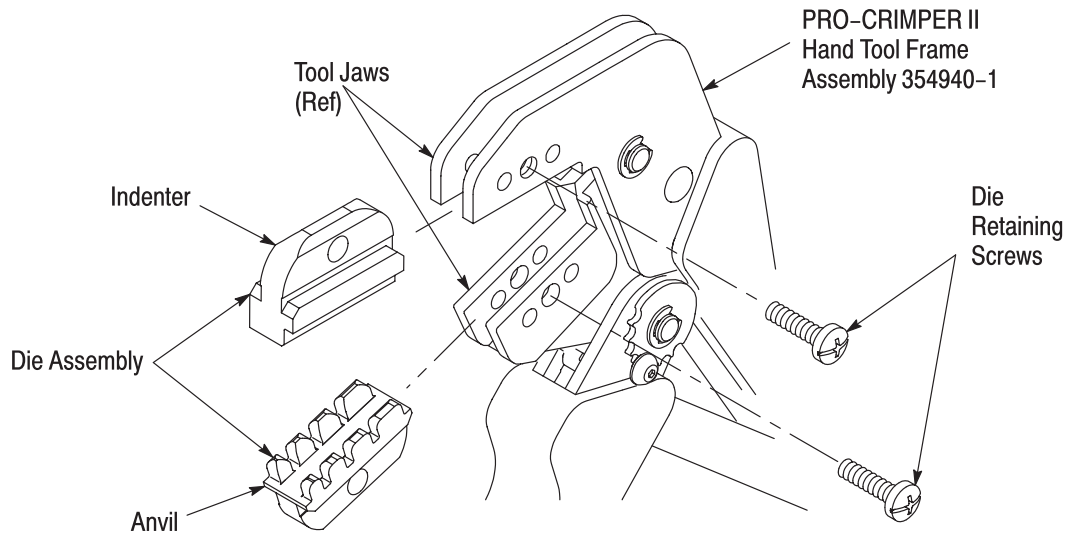

Figure 3

3. DIE INSTALLATION

1. Close the tool handles until the ratchet releases, then allow the handles to open fully.
2. Insert the dies into the tool jaws as shown in Figure 3, and align the die retaining holes in each die with the associated holes in the tool.
3. Thread, but do not tighten, the die retaining screws into the holes.
4. Carefully close the tool handles, making sure that the dies align properly.
5. Tighten the die retaining screws.

4. CRIMPING PROCEDURE

1. Refer to Figure 2, and select a cap of the correct size for the insulation diameter of the wire being used.
2. Identify the color code of the cap, and insert the cap into the crimping chamber with the same color code. Be sure that the cap is fully inserted.
3. Begin closing the tool handles until the cap is held firmly in place. Do NOT deform the cap.

4. Insert the unstripped wire completely into the cap.

NOTE

When bottoming the wire in a moisture-resistant cap, greater insertion force must be exerted on the wire to displace the inhibitor present in the cap.

5. Close the tool handles until the ratchet releases.
6. Allow the tool handles to open FULLY and remove the crimped cap from the crimping chamber by turning the cap and wire 1/4 turn while pulling lightly on the wire.

CAUTION

Damaged products may not be used. If a damaged product is evident, it must be replaced.

5. CRIMP INSPECTION (Figure 4)

Inspect the crimped spare wire cap. The crimp should be near the center of the insert in the cap, and the wire should be bottomed in the cap.

Double check that the correct cap was used for the wire's insulation diameter, and make sure that the correct crimping chamber was used.

If the cap fails inspection, remove the cap by cutting the wire, then apply a new cap to the wire by carefully following the above procedure.

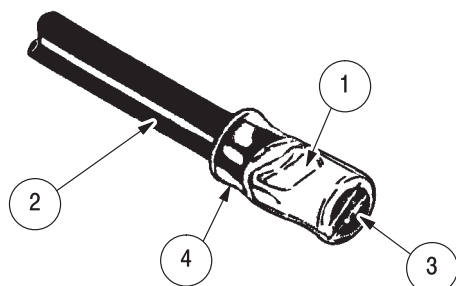
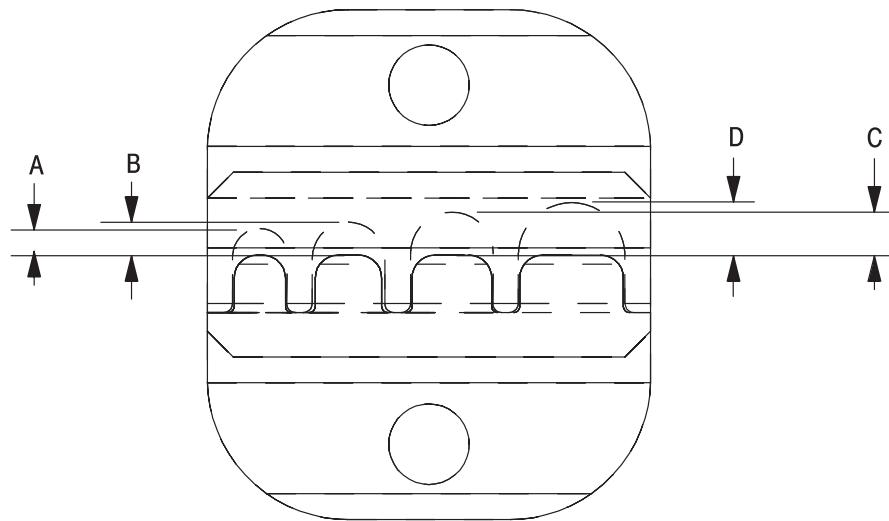

Figure 4

- ① Crimp near center of insert. (Cap was fully bottomed in die closure.)
- ② Correct wire insulation diameter for cap being used.
- ③ Wire bottomed in cap.
- ④ Cap insulation color matches die closure color dot code.



HAND TOOL AND DIE ASSEMBLY PART NUMBERS	DIE OPENING ± 0.10 [.004]			
	A	B	C	D
58573-1 58573-2	1.83 [.072]	2.26 [.089]	2.95 [.116]	3.61 [.142]

Figure 5

6. MAINTENANCE AND INSPECTION

6.1. Maintenance

1. Remove dust, moisture, and other contaminants with a clean, soft brush, or a clean, soft, lint-free cloth. Do NOT use any objects that could damage the dies or tool.
2. Make sure that the proper die retaining screws are properly secured.
3. When the dies are not in use, store them in a clean, dry area. When the tool is not in use, store it with the handles closed to prevent objects from being lodged within the jaws.

6.2. Inspection

1. Remove all lubrication and accumulated film from the dies by immersing the dies in a suitable commercial degreaser.
2. Make certain that all die retaining screws and die components are properly secured.
3. Inspect the crimping surfaces for flattened, chipped, worn, or cracked areas. If damage is evident, the dies must be replaced. Refer to Section 7, REPLACEMENT.

6.3. Measuring Die Opening

The die assembly will perform correctly as long as: (1) the product specified is correct for the application,

(2) the specific die assembly is used, (3) the die assembly has been measured to ensure that the openings are correct, and (4) the die assembly bottoms.

Figure 5 provides information on die opening sizes.

6.4. Ratchet Adjustment (Figure 6)

The tool frame assembly ratchet mechanism features an adjustment wheel with numbered settings. If the crimp height is not acceptable, adjust the ratchet as follows:

1. Remove the lockscrew from the ratchet adjustment wheel.
2. With a screwdriver, adjust the ratchet wheel from the opposite side of the tool.
3. Observe the ratchet adjustment wheel. If a tighter crimp is required, rotate the adjustment wheel COUNTERCLOCKWISE to a higher-numbered setting. If a looser crimp is required, rotate the adjustment wheel CLOCKWISE to a lower-numbered setting.
4. Replace the lockscrew.
5. Make a sample crimp and measure the crimp height. If the crimp height is acceptable, secure the lockscrew. If the dimension is unacceptable, remove lockscrew and continue to adjust the ratchet, and again measure a sample crimp.

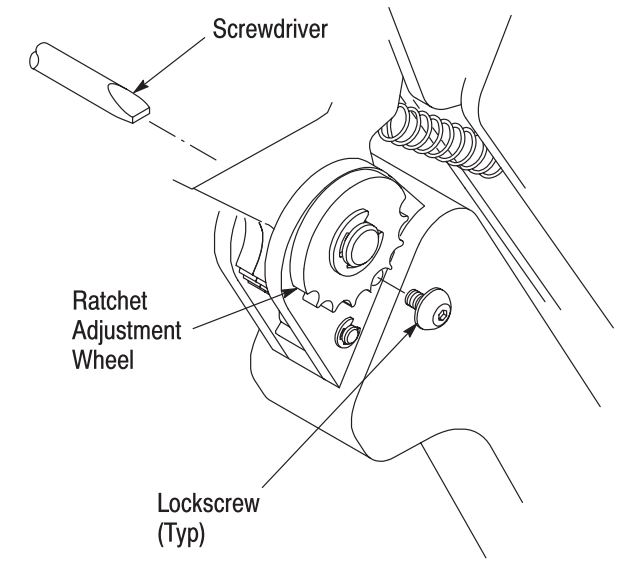

Figure 6

7. REPLACEMENT

Order replacements through your Tyco Electronics Representative, or call 1-800-526-5142, or send a facsimile of your purchase order to 1-717-986-7605, or write to:

CUSTOMER SERVICE (38-35)
TYCO ELECTRONICS CORPORATION
P.O. BOX 3608
HARRISBURG, PA 17105-3608

8. REVISION SUMMARY

Since the previous release of this document, the following changes have been made:

Per EC 0990-0465-05:

- Updated document to corporate requirements
- Added die set 58573-2 to title, Introduction, and table in Figure 5
- Changed lockscrew in Figures 1, 2, and 6
- Changed PRO-CRIMPER II to PRO-CRIMPER III in all instances