

OPERATION MANUAL  
for  
YRS HAND TOOL  
(for strip terminals)

TE-4052

J. S. T.

The YRS series hand crimp tools are used to crimp strip terminals to wire in the recommended wire range for each terminal. Each crimper has two crimping sections. Please refer to the chart to find which model should be used.

1. Part names

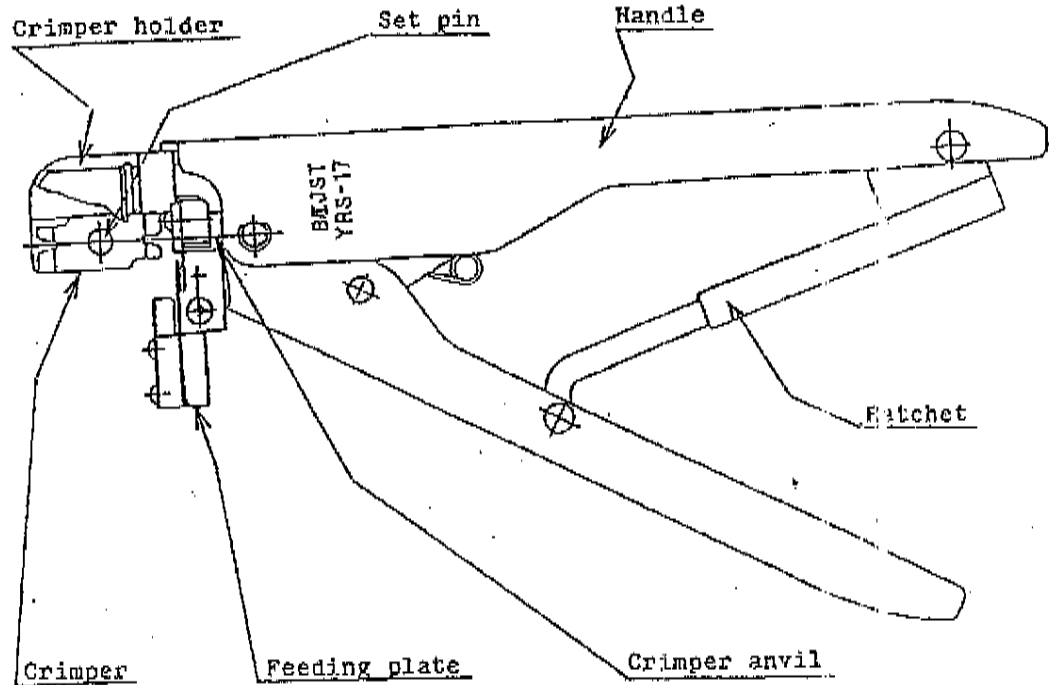

Fig. 1

2. Preparation for Operation

(1) Cut strip terminals for your easy operation. (Or leave the terminal reel as it is, if you prefer.) Cut the first two or three terminals off the strip carrier per Fig. 2.

(2) Strip a wire of the insulation per Fig. 3.

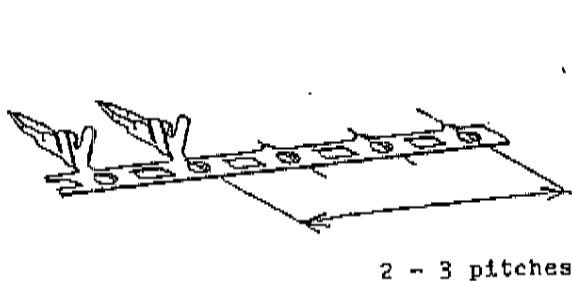

Fig. 2

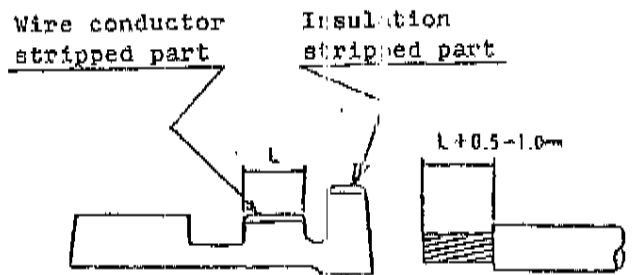

Fig. 3

### 3. Crimping operation

- (1) Squeeze handles until ratchet releases and handles open.
- (2) Make sure of the applicable wire range which is stamped on the crimper, so that the crimper is installed correctly in the main unit.
- (3) Insert the strip carrier of terminals between the ① feeding plate and ② pressure plate. Position a terminal to be held under the ③ terminal guide (A) and ④ terminal guide (B) per Fig. 5. Feed terminals until the first terminal is aligned with the crimper and the crimper anvil. (See Fig. 6.)
- (4) Squeeze handles gently until the terminal is held by the crimper and the crimper anvil. At this time, do not crimp(deform) the terminal.  
Now insert a wire into the terminal until the wire is stopped by the ③ terminal guide (A).
- (5) Squeeze handles completely, holding the wire to keep it in place, until ratchet releases and handles open.
- (6) Remove the crimped terminal and check if the wire is crimped correctly.

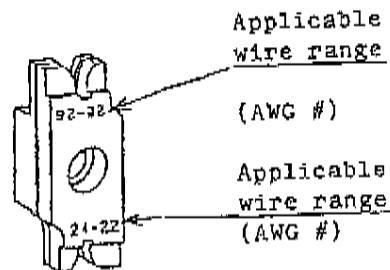

Fig. 4

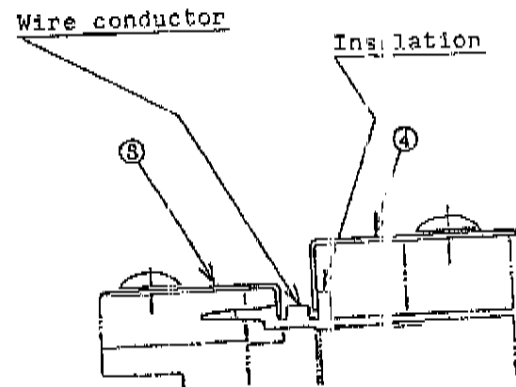

Fig. 5

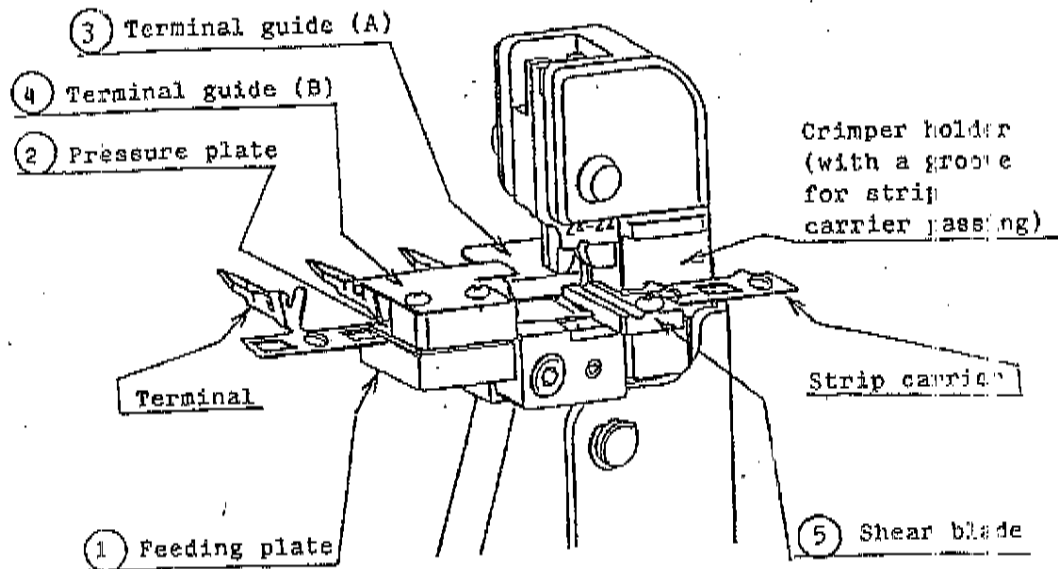

Fig. 6

#### 4. Suggestions

- (1) Make sure correct tool and terminal are used for each wire.
- (2) Ratchet does not allow handles to open until crimping is completed. Do not force handles open during crimping process.
- (3) When the crimper is re-set, make sure of correct positioning. (Its stamped surface must face the shear blade.)
- (4) When feeding terminals, make sure the strip carrier is under the shear blade and through the groove for strip carrier in the crimper holder.
- (5) Periodically oil all parts and pins of the tool, and store in paper or cloth after coating oil on the whole surface when not in use.
- (6) Do not use tools with rust, scratches, or foreign matter on the surfaces of crimper or crimper anvil.
- (7) Do not use tools if broken or damaged in any way, or some parts missing. Contact JST. Do not attempt to repair or adjust them.

8) Before operation, make sure that :-

- a. Crimping section is clean without rust, scratches or foreign matters on it.
- b. The ratchet operates properly after crimper and crimper anvil touches each other.
- c. A wire is crimped correctly. (appearance, crimp height, etc.)

Note : Tools are subject to change without prior notice.

5. Selection of proper combination (terminal-wire-tool)

Tool model no.	Applicable terminal model no.	Applicable wire (UL1007 AWG)
YRS-11	SXH-001T-P0.6	#28 - #22
" -12A	SYM-001T-0.6	" - "
" -12B	SHF-001T-0.8S	" - "
" -17	SBN-001T-1.0	#28 - #24
" -19	SCN-001T-1.0	#28 - #22
" -19B	SCN-001T-1.0B	" - "
" -22	SAN-002T-0.8	#30 - #24
" -24	SPH-002T-P0.5	" - "
" -24S	SPH-002T-P0.5S	" - "
" -26	SEH-001T-P0.6	#28 - #22

# OPERATION MANUAL FOR YRS SERIES HAND CRIMP TOOL

## Preface

1. The YRS series hand tool crimps smaller sized chain (with open barrel) terminals, and was designed to be used for small preproduction lots, samples and repairs.  
An upper die has two crimping positions. Set it depending on the applicable wire size for each position.  
This tool can crimp side-feeding terminals only.
2. As the crimp height of the tool is not adjustable, the applicable wires are limited. So some tools come with two different upper dies.

## Precautions

- (1) Make sure the correct combination of wire, terminal, and tool is used.
- (2) Because the tool has a ratchet, the handles will not open until the terminal is completely crimped. Do not forcibly open the handles while crimping. If you need to open the handles because, for example, a terminal is positioned incorrectly, or a foreign body is stuck in the crimp tool, remove the adjustment pin and upper die, and squeeze handles until the ratchet is released.
- (3) Check the following items before use:
  - a. Make sure there are no scratches, rust, or dust on the crimping dies.
  - b. When crimping a terminal to a wire, does the ratchet operate normally after the crimping dies are completely closed?
  - c. Are both the tensile strength and appearance adequate?
- (4) Do not use the crimp tool for purposes other than crimping.
- (5) Periodically add oil to the moving parts and the pins of the crimping tool. If you don't plan on using the tool for a long time, apply oil to the entire body of the tool, and put it in a rust preventive bag, or wrap it with a oiled cloth before storing.
- (6) Consult with JST if the tool breaks or needs to be repaired.

2

Insert the strip carrier of the chain terminals in between the ① terminal guide and ② guide plate. Insulation barrels should be positioned in the groove of the ② guide plate. Feed the chain terminals until the insulation barrel of the first terminal comes to the center of the crimping position, while holding the strip carrier by fingers, lightly pressing it forward notch by notch. Refer to Fig. 2 and

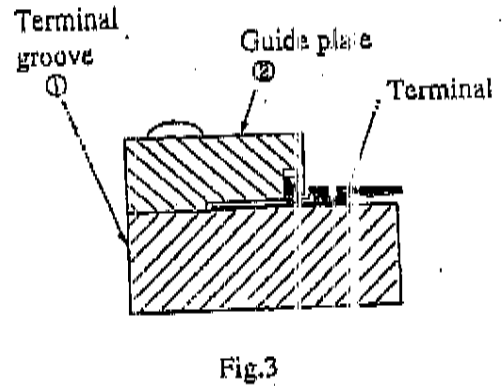
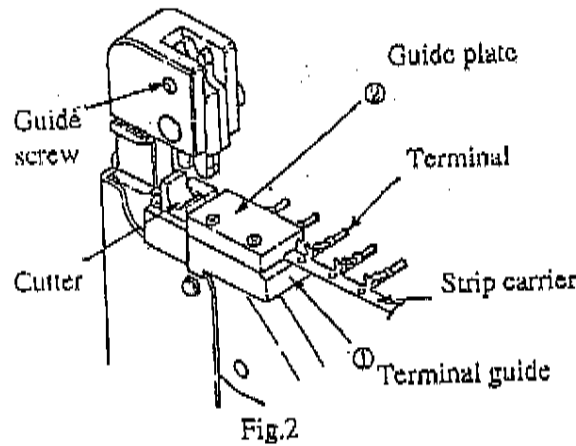

3

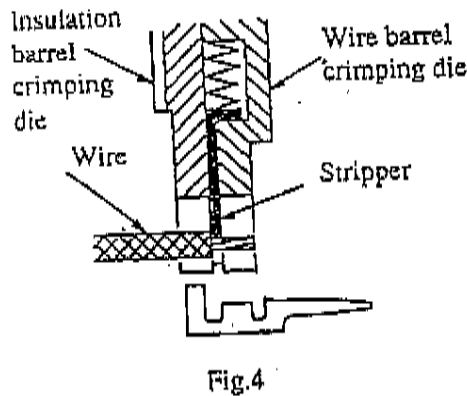

Grip the handles so the terminal is just held in the dies. Do not put too much pressure on the terminal at this point. If you deform it, you may not be able to insert the wire. Position a stripped wire so that the insulation edge is lightly pressed against the stripper. See Fig. 4 in the left.

4

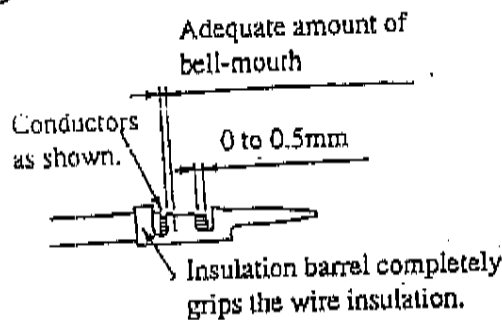

There shall be no unusual burrs.

Fig.5

- (1) Squeeze the handles to crimp the terminal while holding the wire to keep it in the correct position until the ratchet releases.
- (2) Remove the terminal and make a visual inspection. See Fig. 5.

# 1. Names of each part

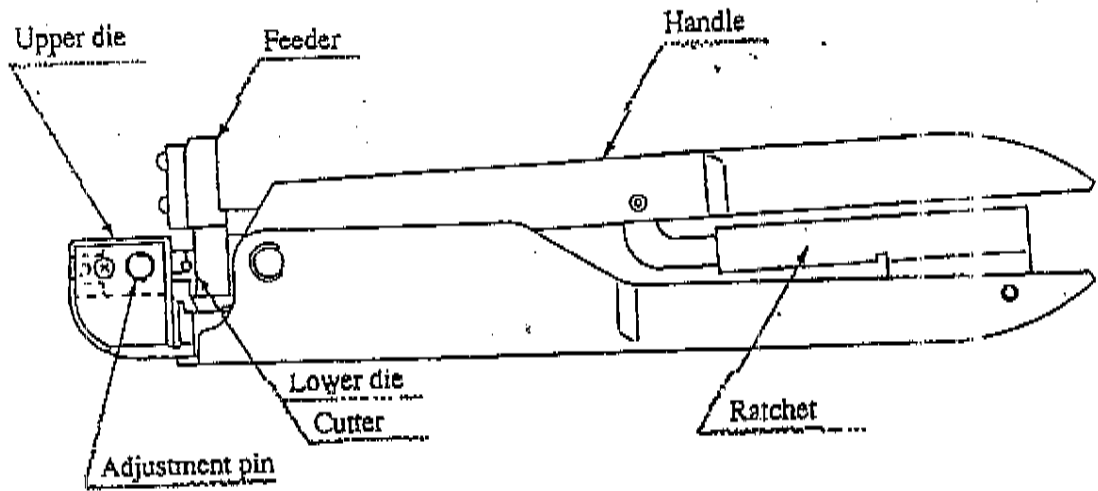

# 2. Crimping Operation

1

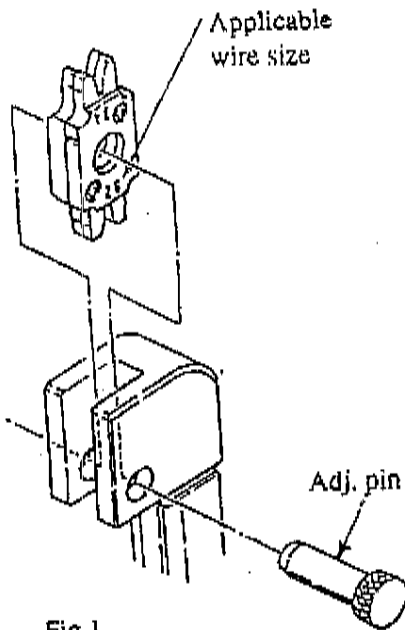

Fig.1

- (1) Squeeze the handles until the dies are completely closed. The ratchet will then release and the handles will open.
- (2) Check the marking on the upper die. The applicable wire size is shown there. Select the correct position depending on the wire you will use. Then correctly set the upper die, as shown in Fig. 1.

Position the upper die so that the tail of the guide screw is inserted in the guide groove of the upper die (on the insulation barrel side). < Refer to Fig. 2.> The die cannot be set when oppositely mounted.



## **Caution**

- (1) *Squeezing the handles ...  
Do not squeeze the handles excessively. Otherwise, the dies may be broken. The tools are factory adjusted so that the ratchet may best function with the load ranging 20 to 30 kgf. (Varies somewhat depending on the applicable terminal.)*
  
- (2) *Wire setting ...  
When the handles are squeezed, the upper die is lowered. As the wire is set on the upper die, care should be taken so that the wire does not come off the stripper.*

In line with a policy of continual product development, JST reserves the right to change the specifications of the goods described in this catalogue at any time and without prior notice. Contact JST for details.