

Model 6358
48" (1,2m) Retractable Sheath Modular Test Leads
Qty 2 - 1 Red, 1 Black

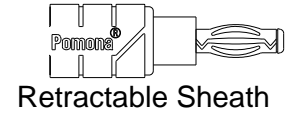

3564 3562
ø.19" ø.14"
(4,8mm) (3,6mm)

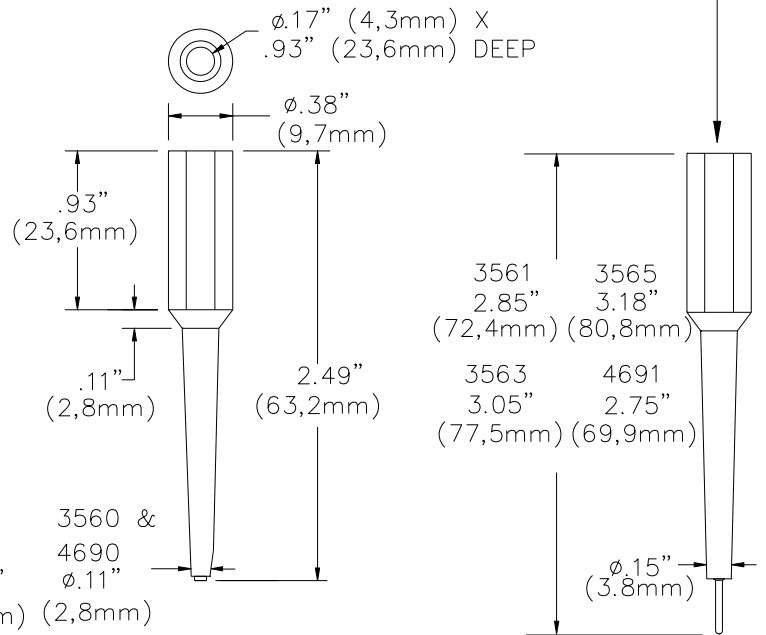

FEATURES:

- ✓ 18 piece kit includes one red and one black set of each pin & socket size along with a set of 48" (1,2m) red and black test leads.
- ✓ Test adapters are ideal for rapid testing of the hard-to-get at contacts of multi-pin/socket connectors.
- ✓ Round pins and socket adapters.
- ✓ Flexible tip allows testing of adjacent contacts.
- ✓ Full insulation protects against shorting or contact damage.
- ✓ Test leads feature high strand count silicone wire for extreme flexibility and high temperature resistance.
- ✓ Model 4690 also fits 0.025in (0.63mm) sq. pins.

Model	Contact Size	Type	Current
4690	22 AWG .030" (.76mm)	Socket	5 Amps
4691		Pin	
3560	20 AWG .040" (1.02mm)	Socket	7.5 Amps
3561		Pin	
3562	16 AWG .063" (1.60mm)	Socket	13 Amps
3563		Pin	
3564	12 AWG .093" (2.36mm)	Socket	24 Amps
3565		Pin	

Voltage Rating:

Hands free testing in controlled voltage environments:
1000 Vrms Max. *For CE compliance:* not intended for hand-held use at voltages above 33 Vrms/70 Vdc.

All dimensions are in inches. Tolerances (except noted): .xx = ±.02" (.51 mm), .xxx = ±.005" (.127 mm).

All specifications are to the latest revisions. Specifications are subject to change without notice.

Registered trademarks are the property of their respective companies.

Sales: 800-490-2361 Fax: 888-403-3360 Technical Support: 800-241-2060 (technicalsupport@pomonatest.com)
For "Where to Buy" information, visit the Pomona web site at www.pomonaelectronics.com

MATERIALS:

Models: 3560, 3562, 3564 & 4690

Insulation: Polyvinyl chloride (PVC)

Banana Jack Body (upper connector)

Material: Brass.

Finish: Bright Tin plated

Socket (lower connector):

Material: Copper Alloy

Finish: Gold over copper plate

Models: 3561, 3563, 3565 & 4691

Insulation: Polyvinyl chloride (PVC).

Banana Jack Body (upper connector)

Material: Brass.

Finish: Bright Tin plated

Pin (lower connector):

Material: Brass

Finish: Gold plated over electroless nickel.

RATINGS (*Modes: 3560, 3562, 3564, 4690, 3561, 3563, 3565 & 4691 only*)

Voltage: Hands free testing in controlled voltage environments: 2500 Vrms Max. *For CE compliance: not intended for hand-held use at voltage above 33 Vrms/70 Vdc.*

Temperature: +131F (+55C) Max.

Model: 6358 Test Leads (male to male)

Multi-Stranded Wire: 18 AWG Silicone, Color: One Black, One Red

Banana Plug: Insulation: Polypropylene, Color: One Black, One Red Retractable Sheath Banana Plug:

Plug Body: Brass, Nickel Plated

Banana Spring: Beryllium Copper, Nickel Plated

Compression Spring: Stainless Steel

Tip: Nylon, Color Matches Color of Wire

Insulation: Polypropylene Molded to the Plug and Wire. Color Matches Color of Wire.

Wire: 18 AWG, Stranding 65 x 36 t.c., Silicone Insulated, .144 (3,66mm) O.D.

RATINGS (6358 only):

Conforms to IEC 1010, Cat. III, P2

Operating Voltage: 1000V

Operating Temperature: +131F (+55C) Max.

Current: 10 Amperes

ORDERING INFORMATION:

Model: **6481**

Kit contains one red and one black adapter of each model; 3560, 3561, 3562, 3563, 3564, 3565, 4690, 4691 and one set of Model 6358 test leads.

All dimensions are in inches. Tolerances (except noted): .xx = ±.02" (.51 mm), .xxx = ±.005" (.127 mm).

All specifications are to the latest revisions. Specifications are subject to change without notice.

Registered trademarks are the property of their respective companies.

Sales: 800-490-2361 Fax: 888-403-3360 Technical Support: 800-241-2060 (technicalsupport@pomonatest.com)

For "Where to Buy" information, visit the Pomona web site at www.pomonaelectronics.com

Pomona[®]

The items included with this product are certified to meet IEC 1010-2-031 safety requirements.

Les éléments inclus avec ce produit sont certifiés pour répondre à des exigences de sûreté du IEC 1010-2-031.

Los items incluidos con este producto se certifican para resolver requisitos de seguridad del IEC 1010-2-031.

– Only IEC 1010 type shrouded test plugs should be used with IEC 1010 type jacks. NEVER INSERT A PROBE TIP WITH BANANA SPRING INTO A TEST ACCESSORY JACK THAT WILL BE USED AS A HAND HELD PROBING DEVICE

–Seuls les vérificateurs de tension renforcés de type IEC 1010 devraient être utilisés avec des jacks de type IEC 1010. NE JAMAIS INSERER DE BOUT DE SONDE AVEC RESSORT BANANE DANS UN JACK D'ESSAI D'ACCESSOIRES QUI SERA UTILISE COMME DISPOSITIF DE SONDAGE A MAIN.

–Se deben usar sólo tapones de prueba reforzados del tipo IEC 1010 con receptáculos de tipo IEC 1010. NUNCA INTRODUZCA UNA CLAVIJA CON UN MUELLE TIPO BANANA EN UN RECEPTACULO DE PRUEBA QUE A SU VEZ SE USE COMO APARATO DE PRUEBA MANUAL.

12

Both Direct and Alternating Current.
Courant Continu et Alternatif.
Corriente Directa y Alterna.



Caution ! Refer to Accompanying Documents.
Attention ! Se Reporter aux Documents joints.
; Peligro! Consulte los Documentos Adjuntos.



Double Insulation or Reinforced Insulation.
Isolation Double ou Isolation Renforcée.
Aislamiento Doble o Aislamiento Reforzado.



Caution ! Risk of Electric Shock.
Attention ! Risque de Choc Électrique.
; Peligro! Riesgo de Sacudida Eléctrica.

CAT

Overtension Category I, II, III or IV.
Surtension Catégorie I, II, III ou IV.
Sobretensión de Categoría I, II III o IV.

Pomona Electronics



PO Box 9090, Everett, WA 98206-9090 TEL: 800-490-2361

All dimensions are in inches. Tolerances (except noted): .xx = ±.02" (.51 mm), .xxx = ±.005" (.127 mm).

All specifications are to the latest revisions. Specifications are subject to change without notice.

Registered trademarks are the property of their respective companies.

Sales: 800-490-2361 Fax: 888-403-3360 Technical Support: 800-241-2060 (technicalsupport@pomonatest.com)
For "Where to Buy" information, visit the Pomona web site at www.pomonaelectronics.com