

NOTES: UNLESS OTHERWISE SPECIFIED

- CONSTRUCTION: HOUSING & PLUNGER: MOLDED NYLON TYPE 6.6. AVAILABLE IN TEN COLORS. CONTACT BLADE: BERYLLIUM COPPER PER QQ-C-533. GOLD PLATED PER MIL-G-45204 B TYPE 1 0.00001" [0.000254] THICK MINIMUM. SPRING: STAINLESS STEEL TYPE 302.

- PERFORMANCE: MAXIMUM CURRENT: 5.9 AMPS WITH A 77° TEMPERATURE RISE. MAXIMUM VOLTAGE: 5.4 KV MAXIMUM TEMPERATURE: 200°F (93°C)
- FEATURES: HOOK FITS COMPONENTS UP TO 0.040" [1.01]. FIELD SERVICEABLE.

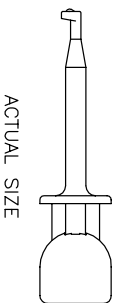
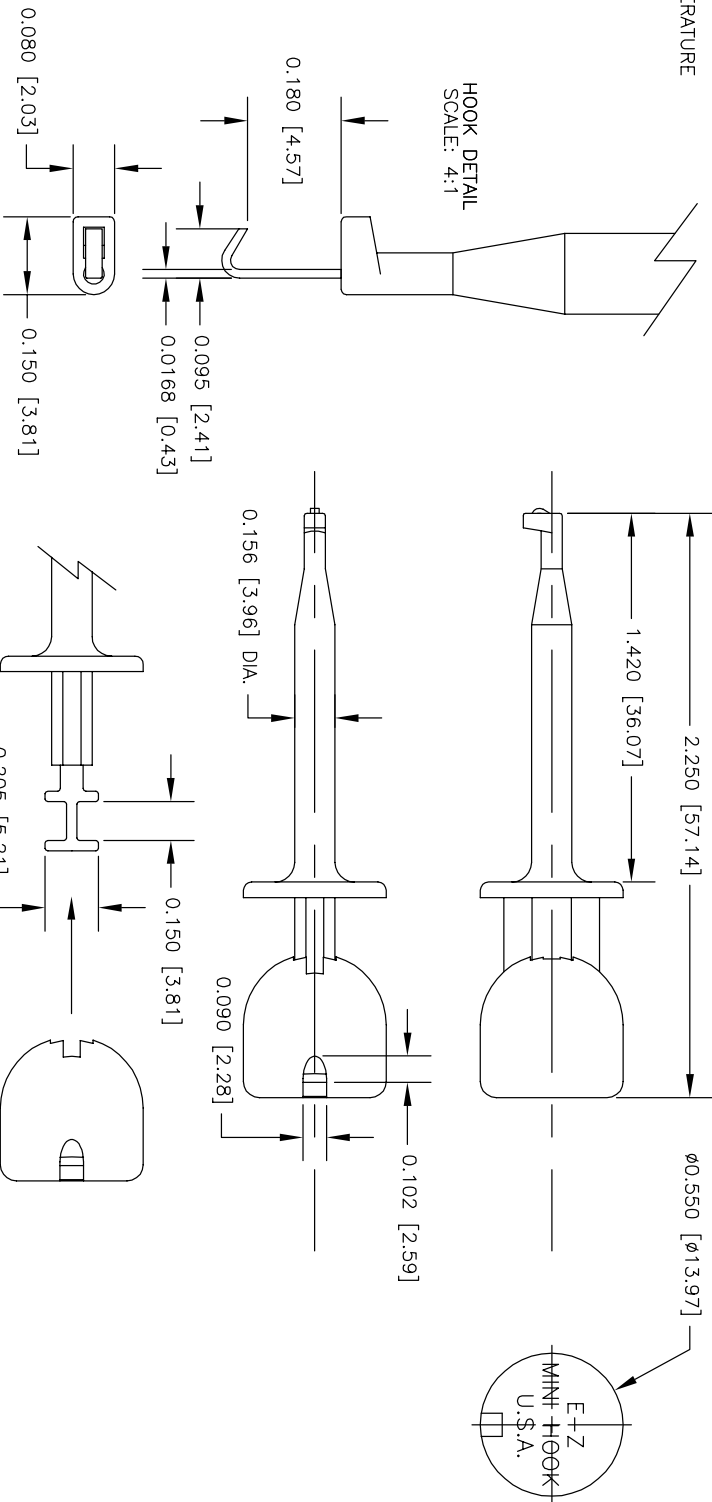

REVISIONS		DATE	APPROVED
LTR			

UNLESS OTHERWISE SPECIFIED DIMENSIONS ARE IN INCHES FRACTIONS DECIMALS ANGLES ° XXX + °		CONTRACT NO.		DESCRIPTION	
DO NOT SCALE DRAWING		APPROVALS	DATE	E-Z-HOOK® DIVISION OF TEKTEST INC. ARCADIA, CA 91006 U.S.A.	
MATERIAL SEE NOTE.		R.L.	6/09	E-Z-MINI-HOOK TEST CONNECTOR	
FINISH SEE NOTE.		APPROVED BY		SIZE	CODE IDENT NO. DRAWING NO.
NEXT ASSY USED ON				B	08505 X100W
APPLICATION				SCALE	
				2:1	

THE INFORMATION CONTAINED IN THIS DOCUMENT IS PROPRIETARY TO E-Z-HOOK. THE INFORMATION IS NOT TO BE REPRODUCED WITHOUT PERMISSION OF E-Z-HOOK, DIV. OF TEKTEST INC. MAXIMUM TESTED RATING IN HANDS-FREE CONTROLLED ENVIRONMENT. MAXIMUM RATING IS NOT TO BE USED CURRENTLY.