

FEATURES

- Easy to use
- Simple gain setting
- Solder jumper
- SMA/SMB outline
- Decoupled supply lines
- Undedicated 10-lead SOIC pad

APPLICATIONS

- Characterize the AD8220
- Interface the AD8220 with other evaluation tools
- Breadboard custom application circuits

GENERAL DESCRIPTION

The AD8220-EVAL offers users the option of evaluating the AD8220 by itself or within the context of an application. The evaluation board is arranged such that users can easily adjust the gain resistor and reference jumper. The board offers an SMA/SMB outline at the output. Users can add their own connector to interface the board with complementary tools such as an analog-to-digital converter (ADC) evaluation board, available from Analog Devices, Inc. Breadboard space has been integrated to promote experimentation with the AD8220. For example, active filters, line drivers, and converters can be placed on the breadboard space, extending the use of the evaluation board as a development tool.

Table 1. Factory Setting

Connection	Purpose
W1 is soldered	REF is tied to GND

QUICK START¹

Connect a ± 2.3 V to ± 15 V supply to $+V_S$ and $-V_S$. Drive the inputs with a signal. Measure the output on a multimeter or oscilloscope. The output voltage is the voltage measured between OUT and REF. The output can drive another device, such as an ADC.

¹ Assumes board is in default configuration; W1 is soldered.

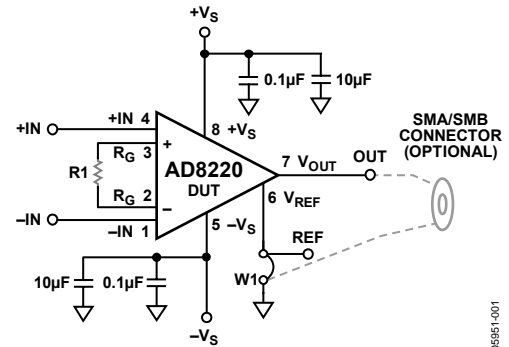

Figure 1. Evaluation Board Schematic

REFERENCE

The instrumentation amplifier's reference level can be set by driving the REF pin with a precision voltage reference or by using the solder jumper, W1. By default, W1 is soldered, shunting REF to GND. If a reference voltage other than ground is used, the solder must be removed from W1 before driving REF with the reference voltage, as shown in Figure 2.

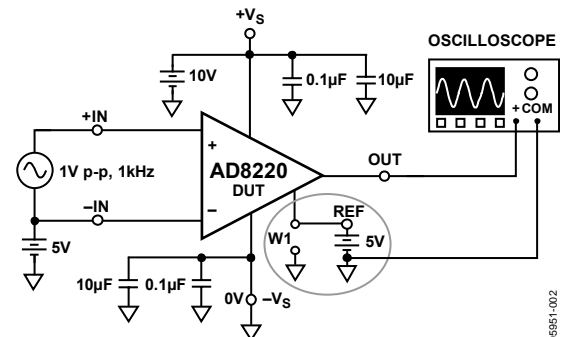

Figure 2. Using an External Voltage Source to Set the Reference Level (Circled)

Rev. 0

Information furnished by Analog Devices is believed to be accurate and reliable. However, no responsibility is assumed by Analog Devices for its use, nor for any infringements of patents or other rights of third parties that may result from its use. Specifications subject to change without notice. No license is granted by implication or otherwise under any patent or patent rights of Analog Devices. Trademarks and registered trademarks are the property of their respective owners.

AD8220-EVAL

INPUT

The AD8220 requires a small amount of current, I_B , for the input transistors to function properly. Inputs should not be left floating. If they are floating, such as when the inputs are connected to a transformer, thermocouple, or a pair of series capacitors, they should have a dc path to ground, as shown in Figure 4. In contrast to the circuit in Figure 3, which has a current path from the signal generator to the input, the circuit in Figure 4 has series capacitors, C1 and C2, between the signal generator and the input. The series capacitors prevent a dc current from flowing into the instrumentation amplifier's input transistors. Matched 10 k Ω resistors are used between the instrumentation amplifier's inputs and ground to provide the necessary current path. Resistors should be matched to reduce offset and CMRR error.

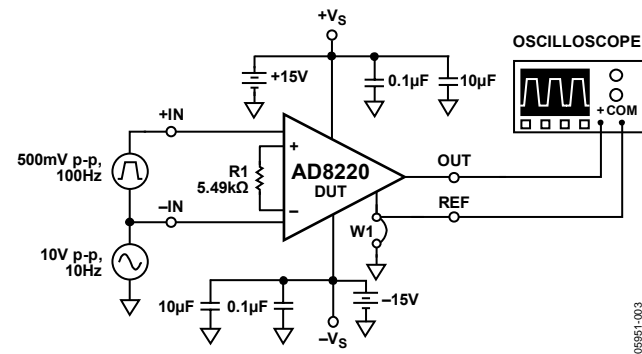

Figure 3. Example of Evaluation Board Configuration

OUTPUT

Output measurements should be made by measuring the voltage across OUT and REF, as shown in Figure 3 or Figure 4. If an external voltage reference is used, the output can be measured as shown in Figure 2. The evaluation board offers an SMA/SMB outline. By default, the output voltage measured, using an SMA/SMB connector, is with respect to GND.

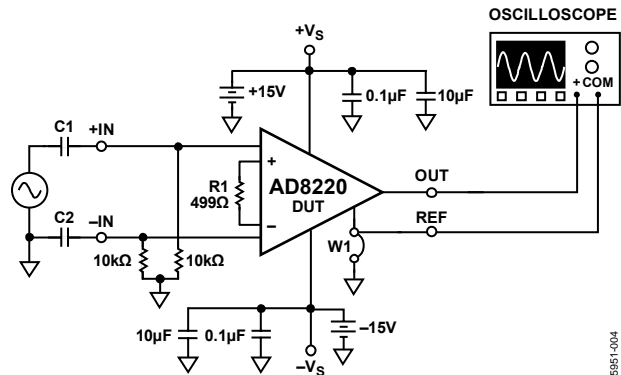

Figure 4. Providing a Bias Current Path to the Inputs of the AD8220

ESD CAUTION

ESD (electrostatic discharge) sensitive device. Electrostatic charges as high as 4000 V readily accumulate on the human body and test equipment and can discharge without detection. Although the AD8220-EVAL features proprietary ESD protection circuitry, permanent damage may occur on devices subjected to high energy electrostatic discharges. Therefore, proper ESD precautions are recommended to avoid performance degradation or loss of functionality.



ORDERING GUIDE

Model	Description
AD8220-EVAL	Evaluation Board