

# ASSR-4118 , ASSR-4119 and ASSR-4128

## Form A, Solid State Relay (Photo MOSFET)

(400V/0.10A/35Ω)



## Data Sheet



### Description

The ASSR-41XX Series consists of an AlGaAs infrared light-emitting diode (LED) input stage optically coupled to a high-voltage output detector circuit. The detector consists of a high-speed photovoltaic diode array and driver circuitry to switch on/off two discrete high voltage MOSFETs. The relay turns on (contact closes) with a minimum input current of 3mA through the input LED. The relay turns off (contact opens) with an input voltage of 0.8V or less.

The single channel configurations, ASSR-4118 and ASSR-4119, are equivalent to 1 Form A Electromechanical Relays (EMR), and the dual channel configuration, ASSR-4128, is equivalent to 2 Form A EMR. They are available in 4-pin SO, 6-pin DIP, 8-pin DIP and Gull Wing Surface Mount for DIP packages. ASSR-4119 enables AC/DC and DC-only output connections. For DC-only connection, the output current,  $I_o$ , increases to 0.2A and the on-resistance,  $R(ON)$  reduces to 10Ω.

### Applications

- Telecommunication Switching
- Data Communications
- Industrial Controls
- Medical
- Security
- EMR / Reed Relay Replacement

### Features

- Compact Solid-State Bi-directional Signal Switch
- Single and Dual Channel Normally-off Single-Pole-Single-Throw (SPST) Relay
- 400V Output Withstand Voltage
- 0.1A or 0.2A Current Rating (See Schematic for ASSR-4119 Connection A and B)
- Low Input Current: CMOS Compatibility
- Low On-Resistance: 8Ω Typical for DC-only, 25Ω Typical for AC/DC
- High Input-to-Output Insulation Voltage (Safety and Regulatory Approvals Pending)
  - 3750 Vrms for 1 min per UL1577
  - CSA Component Acceptance

### Functional Diagram

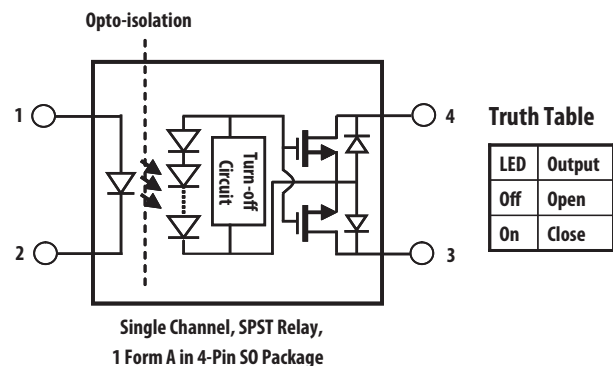

**CAUTION:** It is advised that normal static precautions be taken in handling and assembly of this component to prevent damage and/or degradation which may be induced by ESD.

## Ordering Information

ASSR-xxxx is UL Recognized with 3750 Vrms for 1 minute per UL1577 and is approved under CSA Component Acceptance Notice #5, File CA 88324.

Part number	Option					
	RoHS Compliant	Package	Surface Mount	Gull Wing	Tape & Reel	Quantity
ASSR-4118	-003E	SO-4	X			100 units per tube
	-503E		X		X	1500 units per reel
ASSR-4119	-001E	300mil DIP-6				50 units per tube
	-301E		X	X		50 units per tube
	-501E		X	X	X	1000 units per reel
ASSR-4128	-002E	300 mil DIP-8				50 units per tube
	-302E		X	X		50 units per tube
	-502E		X	X	X	1000 units per reel

To order, choose a part number from the part number column and combine with the desired option from the option column to form an order entry.

Example 1:

ASSR-4119-501E to order product of 300mil DIP-6 Gull Wing Surface Mount package in Tape and Reel packaging and RoHS Compliant.

Example 2:

ASSR-4128-002E to order product of 300mil DIP-8 package in tube packaging and RoHS Compliant.

Option datasheets are available. Contact your Avago sales representative or authorized distributor for information.

## System Schematics

### ASSR-4118

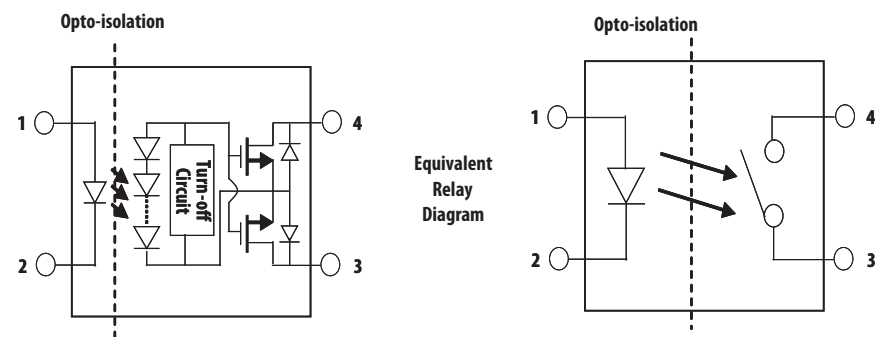

## System Schematics (Continued)

### ASSR-4119 Connection A

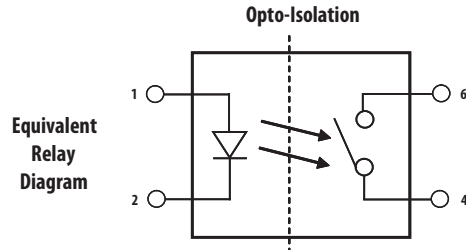
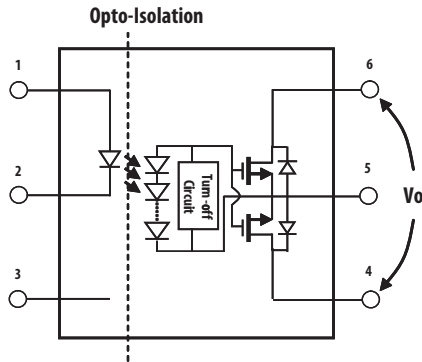

### ASSR-4119 Connection B

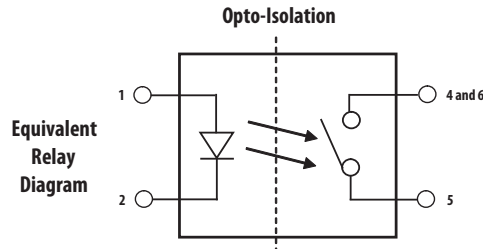
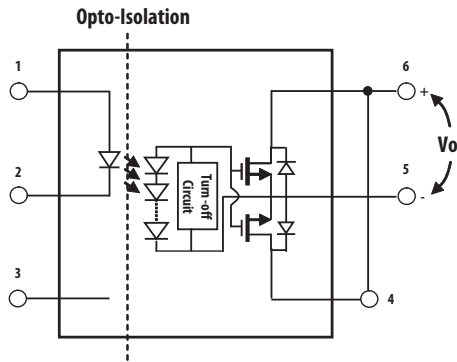

### ASSR-4128

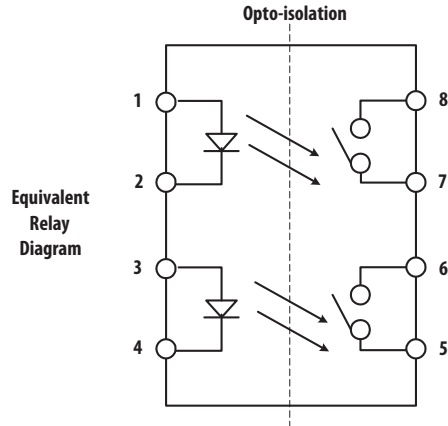
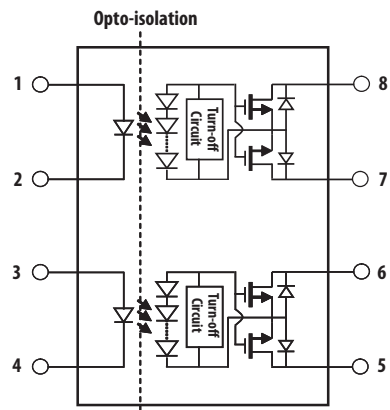

## Package Outline Drawings

### ASSR-4118 4-Pin Small Outline Package

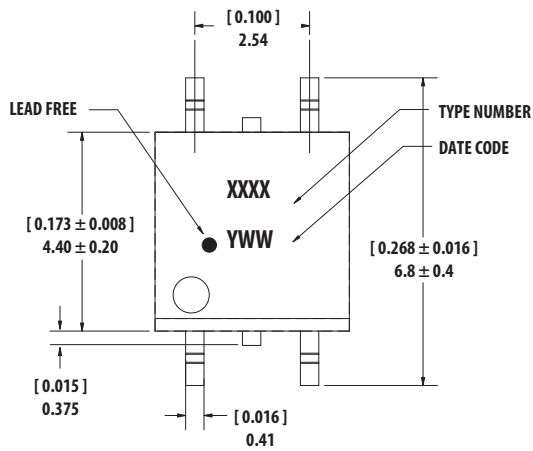

#### LAND PATTERN RECOMMENDATION

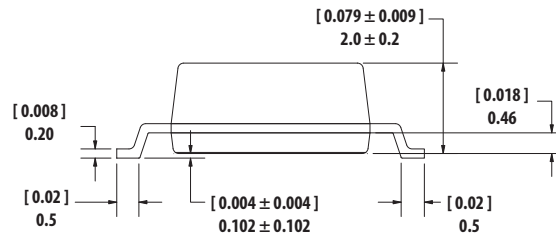
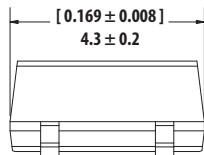
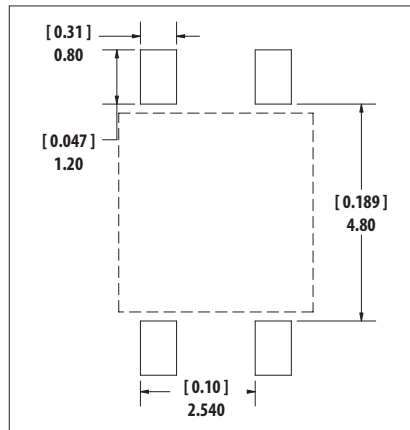

DIMENSIONS IN MILLIMETERS AND [INCHES]  
OPTION NUMBER 500 AND UL RECOGNITION NOT MARKED

### ASSR-4119 6-Pin DIP Package

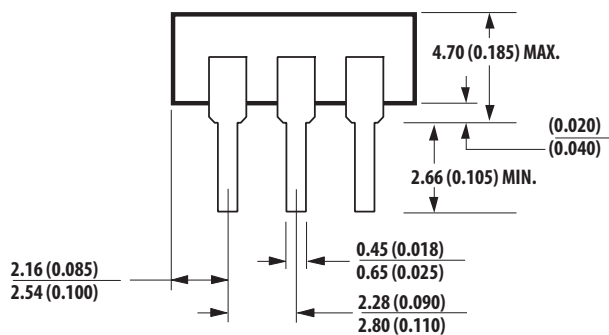
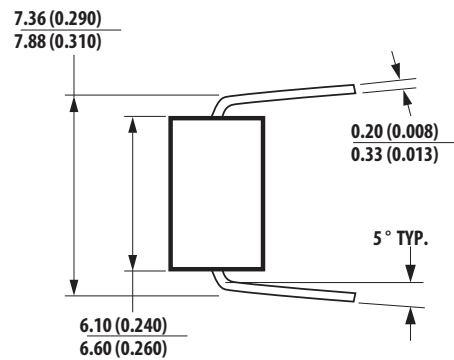
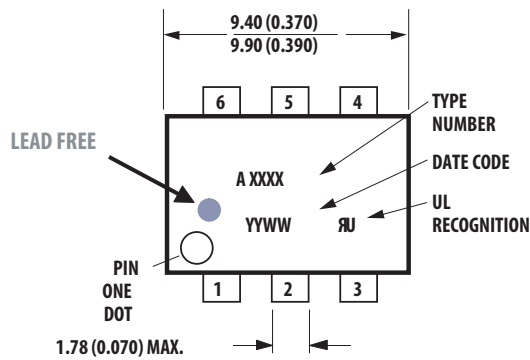

DIMENSIONS IN MILLIMETERS AND (INCHES).

### ASSR-4119 6-Pin DIP Package with Gull Wing Surface Mount Option 300

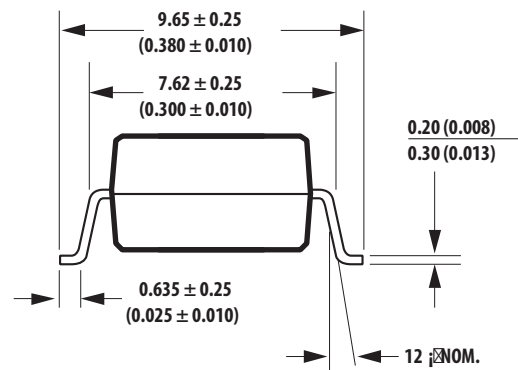
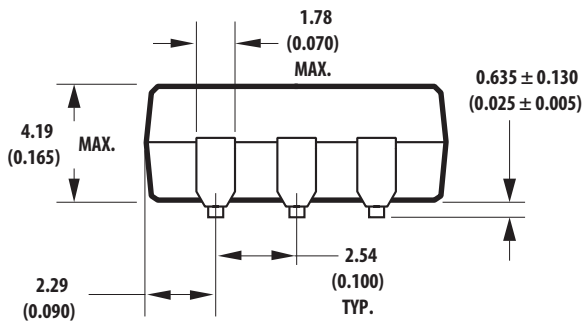
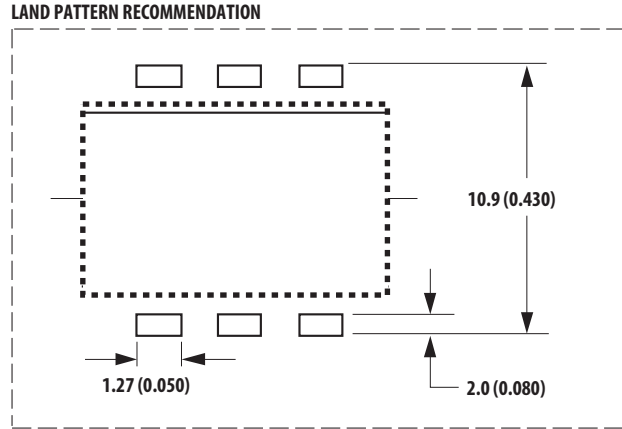
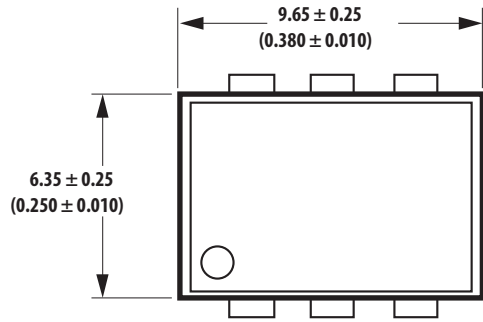

NOTE: FLOATING LEAD PROTRUSION IS 0.25 mm (10 mils) MAX.

### ASSR-4128 8-Pin DIP Package

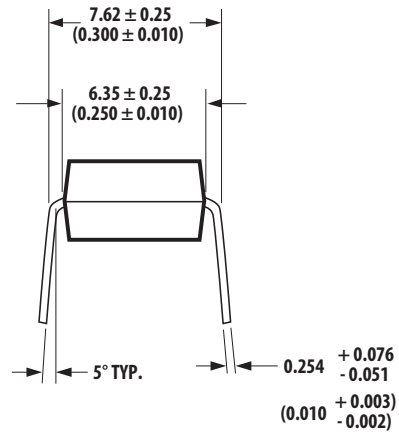
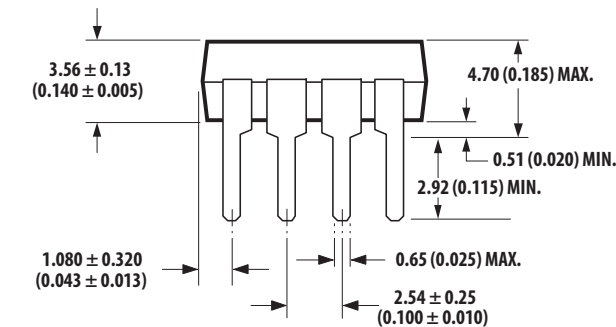
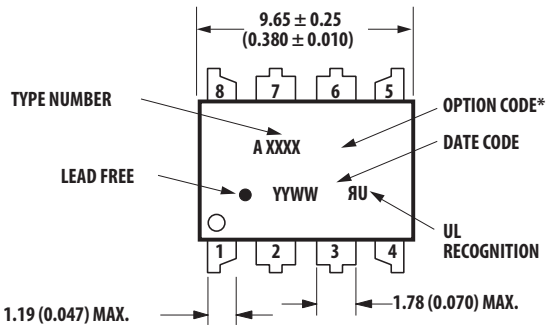

DIMENSIONS IN MILLIMETERS AND (INCHES).  
OPTION NUMBERS 300 AND 500 NOT MARKED.

# ASSR-4128 8-Pin DIP Package with Gull Wing Surface Mount Option 300

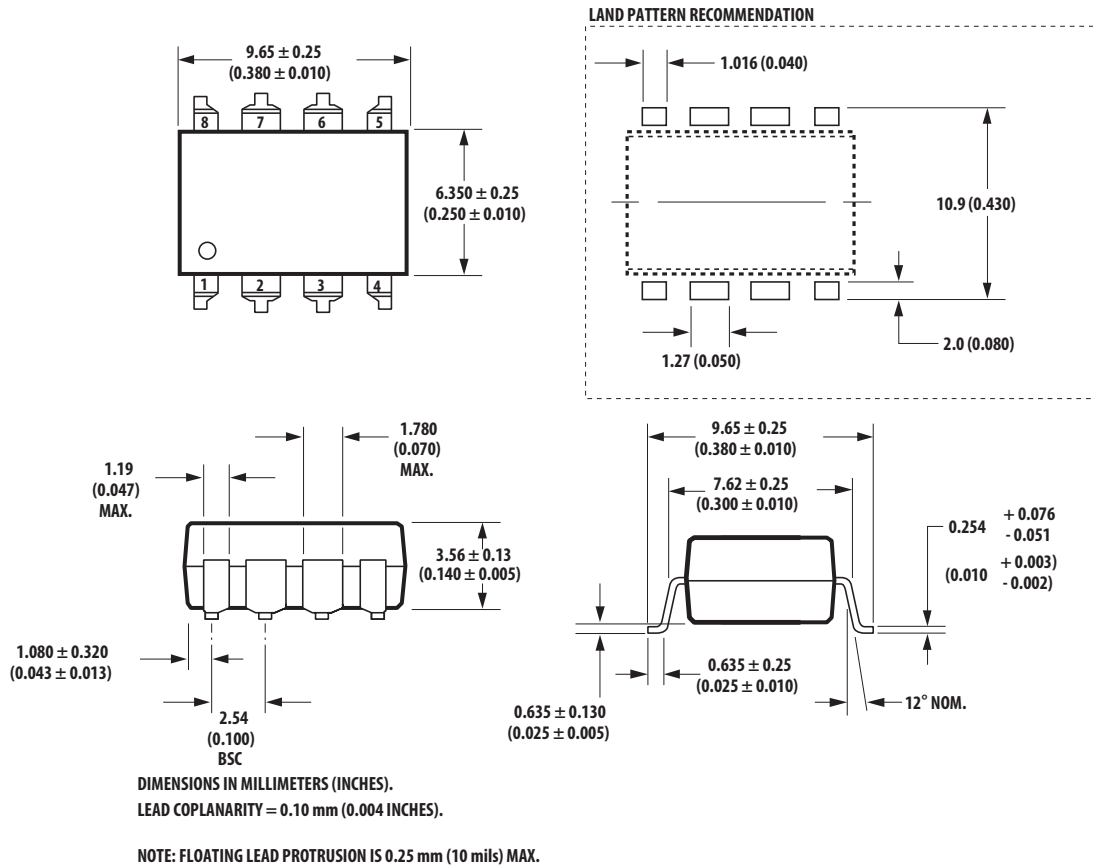

## Lead Free IR Profile

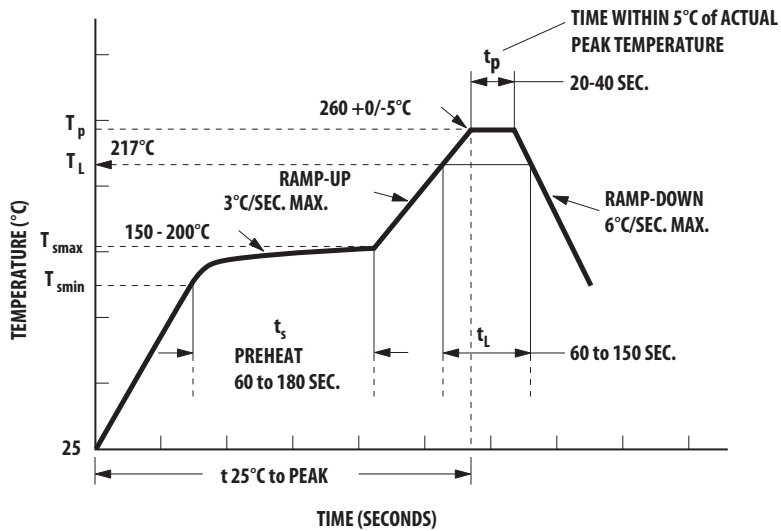

**NOTES:**  
**THE TIME FROM 25°C TO PEAK TEMPERATURE = 8 MINUTES MAX.**  
 **$T_{smax} = 200^\circ\text{C}$ ,  $T_{smin} = 150^\circ\text{C}$**

**Non-halide flux should be used**

## Regulatory Information

The ASSR-4118, ASSR-4119 and ASSR-4128 are pending approval by the following organizations:

### UL

Pending approval under UL 1577, component recognition program up to  $V_{ISO} = 3750 V_{RMS}$

### CSA

Pending approval under CSA Component Acceptance Notice #5.

## Insulation and Safety Related Specifications

Parameter	Symbol	ASSR-4119		Units	Conditions
		ASSR-4118	ASSR-4128		
Minimum External Air Gap (Clearance)	L(101)	4.9	7.1	mm	Measured from input terminals to output terminals, shortest distance through air.
Minimum External Tracking (Creepage)	L(102)	4.9	7.4	mm	Measured from input terminals to output terminals, shortest distance path along body.
Minimum Internal Plastic Gap (Internal Clearance)		0.08	0.08	mm	Through insulation distance conductor to conductor, usually the straight line distance thickness between the emitter and detector.
Tracking Resistance (Comparative Tracking Index)	CTI	175	175	V	DIN IEC 112/VDE 0303 Part 1
Isolation Group (DIN VDE0109)		IIIa	IIIa		Material Group (DIN VDE 0109)

## Absolute Maximum Ratings

Parameter	Symbol	Min.	Max.	Units	Note	
Storage Temperature	$T_S$	-55	125	°C		
Operating Temperature	$T_A$	-40	85	°C		
Junction Temperature	$T_J$		125	°C		
Lead Soldering Cycle	Temperature		260	°C		
	Time		10	s		
Input Current	Average	$I_F$	25	mA		
	Surge		50			
	Transient		1000			
Reversed Input Voltage	$V_R$		5	V		
Input Power Dissipation	ASSR-4118	$P_{IN}$	40	mW		
	ASSR-4119	$P_{IN}$	40	mW		
	ASSR-4128	$P_{IN}$	80	mW		
Output Power Dissipation	ASSR-4118	$P_O$	300	mW		
	ASSR-4119	$P_O$	300	mW		
	ASSR-4128	$P_O$	600	mW		
Average Output Current ( $T_A = 25^\circ\text{C}$ , $T_C \leq 100^\circ\text{C}$ )		$I_O$	0.10	A	1	
	ASSR-4119 Connection B	$I_O$	0.20	A	1	
Output Voltage ( $T_A = 25^\circ\text{C}$ )		$V_O$	-400	400	V	2
	ASSR-4119 Connection B	$V_O$	0	400	V	
Solder Reflow Temperature Profile	See Lead Free IR Profile					

## Recommended Operating Conditions

Parameter	Symbol	Min.	Max.	Units	Note
Input Current (ON)	$I_{F(ON)}$	3	20	mA	3
Input Voltage (OFF)	$V_{F(OFF)}$	0	0.8	V	
Operating Temperature	$T_A$	-40	+85	°C	

## Package Characteristics

Unless otherwise specified,  $T_A = 25^\circ\text{C}$ .

Parameter	Sym.	Min.	Typ.	Max.	Units	Conditions	Note
Input-Output Momentary Withstand Voltage	$V_{ISO}$	3750			$V_{rms}$	$RH \leq 50\%$ , $t = 1 \text{ min}$	4, 5
Input-Output Resistance	$R_{I-O}$		$10^{12}$		$\Omega$	$V_{I-O} = 500 \text{ Vdc}$	
Input-Output Capacitance	ASSR-4118 $C_{I-O}$		0.4		pF	$f = 1 \text{ MHz}$ ; $V_{I-O} = 0 \text{ Vdc}$	4
	ASSR-4119 $C_{I-O}$		0.5		pF	$f = 1 \text{ MHz}$ ; $V_{I-O} = 0 \text{ Vdc}$	
	ASSR-4128 $C_{I-O}$		0.8		pF	$f = 1 \text{ MHz}$ ; $V_{I-O} = 0 \text{ Vdc}$	



## Electrical Specifications (DC)

For operating  $T_A = +25^\circ\text{C}$

Parameter	Sym.	Min.	Typ.	Max.	Units	Conditions	Fig.	Note
Output Withstand Voltage	$ V_{O(OFF)} $	400	450		V	$V_F = 0.8\text{V}, I_O = 250\ \mu\text{A}$	5	
Output Leakage Current	$I_{O(OFF)}$		0.005	1	$\mu\text{A}$	$V_F = 0.8\text{V}, V_O = 400\text{V}$		
Input Reverse Breakdown Voltage	$V_R$	5			V	$I_R = 10\ \mu\text{A}$		
Input Forward Voltage	$V_F$	1.1	1.3	1.6	V	$I_F = 5\text{mA}$	6, 7	
Output On-resistance	$R_{(ON)}$		25	35	$\Omega$	$I_F = 5\text{mA}, I_O = 100\text{mA},$ Pulse $\leq 30\text{ms}$	8, 9	6
	ASSR-4119 Connection B		8	10	$\Omega$	$I_F = 5\text{mA}, I_O = 200\text{mA},$ Pulse $\leq 30\text{ms}$		

## Switching Specifications (AC)

For operating  $T_A = +25^\circ\text{C}$

Parameter	Sym.	Min.	Typ.	Max.	Units	Conditions	Fig.	Note
Turn On Time	$T_{ON}$		0.7	5.0	ms	$I_F = 5\text{mA}, I_O = 100\text{mA}$		
Turn Off Time	$T_{OFF}$		0.04	5.0	ms	$I_F = 5\text{mA}, I_O = 100\text{mA}$		

Notes:

- For derating, refer to Figure 1, 2, 3 and 4.
- The voltage across the output terminals of the relay should not exceed this rated withstand voltage. Over-voltage protection circuits should be added in some applications to protect against over-voltage transients.
- Threshold to switch device is  $I_F \geq 0.5\text{mA}$ , however, for qualified device performance over temperature range, it is recommended to operate at  $I_F = 5\text{mA}$ .
- Device is considered as a two terminal device:  
 ASSR-4118 - pin 1, 2 shorted and pin 3, 4 shorted.  
 ASSR-4119 - pin 1, 2, 3 shorted and pin 4, 5, 6 shorted.  
 ASSR-4128 - pin 1, 2, 3, 4 shorted and pin 5, 6, 7, 8 shorted.
- The Input-Output Momentary Withstand Voltage is a dielectric voltage rating that should not be interpreted as an input-output continuous voltage rating. For the continuous voltage rating refer to the IEC/EN/DIN EN 60747-5-2 Insulation Characteristics Table (if applicable), your equipment level safety specification, or Avago Technologies Application Note 1074, "Optocoupler Input-Output Endurance Voltage."
- During the pulsed  $R_{(ON)}$  measurement ( $I_O$  duration  $\leq 30\text{ms}$ ), ambient ( $T_A$ ) and case temperature ( $T_C$ ) are equal.

## Application Information

### On-Resistance and Derating Curves

The Output On-Resistance,  $R_{(ON)}$ , specified in this data sheet, is the resistance measured across the output contact when a pulse current signal ( $I_o=100\text{mA}$ ) is applied to the output pins. The use of a pulsed signal ( $\leq 30\text{ms}$ ) implies that each junction temperature is equal to the ambient and case temperatures. The steady-state resistance,  $R_{ss}$ , on the other hand, is the value of resistance measured across the output contact when a DC current signal is applied to the output pins for a duration sufficient to reach thermal equilibrium.  $R_{ss}$  includes the effects of the temperature rise in the device.

Figure 1, 2, 3 and 4 specify the maximum average output current allowable for a given ambient temperature. The maximum allowable output current and power dissipation are related by the expression  $R_{ss} = P_o(\text{max}) / (I_o(\text{max}))^2$  from which  $R_{ss}$  can be calculated. Staying within the safe area assures that the steady state MOS-FET junction temperature remains less than  $125^\circ\text{C}$ .

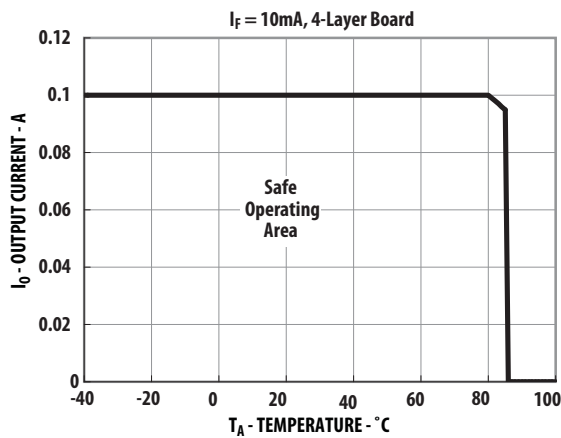

Figure 1. Maximum Output Current Rating vs Ambient Temperature (ASSR-4118-003E)

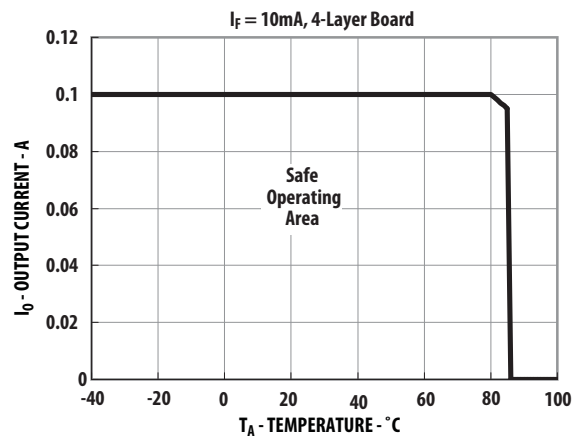

Figure 2. Maximum Output Current Rating vs Ambient Temperature (ASSR-4119-001E)

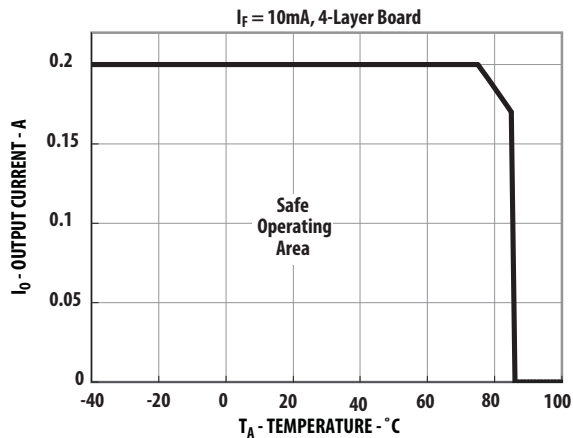

Figure 3. Maximum Output Current Rating vs Ambient Temperature (ASSR-4119-001E DC Connection)

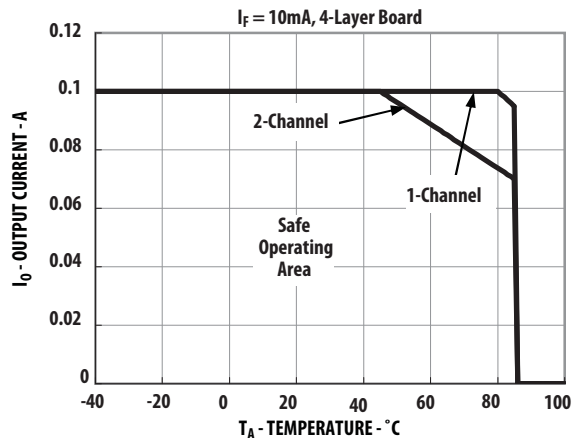

Figure 4. Maximum Output Current Rating vs Ambient Temperature (ASSR-4128-002E)

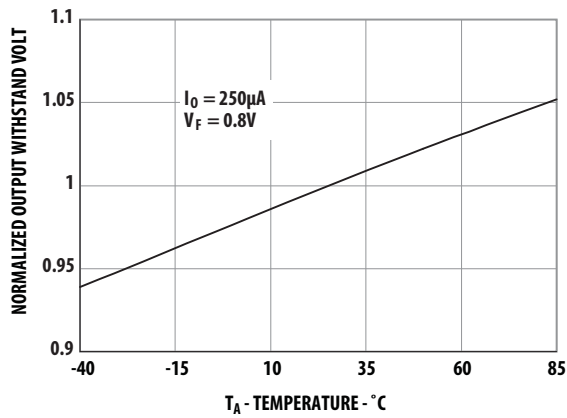

Figure 5. Normalized Output Withstand Voltage vs Temperature

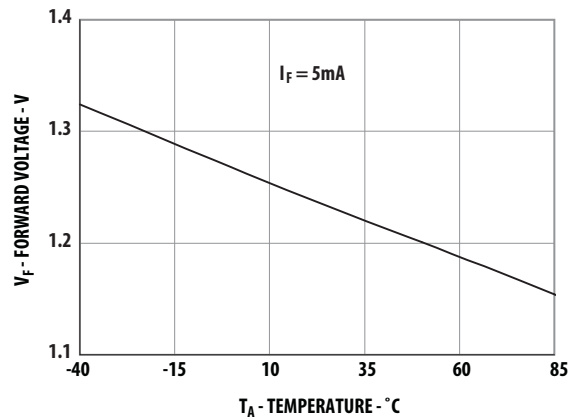

Figure 6. Typical Forward Voltage vs Temperature

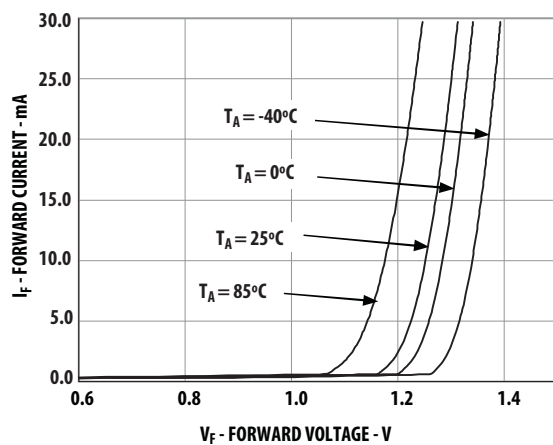

Figure 7. Typical Forward Current vs Forward Voltage

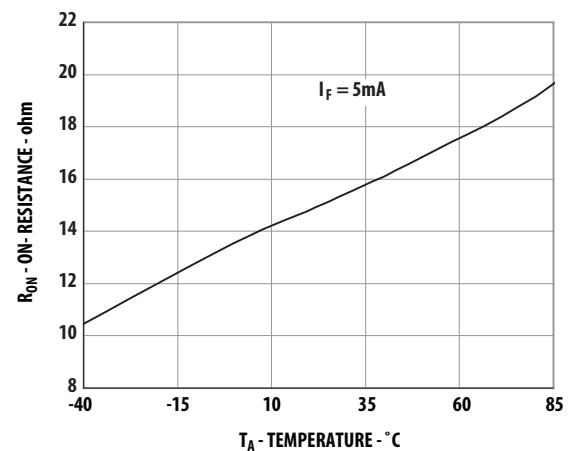

Figure 8. Typical on Resistance vs Temperature

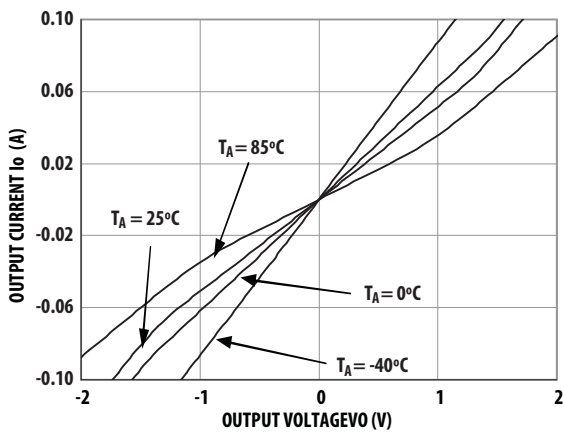

Figure 9. Typical Output Current vs Output Voltage

For product information and a complete list of distributors, please go to our web site: [www.avagotech.com](http://www.avagotech.com)

Avago, Avago Technologies, and the A logo are trademarks of Avago Technologies in the United States and other countries. Data subject to change. Copyright © 2005-2011 Avago Technologies. All rights reserved. AV02-0218EN - February 16, 2011

**AVAGO**  
TECHNOLOGIES