

LOC	DIST	REVISIONS					
HJ	-	P	LTR	DESCRIPTION	DATE	DWN	APVD

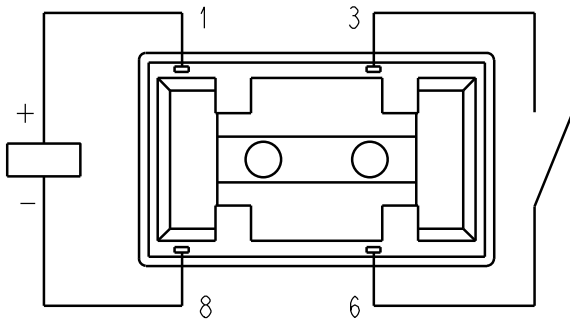

Relay - bottom view

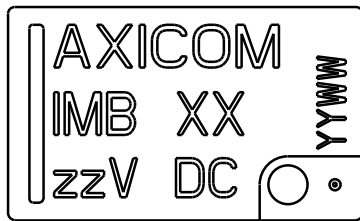
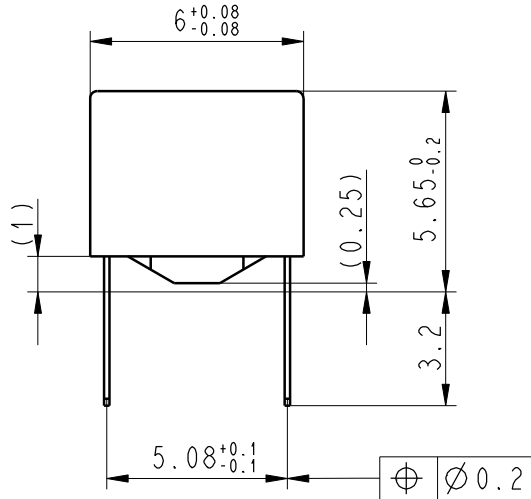
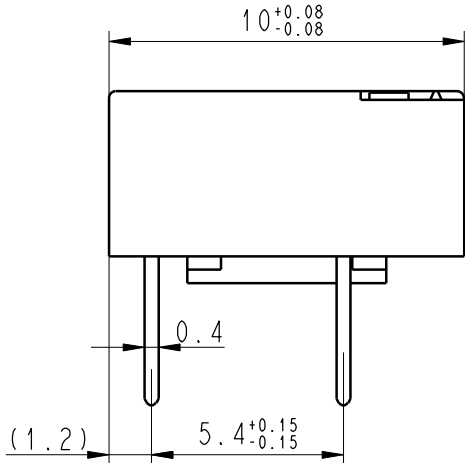

XX = Relay type
zz = nominal voltage
YYWW = Date code

THIS DRAWING IS UNPUBLISHED. © COPYRIGHT 2008 BY TYCO ELECTRONICS CORPORATION. ALL RIGHTS RESERVED.

DIMENSIONS: mm	DWN UKo 9193 18Jun2008	MATERIAL	DRAWING ALIAS	
	CHK HD 9121 18Jun2008	-	FINISH -	
TOLERANCES UNLESS OTHERWISE SPECIFIED: DIN 7168-m	APVD HD 9121 18Jun2008	Tyco Electronics Tyco Electronics Logistics AG Werk Axicom Au, CH-8804 Au ZH		
0 PLC ±-	PRODUCT SPEC -			
1 PLC ±-	APPLICATION SPEC -	SIZE	A4	RESTRICTED TO
2 PLC ±-	WEIGHT -	CAGE CODE	00779	
3 PLC ±-		DRAWING NO	C-1462041-1	
4 PLC ±-				
ANGLES ±-				
	CUSTOMER DRAWING	SCALE	5:1	SHEET 1 OF 1 REV A1