

### Features and Benefits

Universal programming utility  
 Fast development  
 Fast plug-in for software applications  
 Atmega128 Core  
 Firmware updatable via RS232 and USB  
 FPGA updatable via RS232 and USB  
 3 High Current Programmable Supplies  
 1 High Speed Fast  
 16 bit Level Settings  
 16 bit differential Measurements  
 4 analog comparators  
 Vector Generator  
 I2c to Daughter Board  
 Mountable in 19" Rack

### Applications

Experimental tool for Lab and Prototyping  
 Production Equipment for Serial Programming  
 Characterization tool by using mini-tester mode

### Ordering Information

<b>Part No.</b>	<b>Description</b>
PTC04	Programmer Unit (Full Set: including adapter, cables, software, default DB)
PTC04-DB-Hall (included in PTC04)	Default Daughter Board
PTC04-DB-xxxxx	Other Daughter Boards for future products
PTC04-19-x (with x equal to 1 till 4)	19"Rack with build in x number of PTC04

### Accessories

<b>Part No.</b>	<b>Description</b>
PTC04-TestBench-Magnetic	Magnetic utility for evaluating samples on PTC04
PTC-TestBench-4SIP-0x	PCB with 4SIP socket
PTC-TestBench-tssop-so8-0x	PCB with SO Socket and TSSOP Socket
Magnet-T01	Magnet for testing Vertical packaged devices (4SIP-VA, VB and VC)
Magnet-T02	Magnet for testing Horizontal packaged devices with a perpendicular field (SO,TSSOP...)
Magnet-T03	Magnet for testing Horizontal packaged devices with a rotating field (SO, TSSOP...)
Magnet-T04	Magnetic coil for testing Horizontal packaged devices with a perpendicular field (SO, TSSOP...)
Software Environment MPT (Windows)	Including Calibration Software and update tools
DLL for Mini-Tester (Windows)	
DLL's for all supported products (Windows)	
User Inter Faces for most support products (Windows)	

## 1. Functional Diagram

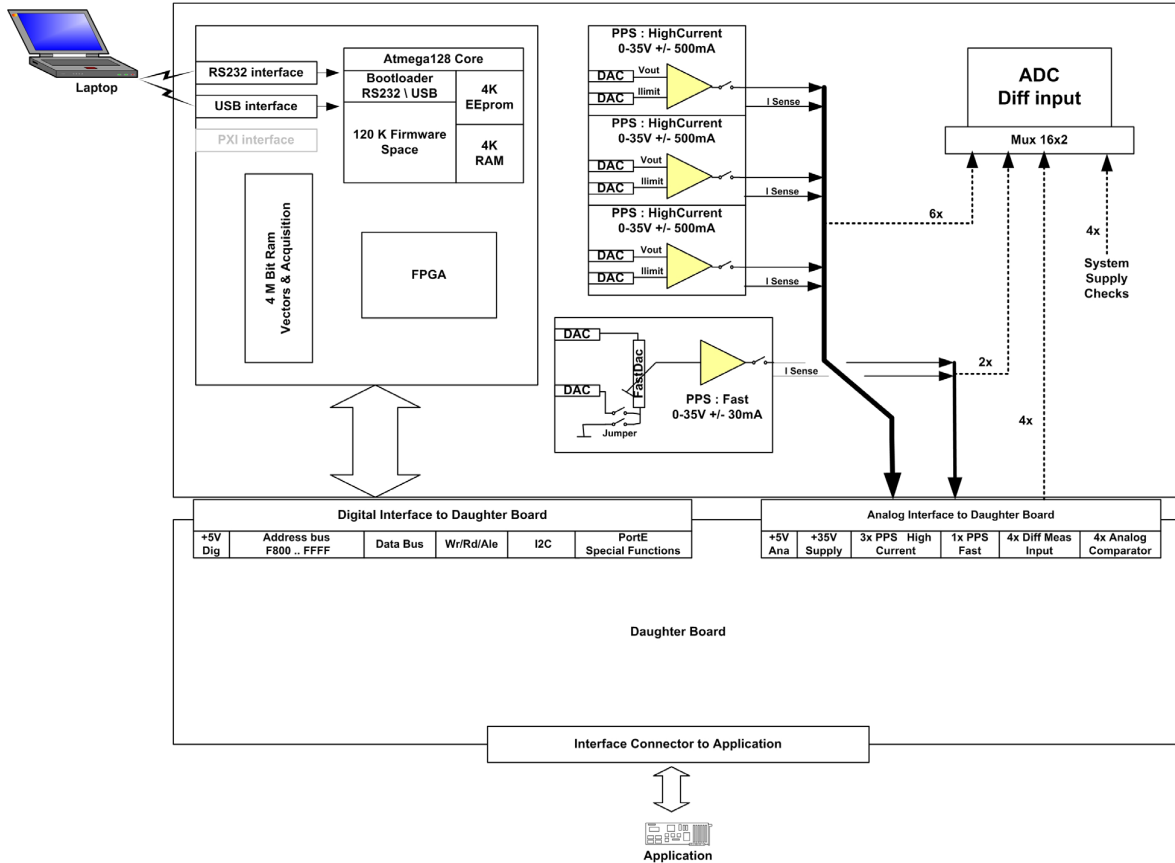

## 2. Description

The PTC-04 programmer was designed for efficient, precise calibration of the Melexis families of programmable ICs. The programmer is designed to be easily adapted to a standard PC and to an application module to allow calibration of programmable sensor ICs within the operating environment. The PTC-04 programmer contains its own programmable power supply and measurement circuitry. The programmer is similar to a standard EEPROM programmer, but adds many special features such as 16 bit voltage and current measurement capability, and configuration options that will accommodate users from the prototyping phase directly into production. An IBM compatible PC is required (not included) to load software to the programmer and control the functions of the programmer.

Communication is done through a standard RS-232 null modem cable to a COM port of the PC or via USB. The PC requires no custom configuration, allowing the programmer to be used with any PC with a COM port speed of 115.2kbs or a standard USB 1.1 or USB 2.0 interface.

## TABLE OF CONTENTS

<b>FEATURES AND BENEFITS .....</b>	<b>1</b>
<b>APPLICATIONS.....</b>	<b>1</b>
<b>ORDERING INFORMATION.....</b>	<b>1</b>
<b>ACCESSORIES .....</b>	<b>1</b>
<b>1. FUNCTIONAL DIAGRAM.....</b>	<b>2</b>
<b>2. DESCRIPTION.....</b>	<b>2</b>
<b>3. GLOSSARY OF TERMS .....</b>	<b>4</b>
<b>4. ABSOLUTE MAXIMUM RATINGS .....</b>	<b>4</b>
<b>5. PTC04 ELECTRICAL SPECIFICATIONS.....</b>	<b>4</b>
5.1. SYSTEM POWER SUPPLY .....	4
5.2. PROGRAMMABLE HIGH CURRENT POWER SUPPLY 1-3 .....	5
5.3. PROGRAMMABLE FAST POWER SUPPLY 4 .....	6
5.4. MEASUREMENT SYSTEM .....	7
5.5. FUNCTION TIMINGS.....	7
<b>6. UNIQUE FEATURES.....</b>	<b>8</b>
6.1. MINI TESTER.....	8
6.2. ANALOGUE VECTOR GENERATOR.....	8
6.3. ACQUISITION MEMORY.....	8
6.4. PORT E ATMEGA128.....	8
<b>7. MAIN BOARD DESCRIPTION .....</b>	<b>9</b>
7.1. BOARD LAYOUT.....	9
7.2. POWER SUPPLIES.....	9
7.3. POWER SUPPLY SYSTEM CHECK .....	10
7.4. SUPPLY CONNECTOR.....	10
7.5. LED INDICATORS.....	10
7.6. USB CONNECTOR .....	10
7.7. RS 232 CONNECTOR .....	10
7.8. RESET BUTTON.....	10
7.9. DAUGHTER BOARD CONNECTORS .....	11
<b>8. DAUGHTER BOARD CONCEPT .....</b>	<b>13</b>
8.1. BACKGROUND.....	13
8.2. REQUIREMENTS.....	13
<b>9. RS 232 COMMUNICATION WITH HOST .....</b>	<b>14</b>
9.1. CONNECTOR.....	14
9.2. CABLE.....	14
9.3. SETTINGS .....	14
<b>10. USB COMMUNICATION WITH HOST.....</b>	<b>15</b>
10.1. CONNECTORS .....	15
10.2. CABLE.....	15
10.3. SETTINGS .....	15
<b>11. MEASUREMENT SYSTEM .....</b>	<b>16</b>
11.1. CHANNELS .....	16
11.2. CONVERSION TIME .....	16
11.3. ACCURACY .....	16
<b>12. ESD PRECAUTIONS.....</b>	<b>16</b>
<b>13. MECHANICAL OUTLINES.....</b>	<b>17</b>
<b>14. DISCLAIMER.....</b>	<b>18</b>

### 3. Glossary of Terms

PTC04: The programmer (including the applicable DB)  
 DB: Daughter board

### 4. Absolute Maximum Ratings

Supply Voltage (External input)	48V
Reverse Voltage Protection	Yes
Supply Current	1 A Fused
PPS 1,2,3 Output	34 V
PPS 1,2,3 Current (peak value)	500mA
PPS 4 : Output Current, I <sub>OUT</sub> (peak value)	50 mA
Operating Temperature Range, T <sub>A</sub>	25 °C
Operating Temperature Range, T <sub>S</sub>	0°C – 55 °C

Exceeding the absolute maximum ratings may cause permanent damage. Exposure to absolute-maximum-rated conditions for extended periods may affect device reliability.

### 5. PTC04 Electrical Specifications

#### 5.1. System Power Supply

DC Operating Parameters T<sub>A</sub> = 25-35°C, V<sub>ext</sub> = 48V (unless otherwise specified)

Parameter	Symbol	Test Conditions	Min	Typ	Max	Unit
DC System Power Supply	V <sub>ext_in</sub>		23	48	48.2	V
System Current Consumption	I <sub>Ext_in</sub>		0.1		1.2	A
Daughter Board Analog Power Supply *					36	V
				500		mA
Daughter Board Digital Power Supply				5		V
				500		mA

\* Depends on the DC System Power Supply

### 5.2. Programmable High Current Power Supply 1-3

DC Operating Parameters  $T_A = 25-35^\circ\text{C}$ ,  $V_{\text{ext}} = 48\text{V}$  (unless otherwise specified)

Parameter	Symbol	Test Conditions	Min	Typ	Max	Unit
Output voltage range *	VPPS 1-3	Unloaded	0.62		34.00	V
Output resolution				0.52		mV
Output Current (peak value)	I PPS 1-3		-500		500	mA
Current Limit range	I limPPS 1-3		-500		500	mA
Settling time		Unloaded	10		20	$\mu\text{s}$
Voltage Source Swing PPS1-PPS3	Vout	I out = 10mA	0.035		34	V
		I out = 100mA	0.2		32.5	V
		I out = 500mA	1.15		26	V
		I out = -10mA	1.14		34	V
		I out = -100mA	2.3		30	V
		I out = -500mA	9.46		30	V
Voltage Source Accuracy		PPS1-3, I out = 10mA	-1		+1	%
			-1.05		+1.05	mV
Voltage Source Slew Rate		PPS1-3, C load = 100nF	2.5			V/ $\mu\text{s}$
		PPS1-3, C load = 1 $\mu\text{F}$	0.5			
		Between 20 & 80%				

\* Depends on the DC System Power Supply

### 5.3. Programmable Fast Power Supply 4

DC Operating Parameters  $T_A = 25-35^\circ\text{C}$ ,  $V_{\text{ext}} = 48\text{V}$  (unless otherwise specified)

Parameter	Symbol	Remarks	Min	Typ	Max	Unit
Output voltage range	VPPS 4	When Fast DAC = 255	0.37		13	V
Output resolution				0.2		mV
Output Current (peak value)	IPPS 4		-50		50	mA
Fast DAC resolution		Divider between Pos and Neg voltage		8		bits
Settling time		This is taken by changing the Fast DAC only	0.5		5	$\mu\text{s}$
Voltage Source Swing PPS4	Vout	I out = 10mA I out = 50mA	1 0.5		13 10	V
Voltage Source Accuracy		PPS4, I out = 10mA	-1 -0.8		+1 +0.8	% mV
Voltage Source Slew Rate Using 8 bit Fast DAC		PPS4, C load = 100nF PPS4, C load = 1 $\mu\text{F}$ Between 20 & 80%	0.25 0.08			V/ $\mu\text{s}$

### 5.4. Measurement system

DC Operating Parameters  $T_A = 25-35^{\circ}\text{C}$ ,  $V_{\text{ext}} = 48\text{V}$  (unless otherwise specified)

Parameter	Symbol	Test Conditions	Min	Typ	Max	Unit
ADC Channels				16		
Pin Potential			-0.5		35.5	V
Voltage range (full mode)			-37.5		37.5	V
Resolution (full Mode)				1.15		mV
Accuracy (full Mode)			-0.1 -1.15		+0.1 +1.15	% mV
Voltage range (fine mode)			-7.8		7.8	V
Resolution (fine Mode)				0.24		mV
Current Meter Range		PPS1-3 PPS4	-500 -50		500 50	mA
Resolution (full Mode)		PPS1-3 PPS4		77 52		$\mu\text{A}$
Current Meter Accuracy		PPS1-3 PPS4	-2 -0.312 -2 -0.5		+2 0.312 +2 0.5	% mA % mA

### 5.5. Function Timings

DC Operating Parameters  $T_A = 25-35^{\circ}\text{C}$ ,  $V_{\text{ext}} = 48\text{V}$  (unless otherwise specified)

Parameter	Symbol	Remarks	Min	Typ	Max	Unit
Voltage Source Program Rate		PPS1-4, Using PC Software and RS232 interface		20		mS
		Using vector functions	10			$\mu\text{S}$
Voltage Source Noise		PPS1-4, Peak-to-peak		2	5	mV
Current Measurement Sample Time		Firmware Only		0.5		mS
		PC software and RS232		20		

## **6. Unique Features**

### **6.1. Mini Tester**

Due to the architecture of the Hardware in combination with the Software, the PTC04 can be used as a mixed mode tester. (With limited performance)

There are library routines (DLL) available in order to interface with any software language. (C, C++, Visual Basic, Lab view, Excel(VBA)...)

### **6.2. Analogue Vector Generator**

A vector space of 512Kbyte allows you to store a huge amount of actions. These actions consist of setting a level on a channel, waiting a time x, setting the Fast DAC and making samples on an analogue input (measurement) or a digital comparator. For details, refer to the PSF of the PTC04 chapter Pattern functions.

### **6.3. Acquisition memory**

An advance library on the Analogue vector generators, allows use of the vector area in combination with Measurement and setting levels. Through this method one may use the PTC04 as a slow Data acquisition card.

### **6.4. Port E Atmega128**

The port E of the Atmega128 core is connected fully to the Daughter board.

With this port, items like critical timing generation measurements can be performed. Also, all types of UARTS can be configured. Other capabilities are possible with the PTC04.

For more details, refer to the Atmega128 datasheet



## 7. Main Board description

### 7.1. Board Layout

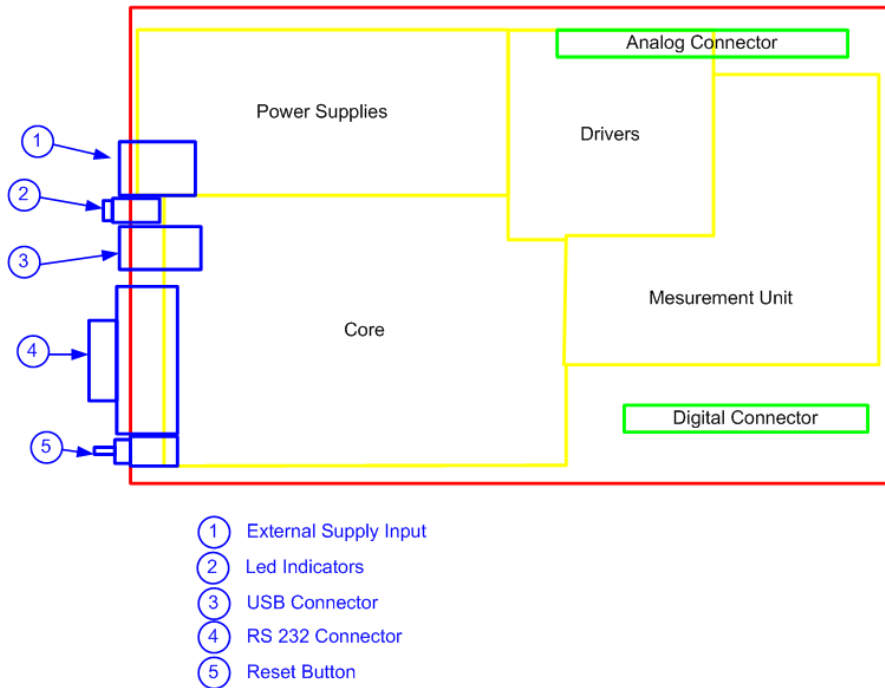

Figure 7-1

As shown in Figure 7-1, The Main board can be divided in 4 major areas.

- The Supplies where all required voltage and current levels are created
- The digital Core that processes all requests from the host computer
- A Driver Area where the Programmable Power supplies are located
- A Measurement area where the ADC and the input MUX are located

Beside these four areas, there are the input connector on the main board and the two connectors to the daughter board.

### 7.2. Power Supplies

The Power Supply input connector is a single input to supply the whole PTC. The Input supply requires a minimum of 24 volts and can tolerate a maximum of 48 volts. It is not recommended to use a higher voltage than needed for the application. There's an internal fuse (on the main board) of 1 A in order to avoid damage when improperly used. The connected supply should provide a minimum current of 1.5 A with peak capacity to source 10A.

The external Supply is the source to create all the internal requirements. Internal voltages are created on the main board by using the input voltage from the external supply.

- +35V for drivers (for the drivers or Programmable Power Supplies)
- +5V Digital (Digital core as interface between PTC and Host application)
- +5V Analog (measurement circuit with MUX and ADC)
- +3.3 V Digital (Supply for the FPGA and USB)

### **7.3. Power Supply system check**

When something goes wrong it's useful to check the status of all the above mentioned supplies. The main board has the capability to measure all internal supplies. The only requirement is that the +5V Digital supply is available. This is indicated by the red led on the rear panel of the programmer. All the other supply could be checked by the Measurement system itself. Channels 8 till 11 are reserved for this. The channel 8 is connected to the driver supply and is very useful to check the voltages of the connected external supply. This can be useful to check when applications are launched where extra high voltage is needed. Refer to the chapter "Measurement system" for more details about measuring these channels. There are DLL functions available that will do these checks for you.

A typical diagnostic check will start with checking if the external supply is available. Then it will check if the red led is lit. If these steps are ok, the diagnostics via software can be executed.

### **7.4. Supply Connector**

This connector provides the PTC with power. Any power source that generates a voltage between 24 and 48 V DC with a minimum current of 1.5 A is allowed.



Figure 7-2

### **7.5. LED Indicators**



Two Led indicators will help the user to check the status of the PTC  
The red led shows that the core inside has power  
The green led will show a busy status. If the Programmer is executing a job, the led will be on.

Figure 7-3

### **7.6. USB Connector**

One of the communication possibilities with the host PC is the USB link. See chapter "USB communication with host" for more details

### **7.7. RS 232 Connector**

One of the communication possibilities with the host PC is the serial Communication. See chapter "RS communication with host" for more details

### **7.8. Reset button**

This button is connected to all reset lines in the main board as well as on the daughterboard. This button allows the user to reset the whole programmer after crashing software and when connected also to the application device under test.

### 7.9. Daughter board Connectors

The main board has two connectors to the interface with the application. The PTC allows the addition of a full PCB in between the main board and the interface. This daughter board can be mounted on the two connectors. In some exceptional cases, a daughter board contains only a few wires from the Analog connector to the application connector.

The connectors are described below.

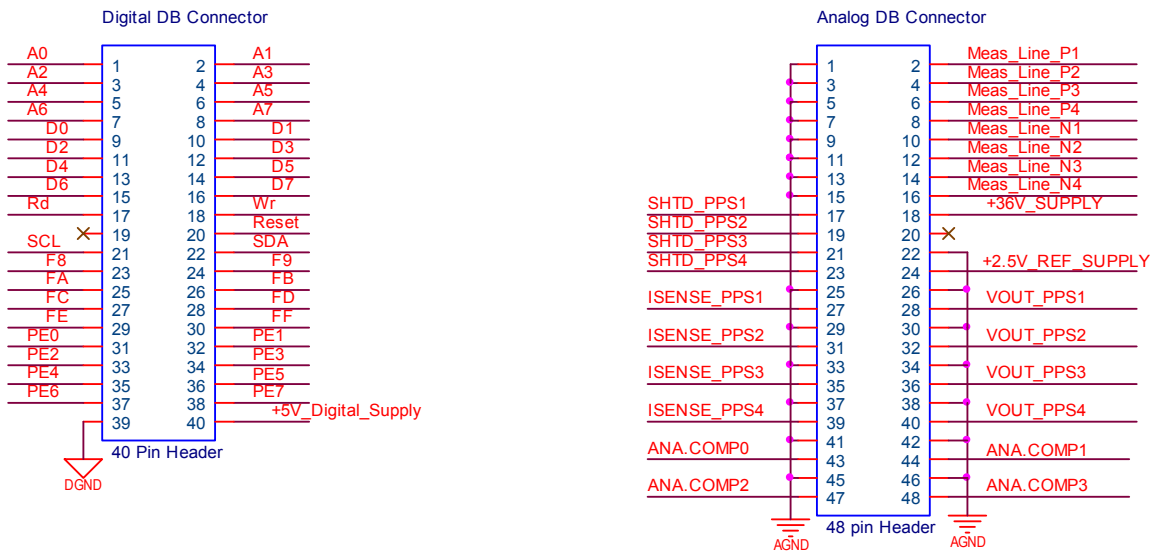

### 7.9.1. Digital DB Connector (40 Pins)

Mainly, the digital connector is meant to expand the programmer for extra needs. Address lines A0-A7 together with the Map Select Lines F8-FF allows the user direct access to an area of 2 K. Example would be adding a simple addressed I/O register by using the selection lines. If more complexity is needed, a full FPGA can be mounted on the DB board

Pins	Names	Description
1 – 8	A0 – A7	Address lines
9 – 16	D0 – D7	Data Lines active during Rd or Wr signals
17	Rd	Read : A negative pulse will indicate a sampling of the data on the Data Bus
18	Wr	Write : A Negative pulse will indicate when data is available on the Data Bus
20	Reset	This signal goes low by powering the PTC or by pressing the reset button. This line can be pulled low by application. Check firmware documentation for resetting by software.
21-22	SCL / SDA	I2c Bus
23-30	F8,F9,...,FF	CS lines when the address areas are accessed
31-38	Port E	Note: These pins are limited to 5 Volt input/output!!!! The full Port E of the Atmega core is mounted to these pins. This allows us to use advanced features like PWM, UARTS, Time Measurements, etc.... By using firmware that supports these functions, really nice application specific requirements can be fulfilled.
39	DGND	Digital Ground
40	+5V Digital	5 Volt Digital Supply. Maximum current to get out of this supply : ....mA

Note: All the pins are limited to 5 Volt input/output!!!! However, there are protections, please take precautions in order to avoid damage of the main board.

### 7.9.2. Analog DB Connector (48 Pins)

Mainly, the analog connector provides all the analog signals and measure possibilities.

Pins	Names	Description
28,32,36	PPS 1-3	Output of the Programmable Supplies
40	PPS 4	Output of the Fast DAC Programmable Power Supply
27,31,35,39	Isense_PP1-4	Outputs (Driver outputs before Rsens) for current evaluations. These outputs could be used to connect to the analog comparators in order to create fast digital signals based on current.
2,4,6,8	ExtMeas1-4Pos	There are 4 differential inputs for making measurements
10,12,14,16	ExtMeas1_4Neg	The negative inputs of ExtMeas1-4Pos
17,19,21,23	Shtd_PPS1-4	Outputs that show the status of the Drivers. Signals are meant to connect LED's for the front panel
43,44,47,48	AnaComp0-3	See *Note. Input (limited to 5V) Fast Level comparators in order to remove time consuming measurement
18	+35V_Supply	Supply to extend the daughter board with some extra drivers
20	NC	Not Connected
24	+2.5V Ref	Output of internal reference
All other	AGND	Analog Ground

Note: All the pins are limited to 35 Volt input/output!!!! However, there are protections, please take precautions in order to avoid damage of the main board.

\* Note: Some pins are protected and limited to 5 Volt!!!! However, there are protections, please take precautions in order to avoid damage of the main board.

## 8. Daughter board concept

### 8.1. Background

The future of our products is not known and building a universal programmer will not be possible to survive more than a few years. For this reason, a flexibility is build in by having a Daughter board (abbreviation: DB) as interface between PTC04 and the application connector. On this way, special needs can be fulfilled.

The simplest DB is just wires form the DB connectors to the application connector.

The idea is to support with one single DB as many as possible products.

### 8.2. Requirements

See specific daughter board documentation.

## 9. RS 232 Communication with host

This page describes all items concerning the hardware of the RS232C communication link. Information about the protocol is explained in the software documentation.

### 9.1. Connector

DB9-Male	Description
2	RxD
3	TxD
5	GND

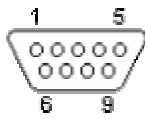

(At the Computer and at the PTC04)

9 PIN D-SUB MALE at the Computer.

### 9.2. Cable

The cable between PTC and Host PC is a standard null-modem cable for RS232C  
Cable Description:

DB9-FEM	DB9-FEM	Description
2	3	RxD / TxD
3	2	TxD / RxD
5	5	GND

### 9.3. Settings

The microprocessor core has a fixed setting to communicate with the host.  
Used settings are as follows

Parameter	Value
Baud rate	115, 2 kBps
Bits	8
Parity	No
Flow Control	None
Sop bits	1

## 10. USB Communication with host

Universal Serial Bus (USB) is used (V1.0)

Developed by Compaq, Hewlett-Packard, Intel, Lucent, Microsoft, NEC and Phillips.

### 10.1. Connectors

Pin	Name	Description
1	VBUS	+5 VDC
2	D-	Data -
3	D+	Data+
4	GND	Ground

### 10.2. Cable

Default:



USB A (at the Connector) to plug into a PC



USB B (at the Connector) to plug into the PTC04

Series "A" plugs are used towards the host system and series "B" plugs are used towards the USB device.

### 10.3. Settings

2 drivers have to be installed and are available on the Software CD

## 11. Measurement system

The measurement system on the main board contains mainly a high accurate 16 bit ADC and two 16 to 1 channels MUX. Basically, the ADC always measures differential between inputs.

For the internal voltage channels, the negative input is the internal analog ground.

For the current measurements that use a sense resistor (PPS1-4) are clearly measuring over the sense resistor.

There are also 4 full differential lines going to the daughter board allowing the user to make high quality measurements by selecting the reference by the application itself. This way of working easily supports the use of force and sense lines.

### 11.1. Channels

Nr	Pos input	Neg input	Description
0	Vout PPS1	Internal AGND	Output Voltage PPS1
1	V driver PPS1	Vout PPS1	Output Current PPS1
2	Vout PPS2	Internal AGND	Output Voltage PPS2
3	V driver PPS2	Vout PPS2	Output Current PPS2
4	Vout PPS3	Internal AGND	Output Voltage PPS3
5	V driver PPS3	Vout PPS3	Output Current PPS3
6	Vout PPS4	Internal AGND	Output Voltage PPS4
7	V driver PPS4	Vout PPS4	Output Current PPS4
8	Supply Driver: +35/2	Internal AGND	Driver Supply divide by 2
9	Supply Analog : +5 V	Internal AGND	Analog 5V Supply
10	Supply Digital : +5 V	Internal AGND	Digital 5V Supply
11	Reference : +2.5V	Internal AGND	Reference Voltage for DAC\ADC
12	DB_Ana_conn Pin 2	DB_Ana_conn Pin 10	Daughterboard Meas. Channel 1
13	DB_Ana_conn Pin 4	DB_Ana_conn Pin 12	Daughterboard Meas. Channel 2
14	DB_Ana_conn Pin 6	DB_Ana_conn Pin 14	Daughterboard Meas. Channel 3
15	DB_Ana_conn Pin 8	DB_Ana_conn Pin 16	Daughterboard Meas. Channel 4

### 11.2. Conversion time

In general the conversion time depends on the loaded firmware version. Theoretically, a full conversion to a floating real value takes about 4ms if the filter is put at 100 samples.

### 11.3. Accuracy

To preserve the accuracy of the PTC04, Melexis recommends checking the tolerance of the PTC04 once a year.

## 12. ESD Precautions

Electronic semiconductor products are sensitive to Electro Static Discharge (ESD).

Always observe Electro Static Discharge control procedures whenever handling semiconductor products.



### 13. Mechanical Outlines

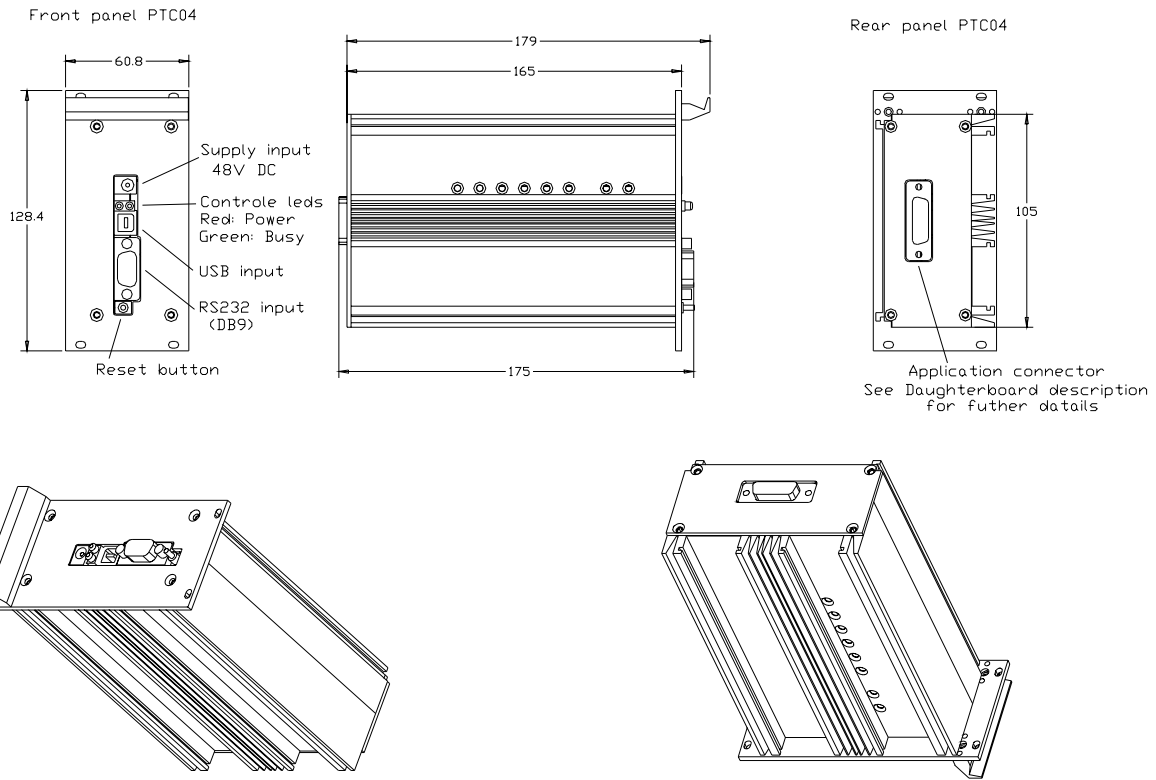

## **14. Disclaimer**

Devices sold by Melexis are covered by the warranty and patent indemnification provisions appearing in its Term of Sale. Melexis makes no warranty, express, statutory, implied, or by description regarding the information set forth herein or regarding the freedom of the described devices from patent infringement. Melexis reserves the right to change specifications and prices at any time and without notice. Therefore, prior to designing this product into a system, it is necessary to check with Melexis for current information. This product is intended for use in normal commercial applications. Applications requiring extended temperature range, unusual environmental requirements, or high reliability applications, such as military, medical life-support or life-sustaining equipment are specifically not recommended without additional processing by Melexis for each application.

The information furnished by Melexis is believed to be correct and accurate. However, Melexis shall not be liable to recipient or any third party for any damages, including but not limited to personal injury, property damage, loss of profits, loss of use, interrupt of business or indirect, special incidental or consequential damages, of any kind, in connection with or arising out of the furnishing, performance or use of the technical data herein. No obligation or liability to recipient or any third party shall arise or flow out of Melexis' rendering of technical or other services.

© 2010 Melexis NV. All rights reserved.

For the latest version of this document, go to our website at  
[www.melexis.com](http://www.melexis.com)

Or for additional information contact Melexis Direct:

Europe, Africa, Asia:  
Phone: +32 13 670 495  
E-mail: [sales\\_europe@melexis.com](mailto:sales_europe@melexis.com)

America:  
Phone: +1 603 223 2362  
E-mail: [sales\\_usa@melexis.com](mailto:sales_usa@melexis.com)

ISO/TS 16949 and ISO14001 Certified