

AVR[®]EMBEDDED
INTERNET
TOOLKIT

The AVR[®] Embedded Internet Toolkit is a complete hardware and software solution and reference platform that gives designers the ability to add Internet access capability to low cost embedded applications. Included in the kit is a megaAVR microcontroller, dedicated hardware and all required software protocols for connection to the Internet, including a full TCP/IP stack. For applications not needing the highest transfer speed, like industrial and home automation applications, the Embedded Internet Toolkit offers a low cost, easy to use solution. No additional licensing is needed once the kit is purchased. The AVR Embedded Internet Toolkit includes the following features:

- Full TCP/IP Support
- HTTP1.1 Enables Direct Web Browser Access
- FTP for Up- and Downloading Files from Anywhere on the Internet
- SMTP Support for Sending Mail
- DHCP for Automatic Network Configuration
- ARP, UDP, ICMP Protocol Support
- File System for Accessing Files in Flash Memory
- Ethernet Interface to Crystal CS8900 Ethernet Controller
- 128K Bytes AVR On-chip Flash Memory for Application Program
- Low Level Ethernet Interface Drivers
- Up to 1 MB External Flash Memory for Web Pages and Data Storage
- Example Applications for Controlling External Equipment
- Web Server Examples
- Modular C-code Allows Easy Update and Changes
- Windows[®] Configuration Software Included
- Quick Start Guide for Immediate Internet Access
- Complete Documentation of API to all Protocols

The ATMEL logo, consisting of the word 'ATMEL' in a bold, stylized, sans-serif font with a registered trademark symbol (®) to the right.

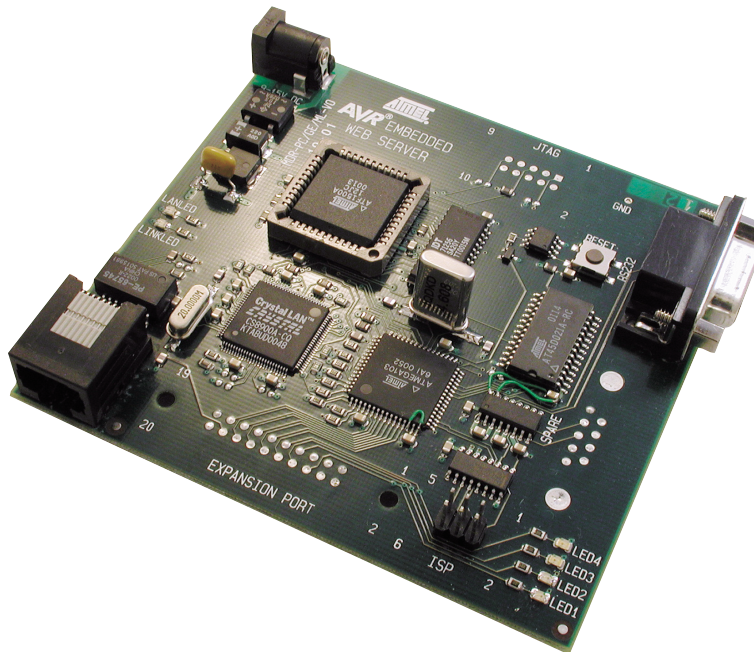

Corporate Headquarters

2325 Orchard Parkway
San Jose, CA 95131
Tel: (408) 441-0311
Fax: (408) 487-2600

Europe

Atmel SarL
Route des Arsenaux 41
Casa Postale 80
CH-1705 Fribourg
Switzerland
Tel: (41) 26-426-5555
Fax: (41) 26-426-5500

Asia

Atmel Asia, Ltd
Room 1219
Chinachem Golden Plaza
77 Mody Road
Tsimshatsui East, Kowloon
Hong Kong
Tel: (852) 2721-9778
Fax: (852) 2722-1369

Japan

Atmel Japan K.K.
9F, Tonetsu Shinkawa Bldg.
1-24-8 Shinkawa
Chuo-ku, Tokyo 104-0033
Japan
Tel: (81) 3-3523-3551
Fax: (81) 3-3523-7581

e-mail

literature@atmel.com

Web Site

<http://www.atmel.com>

©Atmel Corporation 2001

Atmel Corporation makes no warranty for the use of its products, other than those expressly contained in the Company's standard warranty which is detailed in Atmel's Terms and Conditions located on the Company's web site. The Company assumes no responsibility for any errors which may appear in this document, reserves the right to change devices or specifications detailed herein at any time without notice, and does not make any commitment to update the information contained herein. No licenses to patents or other intellectual property of Atmel are granted by the Company in connection with the sale of Atmel products, expressly or by implication. Atmel's products are not authorized for use as critical components in life support devices or systems.

Atmel® and AVR® are registered trademarks of Atmel Corporation.

Windows® are registered trademark of Microsoft Corporation.

Other terms and product names in this document may be trademarks of others.

2493A-01/02/10M

The AVR Embedded Internet Toolkit includes all required hardware and software for developing systems connected to the Internet. It is perfect for inexperienced developers who want to explore the possibilities of Embedded Internet as well as experienced designers who can use the low level network interface for building applications connected to the Internet. Typical applications are:

- Home Appliances
- Industrial Control
- Remote Gas and Power Meter Control
- Vending Machines
- Digital Cameras
- Point of Sale Terminals
- Smart Card Readers
- UPS
- Networking Equipment
- Alarm Systems
- A/C Control
- MP3 Players
- Sensors
- Games and Toys
- Information Displays

The kit includes all the common protocols of the TCP/IP protocol suite. The protocol suite is developed in C programming language and takes advantage of AVR's superior high-level language efficiency. A powerful Application Program Interface (API) allows user applications to be written in high-level languages, providing shorter design times and easier maintenance of the code.

The hardware includes Flash memory for both program memory and web page storage. The AVR microcontroller with In-System Programmable Flash memory allows very fast application upgrades. The flexible design allows web page upgrades from anywhere on the Internet.

Support for HTTP (HyperText Transfer Protocol) makes it possible to access web pages in the Flash memory from a standard web browser on a PC. The kit supports both sending and reception of data from web pages. This enables control and monitoring of external equipment and easy generation of dynamic web pages.

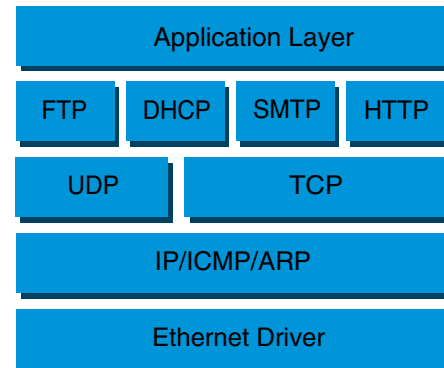

Embedded Internet Toolkit Software

The software is completely modular and can be recompiled for any AVR device. The modularity of the code makes it easy to port the code to any Real Time Operating System, and to replace parts of the code with upgraded versions, or thinner solutions to save codespace.

The modular construction allows designers to select the required protocols, build a complete application, and download it into Flash memory.

The kit includes configuration software for configuring and setting up the Internet connection. The configuration can also be changed from anywhere on the Internet using FTP (File Transfer Protocol). The kit includes a quick start guide as well as complete technical documentation and full schematics.

Ordering Information for the AVR Embedded Internet Toolkit

The AVR Embedded Internet Toolkit is available from Atmel's franchised distributors, the ordering code is AT90EIT1. Technical information, userguide and the latest software can be downloaded from the Atmel web site, www.atmel.com.