

MPC8377E and MPC8379E Reference Design Boards

The MPC8377E-RDB and MPC8379E-RDB provide customers with highly integrated reference design boards that can help shorten customers' time to market. The reference designs are aimed at small-to-medium business and consumer applications, such as network attached storage (NAS) with RAID 5, multi-function printers and office-in-a box. The cost-effective boards are based on the MPC837x family, built on Power Architecture™ technology, along with leading-edge external components to help customers quickly design and implement their target application.

The MPC8377-RDB leverages the MPC8377E processor while the MPC8379E-RDB enables the MPC8379E. The MPC837x family is based on the e300 core, built on Power Architecture technology, which has a frequency range of 400–667 MHz, and supports a 32K instruction and L1 data cache. The MPC837x family also supports two Gigabit Ethernet controllers, USB 2.0, PCI 2.3, 64/32-bit DDR1/2 and an integrated security engine. The MPC8377E supports **two** x1 PCI Express® and two Serial-ATA II (SATA II) controllers, while the MPC8379E supports **four** SATA II controllers. The new MPC837x family, based in 90 nm process technology, provides high integration that simplifies board design and offers a cost-effective solution.

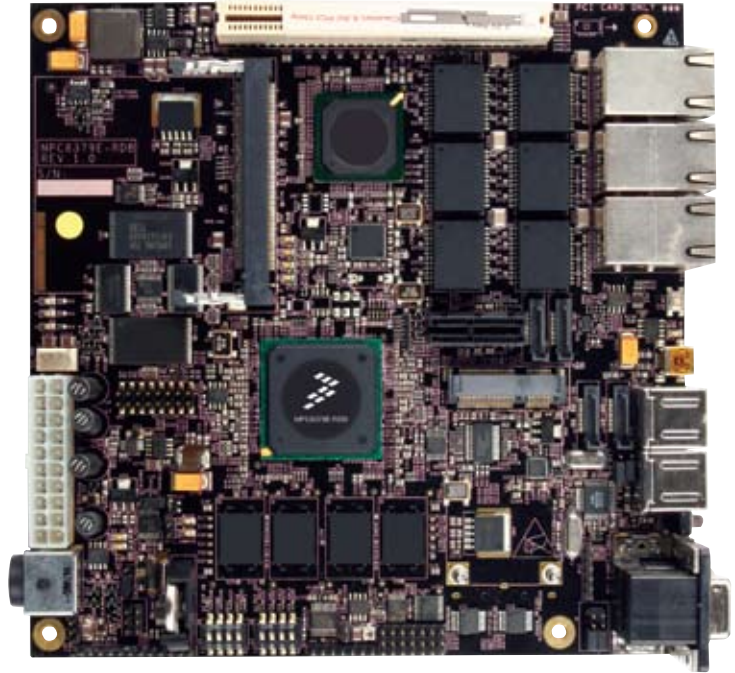

The MPC8377E-RDB and the MPC8379E-RDB platforms feature 256 MB unbuffered DDR2 SDRAM, 8 MB NOR flash and 32 MB NAND flash, where the platforms can boot from either NOR or NAND flash. They include both a Gigabit PHY and a 5-port Ethernet switch, as well as a 4-port USB hub or a 1-port USB on-the-go (OTG). The MPC8377E-RDB also supports a PCI Express add-in connector and a MiniPCI Express slot. The MPC8379E-RDB platform also supports up to four SATA II connectors. These components, integrated with the MPC837x family, provide

an application-specific platform that can help customers to get a jump start on their next application design.

Along with the hardware support, the MPC8379E-RDB and MPC8377-RDB come with a board support package (BSP) that includes both U-boot and Linux® 2.6 support. The platform is also available with third-party software applications. To see demonstrations or to acquire details of Freescale's third-party applications for this platform, please contact your local Freescale sales office.

MPC8379-RDB and MPC8377-RDB Boards Features

- CPU: Freescale MPC8379E or MPC8377E
- Memory subsystem
 - 256 MB unbuffered DDR2 SDRAM
 - 8 MB NOR flash
 - 32 MB NAND flash
 - 256 Kb serial EEPROM
 - SD card socket
- Interfaces
 - 10/100/1000 Ethernet ports

- One Gigabit RGMII connected to Vitesse Gigabit PHY (VSC8201)
- One 5-port Vitesse Ethernet switch (VSC7385)
 - PCI and PCI Express (MPC8377E-RDB only)
- PCI Express add-in connector
- MiniPCI Express for WLAN
- One MiniPCI connector
- One standard PCI connector with extended REQ/GNT connector for riser card
 - SATA

- Two (MPC8377E) or four (MPC8379E) standard SATA II connectors
- USB 2.0
- 4-port USB hub or 1-port USB OTG
- DUART
- Thermal sensor on I²C bus
- Programmable LEDs for debug use
- Mini-ITX form factor: 170 mm x 170 mm
- 6-layer PCB routing (4-layer signals, 2-layer power and ground)
- Lead-free (ROHS), CE and FCC Certification

MPC8377E-RDB and MPC8379E-RDB Block Diagram

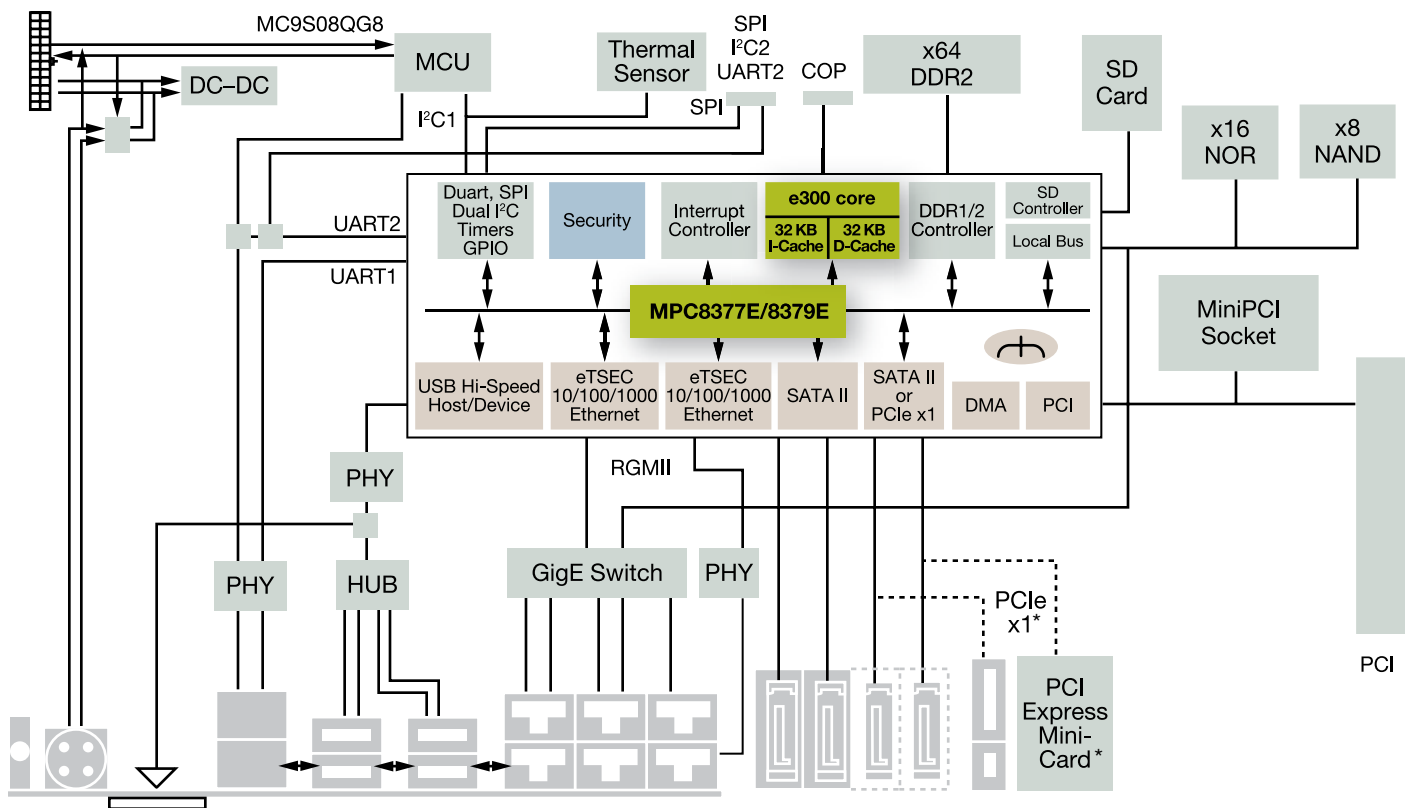

■ Core ■ Accelerators ■ I/O

* MPC8377E-RDB only

Learn More:

For current information about Freescale products and documentation, please visit www.freescale.com.



Freescale and the Freescale logo are trademarks or registered trademarks of Freescale Semiconductor, Inc. in the U.S. and other countries. All other product or service names are the property of their respective owners. The Power Architecture and Power.org word marks and the Power and Power.org logos and related marks are trademarks and service marks licensed by Power.org. © Freescale Semiconductor, Inc. 2008.

Document Number: MPC8379ERDBFS
REV 1

