

To use I2C port, the FLASH programming serial port must be disconnected.
 The debug serial port may be used if 0R resistors are fitted (Sheet 2)
 A17 may be disconnected from the SRAM (Sheet 4) allowing the pin to be used for SCI2.

SIZE A4				
HITSACHI MICRO SYSTEMS EUROPE LTD Whitebrook Park, Maidenhead, Berkshire UNITED KINGDOM				
SCHEMATIC TITLE				
EDK 2638 For Evaluation Purposes				
SHEET TITLE				
Microcontroller & Specific supporting Circuitry including pin headers				
DRAWN BY	DATE	REV	DRAWING NUMBER	PAGE
A.G.M.	11-01-02	1	D003500_04	1/5

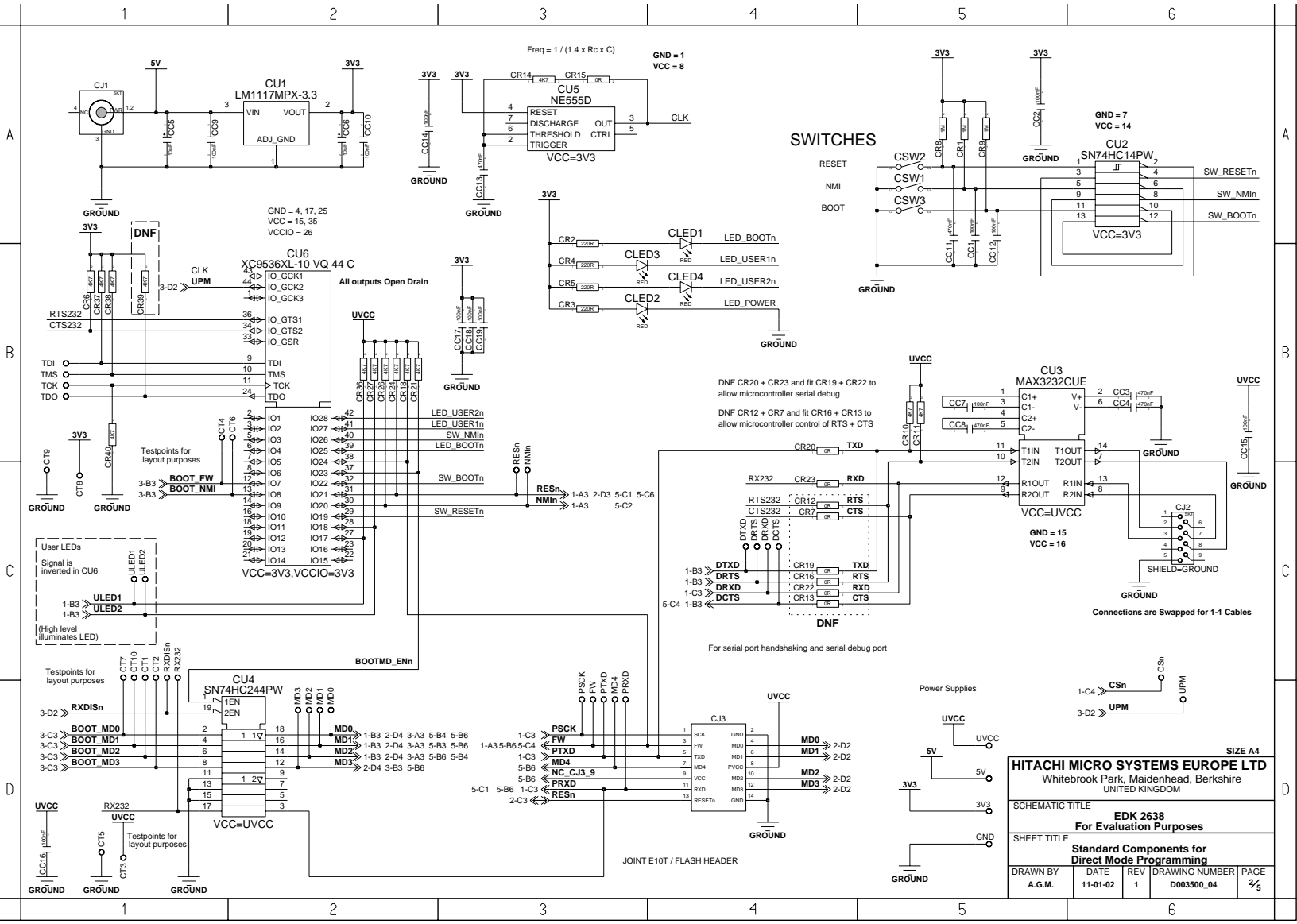

SIZE A4

HITACHI MICRO SYSTEMS EUROPE LTD
Whitebrook Park, Maidenhead, Berkshire
UNITED KINGDOM

SCHEMATIC TITLE: **EDK 2638**
For Evaluation Purposes

SHEET TITLE: **Standard Components for Direct Mode Programming**

DRAWN BY: A.G.M.	DATE: 11-01-02	REV: 1	DRAWING NUMBER: D003500_04	PAGE: 2/5
------------------	----------------	--------	----------------------------	-----------

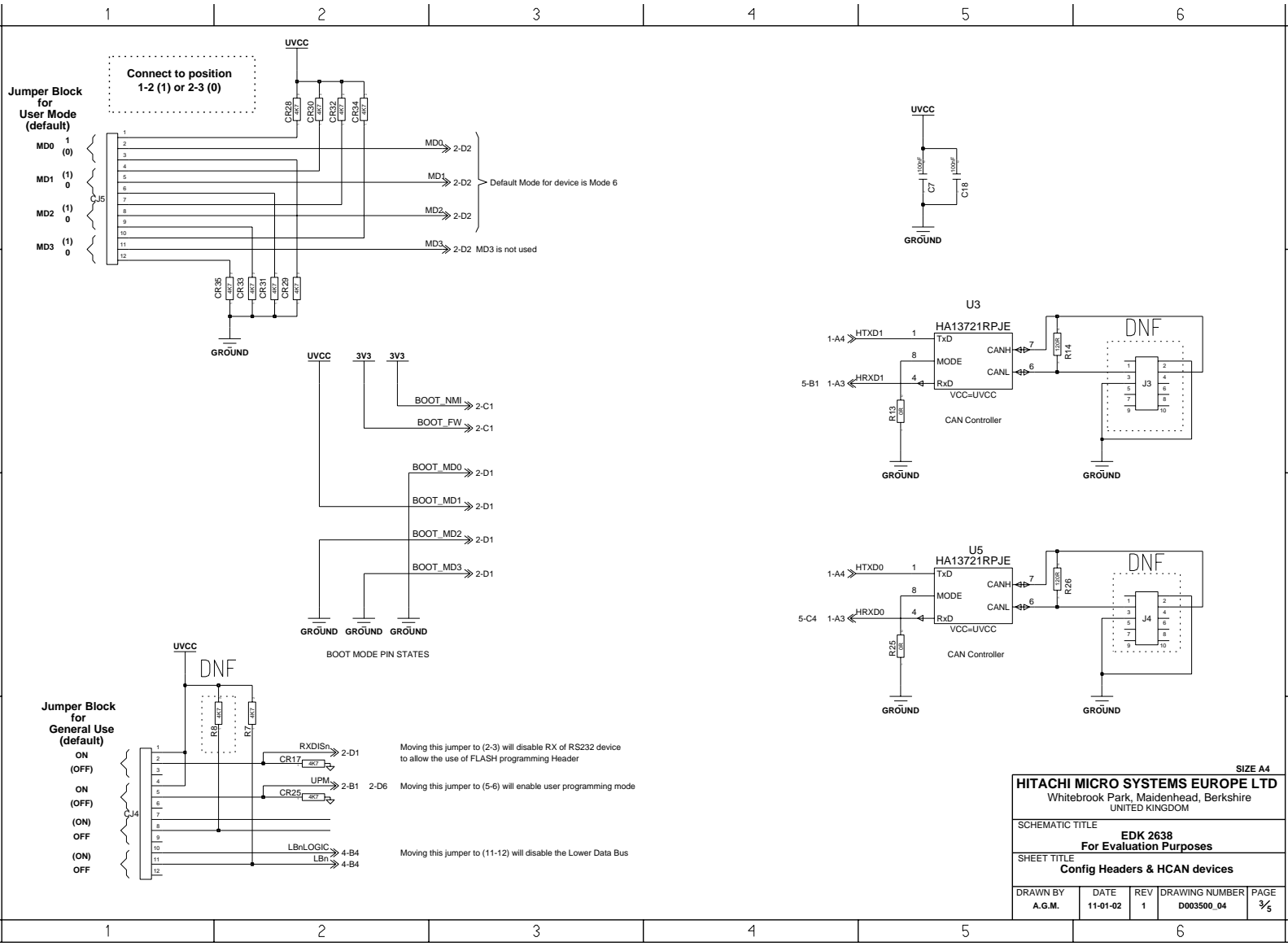

SIZE A4

HITACHI MICRO SYSTEMS EUROPE LTD
 Whitebrook Park, Maidenhead, Berkshire
 UNITED KINGDOM

SCHEMATIC TITLE: **EDK 2638**
 For Evaluation Purposes

SHEET TITLE: **Config Headers & HCAN devices**

DRAWN BY A.G.M.	DATE 11-01-02	REV 1	DRAWING NUMBER D003500_04	PAGE 3/5
--------------------	------------------	----------	------------------------------	-------------

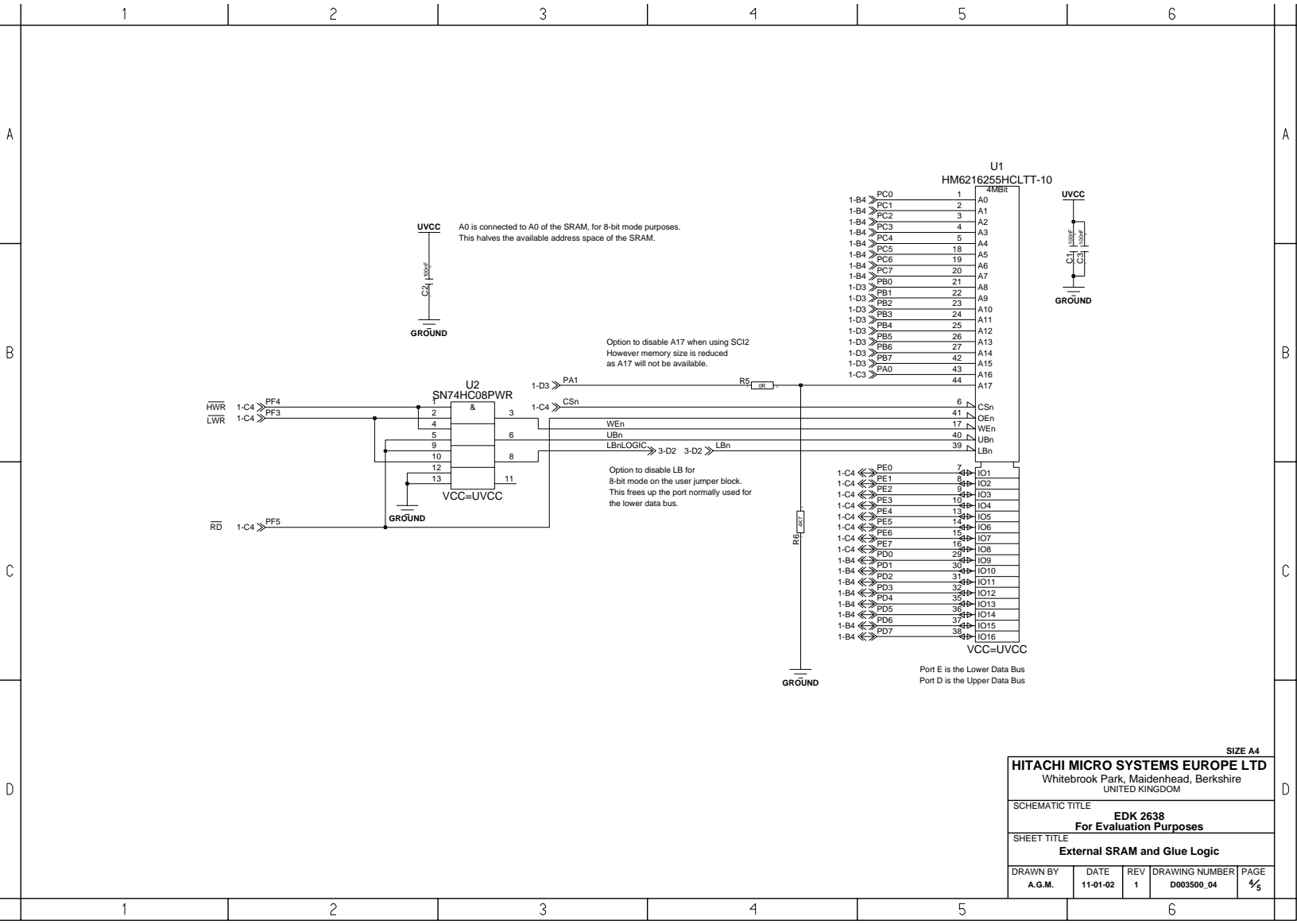

SIZE A4

HITACHI MICRO SYSTEMS EUROPE LTD
Whitebrook Park, Maidenhead, Berkshire
UNITED KINGDOM

SCHEMATIC TITLE **EDK 2638**
For Evaluation Purposes

SHEET TITLE
External SRAM and Glue Logic

DRAWN BY A.G.M.	DATE 11-01-02	REV 1	DRAWING NUMBER D003500_04	PAGE 1/5
--------------------	------------------	----------	------------------------------	-------------

Microcontroller Expansion Connector Test Points

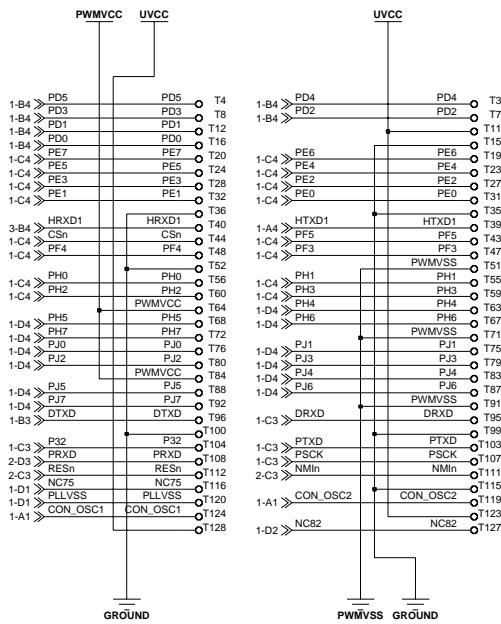

ICT Power Injection

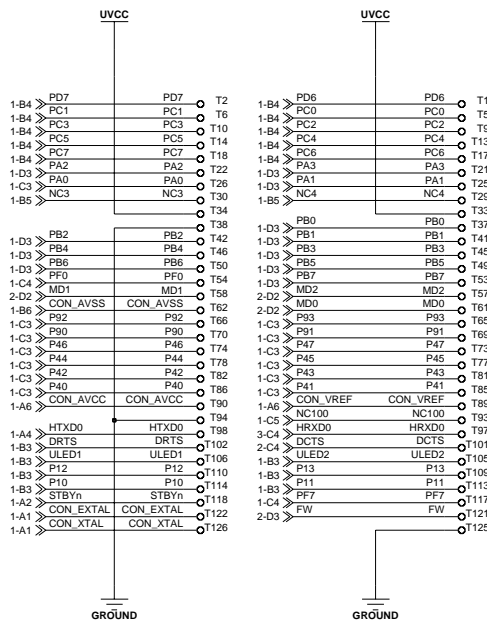

RS232 Programming Header CJ3 Testpoints

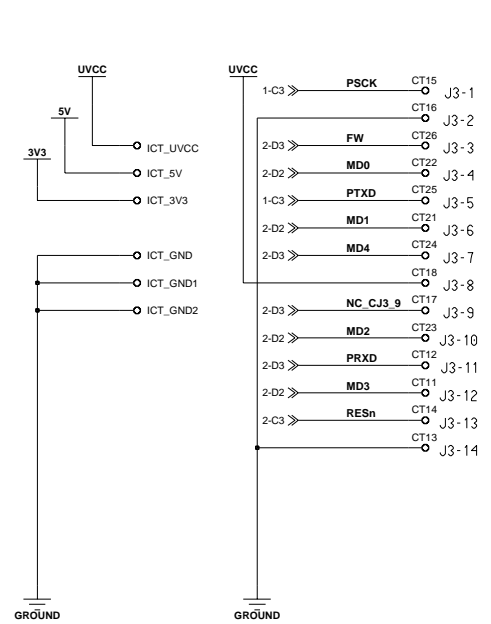

Test Points are for manufacture In-Circuit-Test ONLY

SIZE A4				
HITACHI MICRO SYSTEMS EUROPE LTD Whitebrook Park, Maidenhead, Berkshire UNITED KINGDOM				
SCHEMATIC TITLE				
EDK 2638 For Evaluation Purposes				
SHEET TITLE				
Testpoints for production test ONLY				
DRAWN BY	DATE	REV	DRAWING NUMBER	PAGE
A.G.M.	11-01-02	1	D003500_04	9/6