

**PACKING LIST - KIT CONTENTS**

**KITUSBSPIDGLEVME**  
**USB to SPI Dongle**

<u>QUANTITY</u>		<u>REVISION</u>
1	<b>770-23490: HARDWARE DOC CD, CDUSBSPIDGL</b>	3.0
	Documentation Package for KITUSBSPIDGLEVME	
	Notice	----
	Instructions	3.0
	EVB setup diagram	3.0
	Schematic Drawing	3.0
	Picture	3.0
	Assembly Drawing	3.0
	PCB - Top copper	3.0
	PCB - Bottom Copper	3.0
	Bill of Materials	3.0
	SPI Gen 5.0.1 Installation Program (setup.exe)	
	Object code for programing MCHC908JW32FC	
1	<b>700-23490: PWA, KITUSBSPIDGLEVME</b>	
1	<b>600-75489, CABLE, 6FT. USB2.0 A-M TO B-M</b>	
1	<b>920-90570-00: TECHNICAL INFORMATION CENTER FREESCALE SEMICONDUCTOR , INC. , BR1530</b>	
1	<b>920-75133: WARRANTY CARD, FREESCALE</b>	

## IMPORTANT NOTICE

**Freescale provides the enclosed product(s) under the following conditions:**

**This evaluation kit is intended for use of ENGINEERING DEVELOPMENT OR EVALUATION PURPOSES ONLY.** It is provided as a sample IC pre-soldered to a printed circuit board to make it easier to access inputs, outputs, and supply terminals. This EVB may be used with any development system or other source of I/O signals by simply connecting it to the host MCU or computer board via off-the-shelf cables. This EVB is not a Reference Design and is not intended to represent a final design recommendation for any particular application. Final device in an application will be heavily dependent on proper printed circuit board layout and heat sinking design as well as attention to supply filtering, transient suppression, and I/O signal quality.

The goods provided may not be complete in terms of required design, marketing, and or manufacturing related protective considerations, including product safety measures typically found in the end product incorporating the goods. Due to the open construction of the product, it is the user's responsibility to take any and all appropriate precautions with regard to electrostatic discharge. In order to minimize risks associated with the customers applications, adequate design and operating safeguards must be provided by the customer to minimize inherent or procedural hazards. For any safety concerns, contact Freescale sales and technical support services.

As a prototype, this product does not fall within the scope of the European Union directive on electromagnetic compatibility and therefore may not meet the technical requirements of the directive. Please be aware that the products received may not be regulatory compliant or agency certified (FCC, UL, CE, etc.).

Should this evaluation kit not meet the specifications indicated in the kit, it may be returned within 30 days from the date of delivery and will be replaced by a new kit.

Freescale reserves the right to make changes without further notice to any products herein. Freescale makes no warranty, representation or guarantee regarding the suitability of its products for any particular purpose, nor does Freescale assume any liability arising out of the application or use of any product or circuit, and specifically disclaims any and all liability, including without limitation consequential or incidental damages. "Typical" parameters can and do vary in different applications and actual performance may vary over time. All operating parameters, including "Typical", must be validated for each customer application by customer's technical experts.

Freescale does not convey any license under its patent rights nor the rights of others. Freescale products are not designed, intended, or authorized for use as components in systems intended for surgical implant into the body, or other applications intended to support or sustain life, or for any other application in which the failure of the Freescale product could create a situation where personal injury or death may occur.

Should Buyer purchase or use Freescale products for any such unintended or unauthorized application, Buyer shall indemnify and hold Freescale and its officers, employees, subsidiaries, affiliates, and distributors harmless against all claims, costs, damages, and expenses, and reasonable attorney fees arising out of, directly or indirectly, any claim of personal injury or death associated with such unintended or unauthorized use, even if such claim alleges that Freescale was negligent regarding the design or manufacture of the part.

Freescale™ and the Freescale logo are trademarks of Freescale Semiconductor, Inc. All other product or service names are the property of their respective owners. © Freescale Semiconductor, Inc. 2005

## INSTRUCTIONS

### **KITUSBSPIDGLEVME** **USB to SPI Dongle**

---

---

#### **Using the USB\_SPI Dongle**

**Warning: Always wear Safety Glasses when working around electronic modules and when soldering.**

See file USB\_SPI\_Dongle\_Information.pdf on this CD for Instructions

REVISIONS

REV	DESCRIPTION	DATE	APPROVED
3.0	ORIGINAL	2/7/2007	RCJF

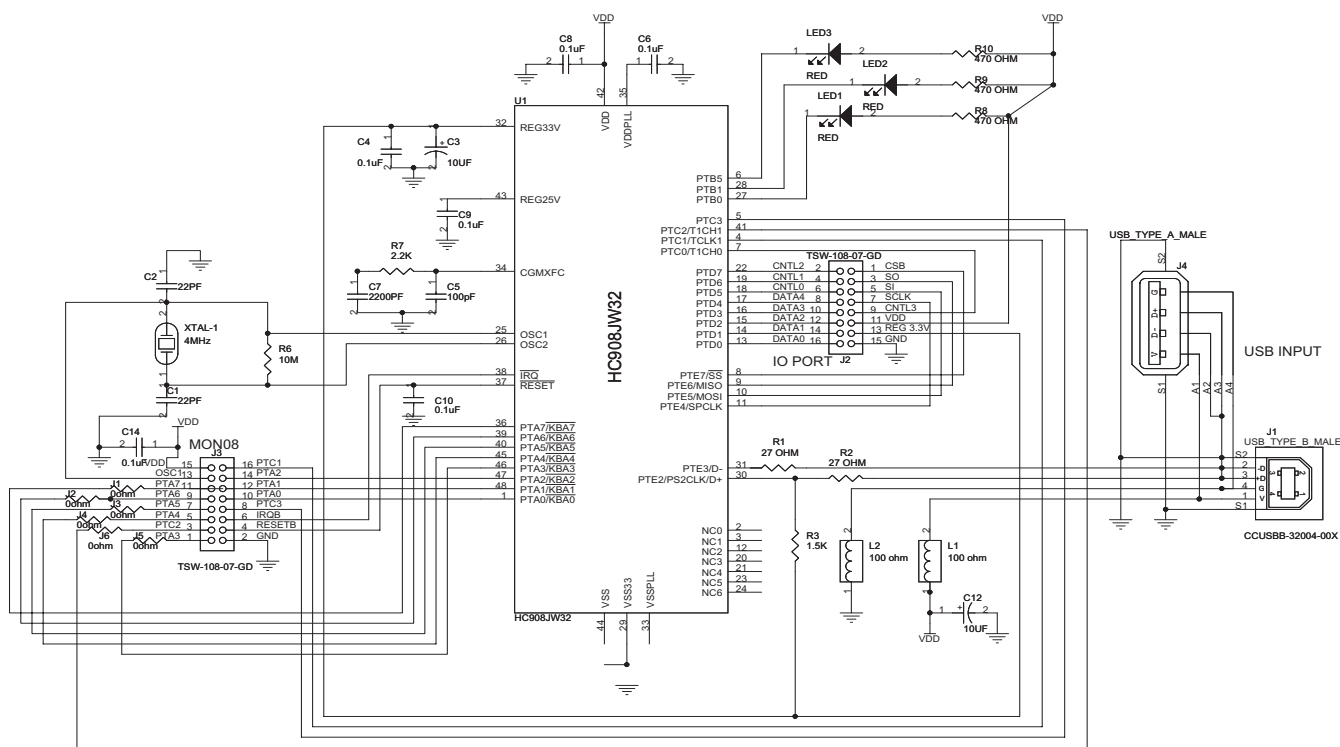

THIS DOCUMENT CONTAINS INFORMATION PROPRIETARY TO FREESCALE SEMICONDUCTOR AND SHALL NOT BE USED FOR ENGINEERING DESIGN, PROCUREMENT OR MANUFACTURE IN WHOLE OR IN PART WITHOUT CONSENT OF FREESCALE SEMICONDUCTOR.

TITLE  
**SCHUSBSPIDGLEVME SCHEMATIC**

REV  
**3.0**

REVISIONS			
REV	DESCRIPTION	DATE	APPROVED
3.0	ORIGINAL	2/7/2007	JKR

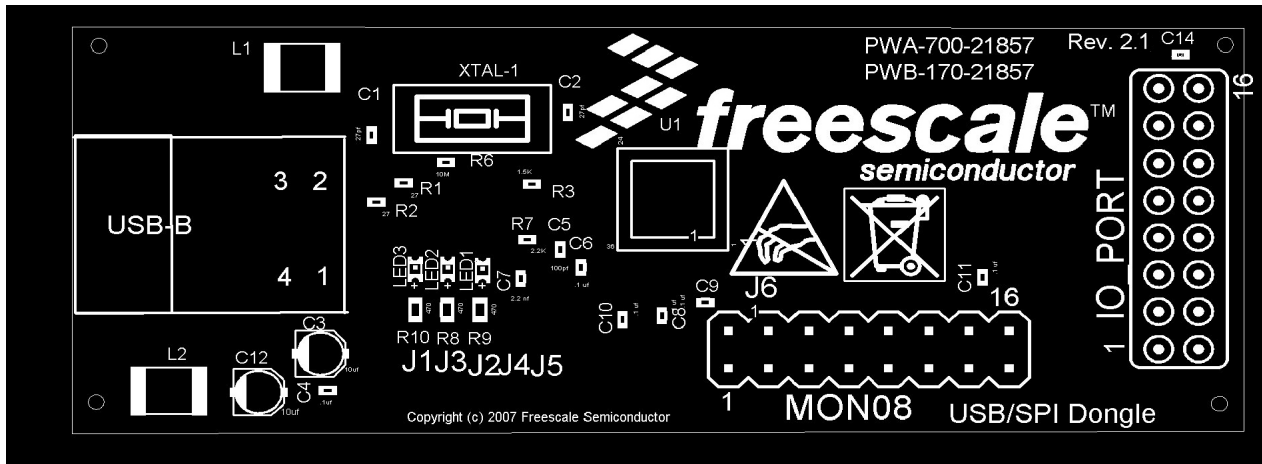

THIS DOCUMENT CONTAINS INFORMATION PROPRIETARY TO FREESCALE SEMICONDUCTOR AND SHALL NOT BE USED FOR ENGINEERING DESIGN, PROCUREMENT OR MANUFACTURE IN WHOLE OR IN PART WITHOUT CONSENT OF FREESCALE SEMICONDUCTOR.

TITLE

**KITUSBSPIDGLEVME  
ASSEMBLY DWG**

REV

3.0

REVISIONS			
REV	DESCRIPTION	DATE	APPROVED
3.0	ORIGINAL	2/7/2007	JKR

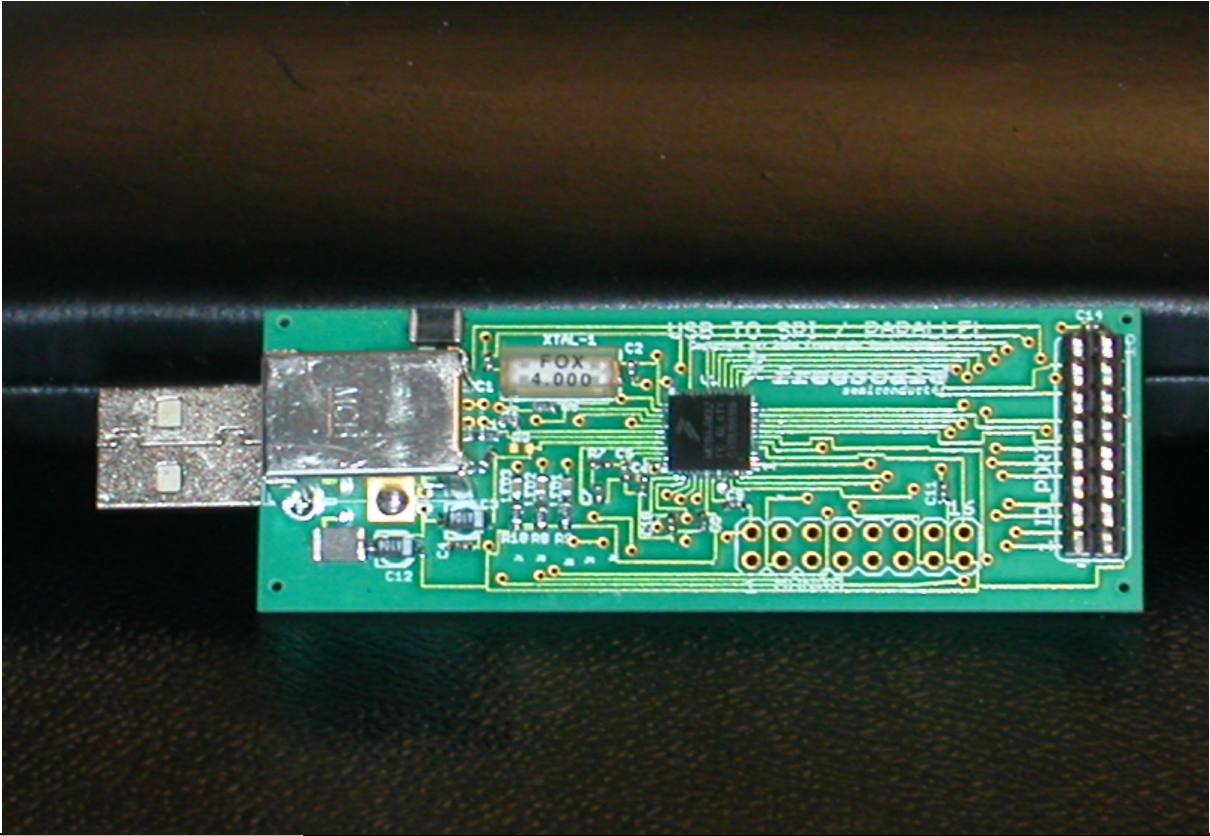

THIS DOCUMENT CONTAINS INFORMATION PROPRIETARY TO FREESCALE SEMICONDUCTOR AND SHALL NOT BE USED FOR ENGINEERING DESIGN, PROCUREMENT OR MANUFACTURE IN WHOLE OR IN PART WITHOUT CONSENT OF FREESCALE SEMICONDUCTOR.

TITLE

**KITUSBSPIDGLEVME  
ASSEMBLY DWG**

REV

3.0

REVISIONS

REV	DESCRIPTION	DATE	APPROVED
3.0	ORIGINAL	2/7/2007	RCJF

NOTES:  
1. TOP COPPER

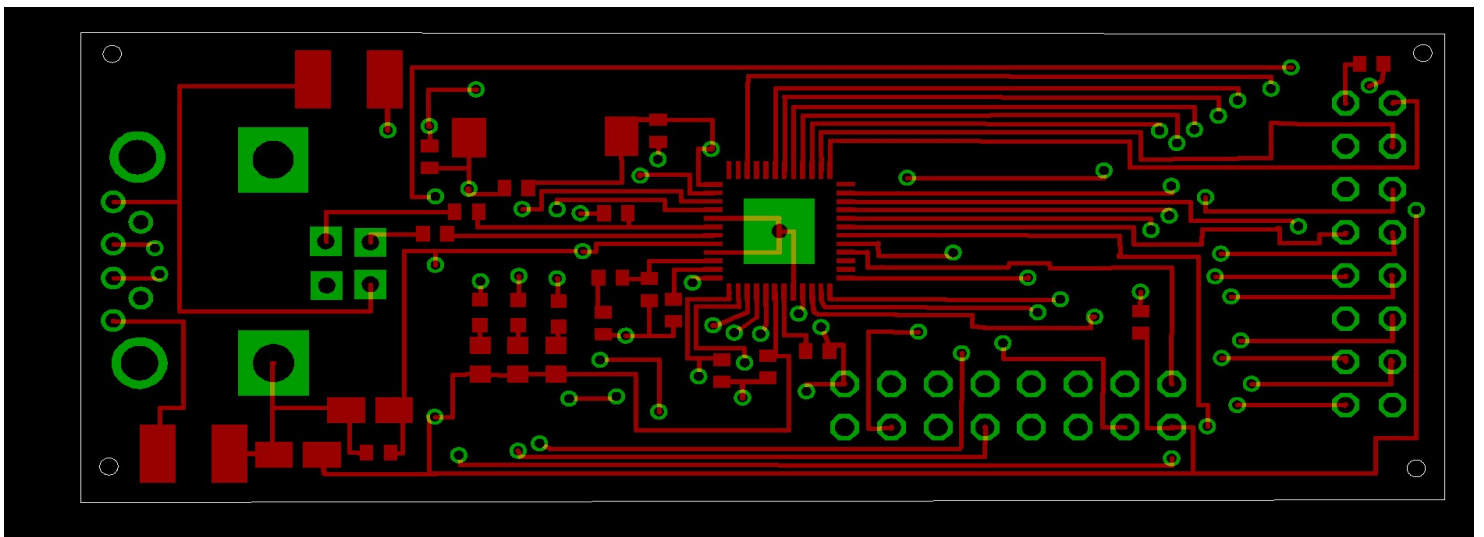

THIS DOCUMENT CONTAINS INFORMATION PROPRIETARY TO FREESCALE SEMICONDUCTOR AND SHALL NOT BE USED FOR ENGINEERING DESIGN, PROCUREMENT OR MANUFACTURE IN WHOLE OR IN PART WITHOUT CONSENT OF FREESCALE SEMICONDUCTOR.

TITLE

**PWBUSBSPIDGLEVME  
TOP COPPER**

REV

3.0

REVISIONS			
REV	DESCRIPTION	DATE	APPROVED
3.0	ORIGINAL	2/7/2007	RCJF

NOTES:  
 1. BOTTOM COPPER (AS SEEN THRU BOARD LOOKING FROM THE TOP)

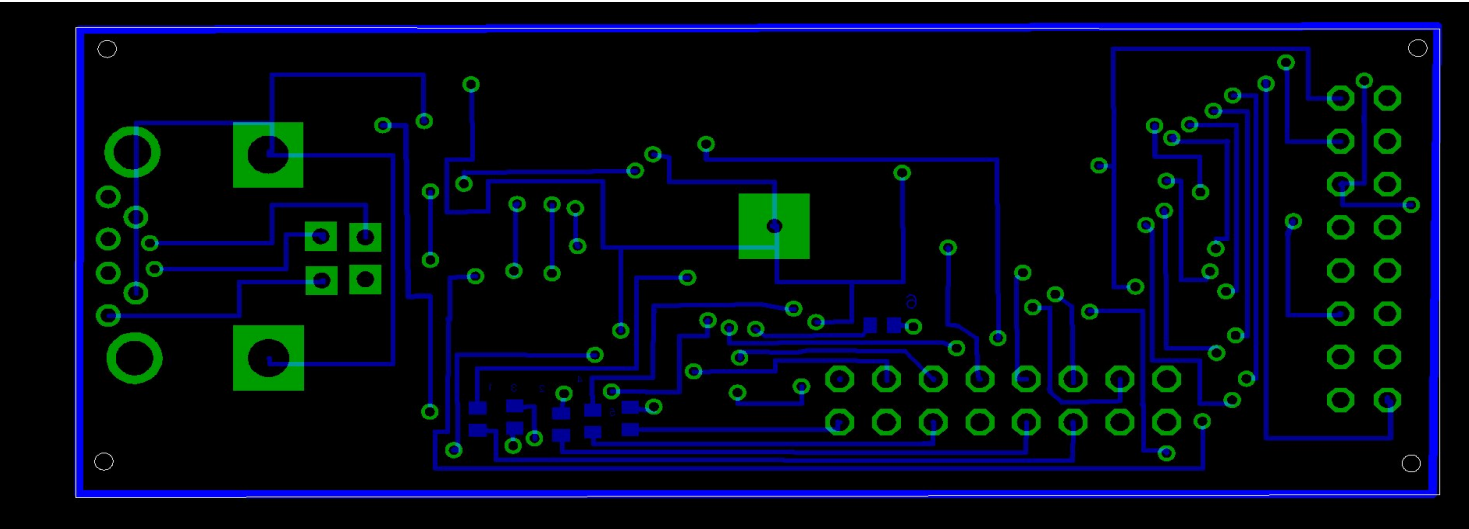

THIS DOCUMENT CONTAINS INFORMATION PROPRIETARY TO FREESCALE SEMICONDUCTOR AND SHALL NOT BE USED FOR ENGINEERING DESIGN, PROCUREMENT OR MANUFACTURE IN WHOLE OR IN PART WITHOUT CONSENT OF FREESCALE SEMICONDUCTOR.

TITLE	REV
PWBUSBSPIDGLEVME BOTTOM COPPER	3.0



## BILL OF MATERIALS

### KITUSBSPIDGLEVME

#### USB to SPI Dongle

Schematic Designation	Device or Signal Name	Agile Number	Description	Mfr. Name	Mfr. Part Number
C1	OSC2	150-75266	CAP CER 22PF 50V 5% C0G CC0402	AVX	04025A220JAT2A
C2	OSC1	150-75266	CAP CER 22PF 50V 5% C0G CC0402	AVX	04025A220JAT2A
C3	REG3.3V	150-30020	CAP TANT 10UF 10V 10% -- --	VISHAY INTERTECHNOLOGY	293D106X9010A2TE3
C4	REG3.3V	150-30007	CAP CER 0.1UF 10V 20% Y5V 0402	AVX	CM05Y5V104Z16AH
C5	CGMXFC	N/A	CAP CERAMIC 100PF 50V NP0 0402	YAGEO CORP.	CC0402JRNPO9BN101
C6	VDD PLL	150-30007	CAP CER 0.1UF 10V 20% Y5V 0402	AVX	CM05Y5V104Z16AH
C7	CGMXFC	N/A	CAP CERM .022UF 10% 16V X7R 0402	AVX	0402YC223KAT2A
C8	VDD	150-30007	CAP CER 0.1UF 10V 20% Y5V 0402	AVX	CM05Y5V104Z16AH
C9	REG2.5V	150-30007	CAP CER 0.1UF 10V 20% Y5V 0402	AVX	CM05Y5V104Z16AH
C10	RESET	150-30007	CAP CER 0.1UF 10V 20% Y5V 0402	AVX	CM05Y5V104Z16AH
C11	VDD	150-30007	CAP CER 0.1UF 10V 20% Y5V 0402	AVX	CM05Y5V104Z16AH
C12	VDD	150-30020	CAP TANT 10UF 10V 10% -- --	VISHAY INTERTECHNOLOGY	293D106X9010A2TE3
C14	VDD	150-30007	CAP CER 0.1UF 10V 20% Y5V 0402	AVX	CM05Y5V104Z16AH
R1	D+	N/A	RES 27 OHM 1/16W 5% 0402 SMD	PANASONIC ECG	ERJ-2GEJ270X
R2	D-	N/A	RES 27 OHM 1/16W 5% 0402 SMD	PANASONIC ECG	ERJ-2GEJ270X
R3	D+	470-76065	RES TF 1.5K 1/16W 1% RC0402 ROHS	BOURNS	CR0402FX1501GLF
R6	OSC1 OSC2	N/A	RESISTOR 10M OHM 1/16W 5% 0402	PANASONIC ECG	ERJ-2GEJ106X
R7	CGMXFC	N/A	RES 2.2K OHM 1/16W 5% 0402 SMD	YAGEO CORP.	RC0402JR-072K2L
R8	LED1	N/A	RES 470 OHM 1/10W 5% 0603 SMD	YAGEO CORP.	RC0603JR-07470RL
R9	LED2	N/A	RES 470 OHM 1/10W 5% 0603 SMD	YAGEO CORP.	RC0603JR-07470RL
R10	LED3	N/A	RES 470 OHM 1/10W 5% 0603 SMD	YAGEO CORP.	RC0603JR-07470RL
L1	+5V	NA	FERRITE 8A 125 OHMS 1812 SMD	STEWART	HI1812V101R-10
L2	GND	NA	FERRITE 8A 125 OHMS 1812 SMD	STEWART	HI1812V101R-10
J1	PTA7	N/A	connector	Wire jumper	
J2	PTA6	N/A	JUMPER TO CONNECT PTA6 to Pin 9 of MON08 connector	Wire jumper	
J3	PTA5	N/A	JUMPER TO CONNECT PTA5 to Pin 7 of MON08 connector	Wire jumper	
J4	PTA4	N/A	JUMPER TO CONNECT PTA4 to Pin 5 of MON08 connector	Wire jumper	

**BILL OF MATERIALS**

**KITUSBSPIDGLEVME**

**USB to SPI Dongle**

J5	PTA3	N/A	JUMPER TO CONNECT PTA3 to Pin 1 of MON08 connector	Wire jumper	
J6	PTC2	N/A	JUMPER TO CONNECT PTC2 to Pin 3 of MON08 connector	Wire jumper	
U1	MICRO	NA	MCHC908JW32FC 8 bit USB/SPI microcontroller ROHS COMPLIANT	FREESCALE SEMICONDUCTOR	MC68HC908JW32
LED1	LED1	N/A	LED 660NM RED DIFF 0603 SMD	AVAGO TECHNOLOGIES US INC.	HSMH-C190
LED2	LED2	N/A	LED 660NM RED DIFF 0603 SMD	AVAGO TECHNOLOGIES US INC.	HSMH-C190
LED3	LED3	N/A	LED 660NM RED DIFF 0603 SMD	AVAGO TECHNOLOGIES US INC.	HSMH-C190
IO PORT	MA08-2	N/A	CONN HEADER .100 DUAL STR 16POS	3M CORP	929665-02-08-I
MON08	MA08-2	N/A	CONN HEADER .100 DUAL STR 16POS	3M CORP	929665-02-08-I
XTAL-1	OSC1 OSC2	230-75423	CRYSTAL 4.0 MHZ 20PF SMD	FOX ELECTRONICS	FQ1045A-4
USB-A	USB-A Input	N/A	USB-A Male PC Board mount	SPARK FUN ELECTRONICS	PType-USB-A
USB-B	USB-B Input	N/A	CONN USB RT ANG RECPT TYPE B BLK	MOLEX/WALDOM ELECTRONICS CORP	67068-8000