

Analog Peripherals

10-Bit ADC

- ± 1 LSB INL; no missing codes
- Programmable throughput up to 200 ksp/s
- Up to 21 external inputs; programmable as single-ended or differential
- Data-dependent windowed interrupt generator
- Built-in temperature sensor (± 3 °C)

Two Comparators

- Programmable hysteresis and response time
- Configurable to generate interrupts or reset
- Low current (0.4 μ A)

POR/Brown-out Detector

On-Chip Debug

- On-chip debug circuitry facilitates full speed, non-intrusive in-system debug (no emulator required)
- Provides breakpoints, single stepping
- Inspect/modify memory and registers
- Superior performance to emulation systems using ICE-chips, target pods, and sockets

Supply Voltage: 2.7 to 3.6 V

- Typical Operating Current: 7 mA at 25 MHz
15 μ A at 32 kHz
- Typical Stop Mode Current: <0.1 μ A

High-Speed 8051 μ C Core

- Pipelined instruction architecture; executes 70% of instructions in 1 or 2 system clocks
- Up to 25 MIPS throughput with 25 MHz system clock
- Expanded interrupt handler

Memory

- 1280 bytes data RAM
- 16 kB Flash; in-system programmable in 512-byte sectors (512 bytes are reserved)

Digital Peripherals

- 29 port I/O; all are 5 V tolerant
- Hardware SMBus™ (I2C™ compatible), SPI™, and UART serial ports available concurrently
- Programmable 16-bit counter/timer array with five capture/compare modules, WDT
- 4 general-purpose 16-bit counter/timers
- Realtime clock mode using timer or PCA

Clock Sources

- Internal oscillator: 24.5 MHz, 2% accuracy supports UART operation
- External oscillator: Crystal, RC, C, or Clock (1 or 2 pin modes)
- Can switch between clock sources on-the-fly

32-Pin LQFP

Temperature Range: -40 to $+85$ °C

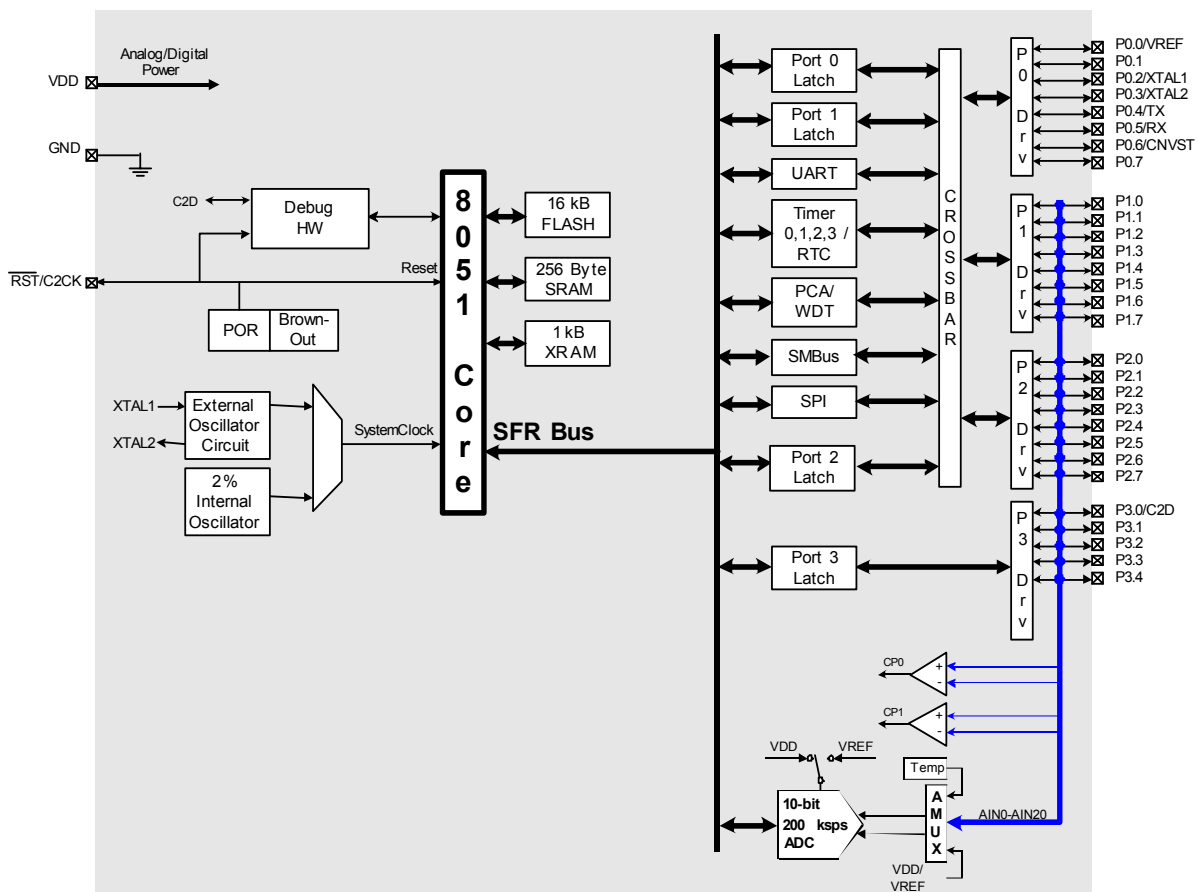

Selected Electrical Specifications

($T_A = -40$ to $+85$ °C, $V_{DD} = 2.7$ V unless otherwise specified)

PARAMETER	CONDITIONS	MIN	TYP	MAX	UNITS
GLOBAL CHARACTERISTICS					
Supply Voltage		2.7		3.6	V
Supply Current	Clock = 25 MHz		7		mA
	Clock = 1 MHz		0.5		mA
	Clock = 32 kHz; V_{DD} Monitor Disabled		15		μ A
Supply Current (shutdown)	Oscillator off; V_{DD} Monitor Enabled		10		μ A
	Oscillator off; V_{DD} Monitor Disabled		<0.1		μ A
Clock Frequency Range		DC		25	MHz
INTERNAL OSCILLATOR					
Frequency		24.0	24.5	25.0	MHz
A/D CONVERTER					
Resolution			10		bits
Integral Nonlinearity				± 1	LSB
Differential Nonlinearity	Guaranteed Monotonic			± 1	LSB
Signal-to-Noise Plus Distortion		53			dB
Throughput Rate				200	ksps
COMPARATORS					
Mode0 Response Time	(CP+) – (CP-) = 100 mV		0.10		μ s
Mode0 Supply Current			7.6		μ A
Mode1 Response Time	(CP+) – (CP-) = 100 mV		0.18		μ s
Mode1 Supply Current			3.2		μ A
Mode2 Response Time	(CP+) – (CP-) = 100 mV		0.32		μ s
Mode2 Supply Current			1.3		μ A
Mode3 Response Time	(CP+) – (CP-) = 100 mV		1.0		μ s
Mode3 Supply Current			0.40		μ A

Package Information

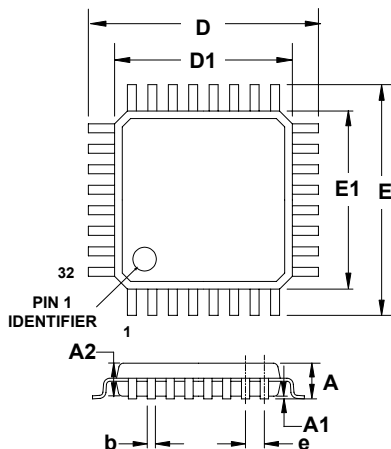

	MIN (mm)	NOM (mm)	MAX (mm)
A	-	-	1.60
A1	0.05	-	0.15
A2	1.35	1.40	1.45
b	0.30	0.37	0.45
D	-	9.00	-
D1	-	7.00	-
e	-	0.80	-
E	-	9.00	-
E1	-	7.00	-

C8051F310DK Development Kit

