

# *Hardware Specification*

*Single Board Computer SBC-i.MX51*

*...maximum performance at minimum space*

## Contact

Bluetechnix Mechatronische Systeme GmbH

Waidhausenstraße 3/19

A-1140 Vienna

AUSTRIA/EUROPE

[office@bluetechnix.at](mailto:office@bluetechnix.at)

<http://www.bluetechnix.com>

Document No.: 100-4110-1.2

Document Revision 1

Date: 2010-03-01

## Table of Contents

1	Overview .....	4
1.1	Overall Features .....	4
1.2	SBC-i.MX51 Block Diagram.....	4
1.3	Available extensions .....	5
2	SBC-i.MX51x.....	6
2.1	Main Components .....	6
2.2	Interfaces.....	6
2.2.1	Audio.....	6
2.2.2	Ethernet .....	6
2.2.3	HDMI .....	6
2.2.4	JTAG.....	6
2.2.5	SDHC-Card .....	6
2.2.6	TV-Out .....	6
2.2.7	USB/UART .....	6
2.2.8	USB .....	7
2.2.9	USB-OTG.....	7
3	Digital Video Extension Connector.....	8
3.1	Camera Sensor Interface Port .....	8
3.2	LCD Port.....	8
4	GPIO/Automation Extension Connector.....	9

# 1 Overview

## 1.1 Overall Features

The Single-Board Computer SBC-i.MX51 – also named i.fly - is based upon Freescale’s high-performance i.MX51x mobile platform, incorporating an ARM Cortex A8 CPU, an Image Processing Unit (IPUv3EX) and a Video Processing Unit (VPU). The IPUv3EX provides comprehensive support for the connectivity to displays and cameras. The VPU supports hardware encoding and decoding of MPPEG-4, H.263 or H.264 standards. Its memory capabilities (NAND Flash, DDR2 SDRAM, and SDHC) and numerous interfaces turn the SBC-i.MX51 into the ultimate development board for high-end embedded devices comparable to netbooks. Target applications include industrial automation and control systems as well as applications making use of the extensive video features.

## 1.2 SBC-i.MX51 Block Diagram

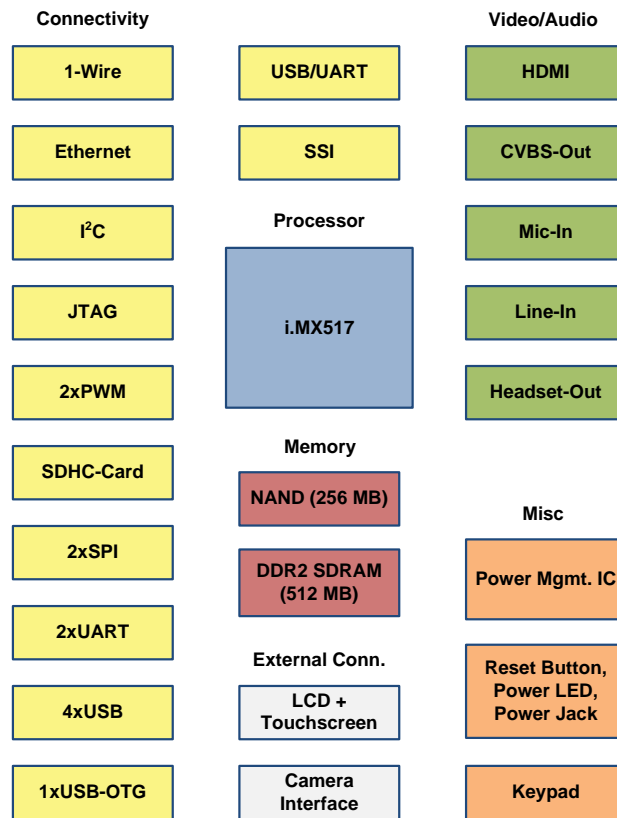

Figure 1 - Overview of the main components

### 1.3 Available extensions

In addition, different extensions boards from Bluetechnix are available. Further boards are added based on the number of customer demands. All specifications you need to design a custom board of your own are freely available so you can start your design right away. Bluetechnix also offers design support for your custom extensions. The following extensions are currently planned and will be available soon.

- ADP-SBC-i.MX51-DISP
  - OLED Port
  - Camera Sensor Interface Port (suitable for e.g. OmniVision OV2655)
- ADP-SBC-i.MX51-COMM
  - GPS
  - GSM/UMTS
  - Bluetooth
  - CAN
- ADP-SBC-i.MX51-EXP
  - Experimental board making every pin on the extension board available on a test point (allows for rapid prototyping)
- ADP-SBC-i.MX51-AUTO
  - SPI, I<sup>2</sup>C, 1-Wire
  - SSI
  - UARTs
  - GPIOs, LEDs, PWM
  - Keypad
  - Analog inputs

## 2 SBC-i.MX51x

### 2.1 Main Components

- Processor (Freescale **i.MX51x**)
- Power Management IC (Freescale **MC13892VK**)
- 2GB NAND Flash (Micron **MT29F16G08CBABAWP-IT**)
- 512MB DDR2 SDRAM (4x1Gbit Micron **MT47H64M16HR25ITG**)
- Ethernet PHY (Micrel **KSZ8041NLI**)
- Audio Codec (Freescale **SGTL5000XNA**)
- HDMI/DVI Transmitter (Analog Devices **AD9889BBB**)
- USB/UART Bridge (Silicon Labs **CP2102**)
- USB PHY (SMSC **USB3317**)
- USB HUB (SMSC **USB2514**)

The board can be supplied with 7 – 12VDC.

### 2.2 Interfaces

The following section lists all interfaces available on the board.

#### 2.2.1 Audio

The audio interface is used to deliver a standard PC audio interface with Microphone-In, Line- In and Line-Out. Standard 3,5mm audio jacks are used. A Headset can be connected to the Microphone-In and Line-Out connectors.

#### 2.2.2 Ethernet

The FEC interface of the SBC- i.MX51x is connected via an Ethernet PHY transceiver to a LAN connector. This Ethernet connection supports both 10 and 100 Mbps Ethernet/IEEE 802.3 networks.

#### 2.2.3 HDMI

A HDMI connector provides a standard interface for digital video and audio signals. The HDMI/DVI transmitter is preprocessing the video signal from the IPU. The audio signals are derived from the AUD6 interface of the i.MX51x.

#### 2.2.4 JTAG

A standard ARM JTAG connector with 20 pins is available for debugging.

#### 2.2.5 SDHC-Card

The SDHC-Card signals are directly connected to the SD1 Port of the SBC- i.MX51x. A standard SD-Card connector mounted on the bottom of the board supports SD- and SDHC cards.

#### 2.2.6 TV-Out

A cinch connector allows the transmission of a CVBS signal to a TV set.

#### 2.2.7 USB/UART

The UART1 is connected to a SiLabs CP2102, which implements the USB/UART interface. An USB-B connector is available.

### **2.2.8 USB**

The USBH1 port of the SBC-i.MX51x is connected to the USB PHY (SMSC USB3317) and further to an USB HUB (SMSC USB2514). Consequently the board features 4 standard USB-A connectors.

### **2.2.9 USB-OTG**

The i.MX51x' USB-OTG controller is connected to the internal USB PHY, which is routed to a mini USB-A/B connector.

### 3 Digital Video Extension Connector

The Video Extension Connector allows customers to design their own Video extension with user-defined camera and display components. A 60-pin-0.8-pitch stacking connector is used.

#### 3.1 Camera Sensor Interface Port

A camera (e.g. an OmniVision OV2640 or OV2655) can be connected to the SBC-i.MX51x board using the CMOS Sensor Interface 1 (CSI1).

Width (bit)	Interface	Description
10	CSI1	CSI1.D0 - CSI1.D9
5	CSI1	CSI1.VSYNC, CSI1.HSYNC, CSI1.PIXCLK, CSI1.MCLK, CSI1.PWDN
2	I <sup>2</sup> C2	I2C2.SDA, I2C2.SCL - Camera control interface
15	Power	P_5V0, P_GEN3_2V9, P_SW4_1V8, P_DIG_1V25, P_CAM_2V75, GND

#### 3.2 LCD Port

The DISP2 interface is available to connect an LCD display and a touch screen to the SBC-i.MX51x board. The i.MX51x supports display resolutions up to 1280X720.

Width (bit)	Interface	Description
16	DISP2	DISP2.D0 – DISP2.D15
4	DISP2	DISP2.VSYNC, DISP2.HSYNC, DISP2.CLK, DISP2.DE
2	PWM	PWM1, TFT.PWRCTRL - Contrast
2	LED	P_SWLED, LED.MD - Display Backlight
4	ADIN	ADIN[1..4] – Touch screen
15	Power	P_5V0, P_GEN3_2V9, P_SW4_1V8, P_DIG_1V25, P_CAM_2V75, GND



## 4 GPIO/Automation Extension Connector

The GPIO / Automation Extension Connector allows customers to design their own GPIO extension with user-defined components. A 60-pin-0.8-pitch stacking connector is used. Most interfaces have alternate functions and can also be used as GPIOs.

Interface	Width (bit)	Interface	Description
1-Wire	1	OWIRE	OWIRE
Analog-In	3	ADIN	ADIN[5..7]
I2C	2	I2C1	I2C1.SCL, I2C1.SDA
Keypad	10	KPP	KPP.COL[0..5], KPP.ROW[0..3]
LEDs	3		P_SWLED, LED.AD, LED.KP
PWM	2	PWM1, PWM2	PWM1, PWM2
SD	6	SD2	SD2.CMD, SD2.CLK, SD2.D0, SD2.D1, SD2.D2, SD2.D3
SPI	6	CSPI1	CSPI1.MOSI, CSPI1.MISO, CSPI1.SS0, CSPI1.SS1, CSPI1.RDY, CSPI1.SCLK
SSI	6	AUD4	AUD4.RFS, AUD4.RSCK, AUD4.Tx, AUD4.Rx, AUD4.TSCK, AUD4.TFS
UART	4	UART2, UART3	UART2.TXD, UART2.RXD UART3.TXD, UART3.RXD
Power	16		P_GEN2_3V15, P_5V0, P_EXT_3V, P_MLB_2V5, P_SW4_1V8, GND
Power down	1		A_CTRL.PON1