

XK-1 Development Board Quick Start Guide

Version 1.1



Publication Date: 2010/05/10

Copyright © 2010 XMOS Ltd. All Rights Reserved.

1 Introduction

The XK-1 is a low cost development board intended for exploring event-driven processor designs. It comprises a single XS1-L1 device, 128KBytes SPI FLASH memory, four LEDs and two press-button switches. Two XSYS Connectors let you link multiple XK-1 boards together in a chain and two banks of 0.1" IDC connectors are provided for connecting additional components to the XK-1. An XTAG-2 debug adapter can be used to connect the XK-1 to a USB 2.0 port on a PC, providing a JTAG interface that can be used to load and debug programs on the board. The XK-1 can be powered directly from the XTAG-2 debug adapter or from an external 5V power supply.

To program the XK-1 you need to download a set of free Development Tools from the XMOS website. The tools let you write, load and debug programs on your development board using the XTAG-2.

Further information on using the XK-1 and additional resources including the development tools is available from <http://www.xmos.com/xk1>.

2 XK-1 Demos

A set of demonstrations is pre-installed on the XK-1 board which you can use to test the hardware. Additional demonstrations can be downloaded from the XMOS web site, including an XK-1 tutorial which introduces the key concepts you need to understand when programming the XK-1 board.

We recommend that you install the XMOS Development Tools before you connect the XK-1 to your development system—see Section 3.

1. Connect the 20-way IDC header on the XTAG-2 to the left XSYS connector on the XK-1 board.
2. Plug the XTAG-2 into a USB 2.0 connector on your development system.
The XK-1 board starts up and flashes the four LEDs in sequence across the top of the board.
3. Press **Switch A** on the XK-1 to increase the speed that the LEDs flash.
4. Press **Switch B** to change the order that the LEDs flash.

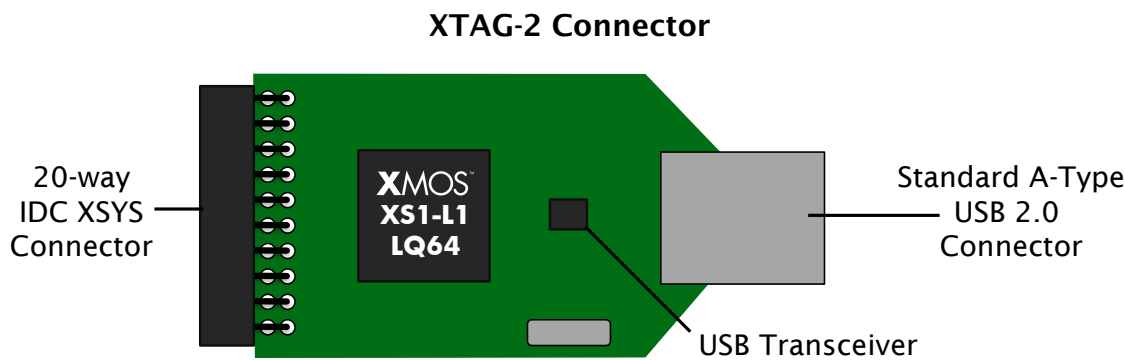
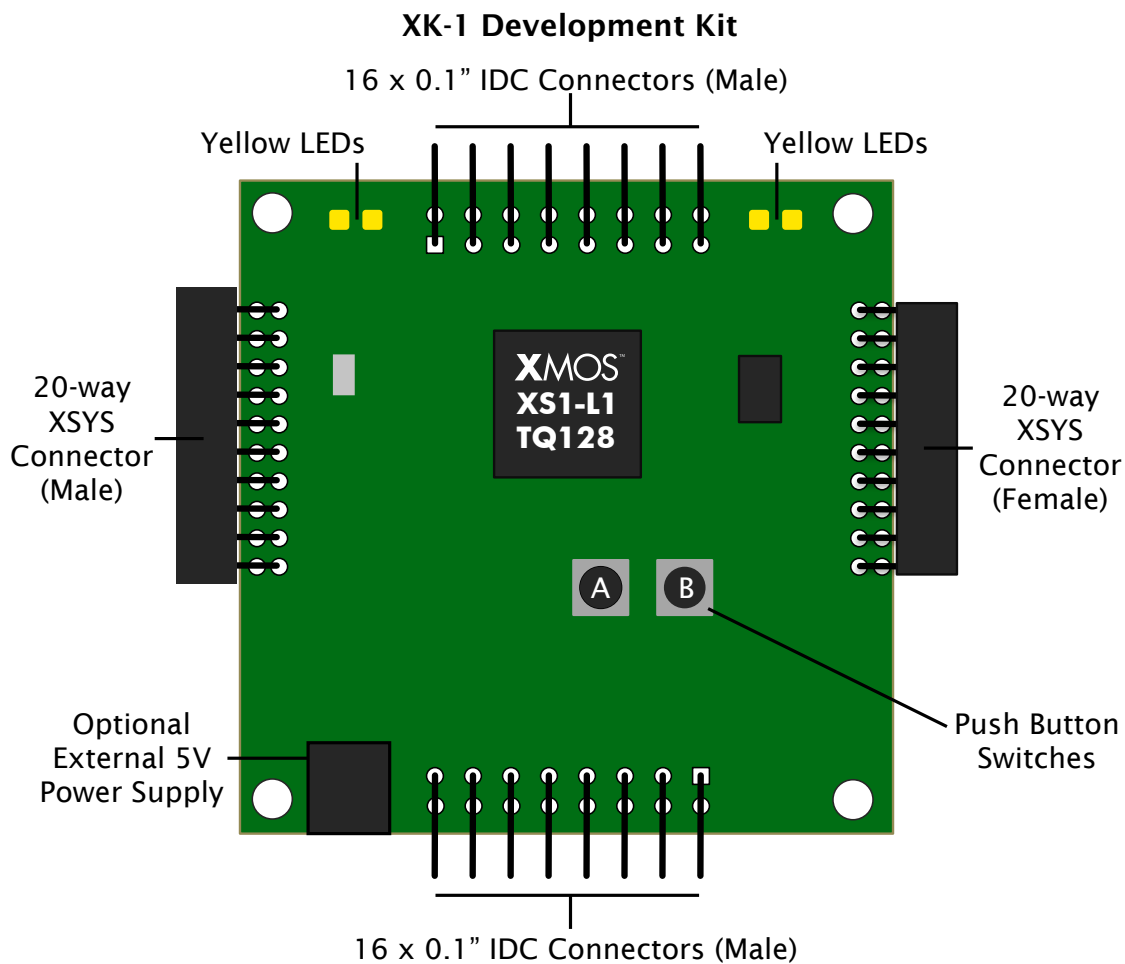

3 XMOS Tools Support

The XMOS Development Tools are provide in a single platform-specific downloadable file from

<http://www.xmos.com/tools>

Instructions on installing and using the XMOS Tools can be found in the XMOS Tools User Guide http://www.xmos.com/published/xtools_en. The following table provides a summary tools support for the XK-1 development board.

Minimum tools version required	9.9
Board support file	XK-1.xn
USB-to-JTAG adaptor	XTAG-2
USB-to-JTAG driver	XMOS
Board Tutorial	Integrated into XDE and available as PDF
Hardware Guide	http://www.xmos.com/published/xk1hw

4 Document History

Date	Release	Comment
2009-11-03	1.0	First release
2010-05-10	1.1	Added tools support section

Disclaimer

XMOS Ltd. is the owner or licensee of this design, code, or Information (collectively, the "Information") and is providing it to you "AS IS" with no warranty of any kind, express or implied and shall have no liability in relation to its use. XMOS Ltd. makes no representation that the Information, or any particular implementation thereof, is or will be free from any claims of infringement and again, shall have no liability in relation to any such claims.

Copyright © 2010 XMOS Ltd. All Rights Reserved. XMOS and the XMOS logo are registered trademarks of XMOS Ltd in the United Kingdom and other countries, and may not be used without written permission. Company and product names mentioned in this document are the trademarks or registered trademarks of their respective owners. Where those designations appear in this document, and XMOS was aware of a trademark claim, the designations have been printed with initial capital letters or in all capitals.