

MPC8536DS

Integrated media and communications processor development system

Overview

The MPC8536E Development System (MPC8536DS) is ideal for hardware and software development for embedded applications. It leverages Freescale's highly integrated MPC8536E processor, built on Power Architecture® technology, and leading-edge external components.

The high level of integration in the MPC8536E processor helps to lower system costs, improve performance and simplify board design. The MPC8536E processor supports:

- Dual-enhanced three-speed Ethernet controllers (eTSEC) with IEEE® 1588 Rev 2 support
- Multiple PCI Express® ports supporting one x8, two x4, or one x4 and two x2 link widths
- 32-bit PCI controller
- Advanced power management controller
- Three integrated USB controllers
- Two integrated SATA controllers
- Enhanced Serial Peripheral Interface (eSPI)
- Enhanced Secure Digital Hardware Controller (eSDHC)
- 4-channel direct memory access (DMA)
- Dual universal asynchronous receiver/transmitter (DUART)
- Serial peripherals
- General purpose I/O
- System timers

The MPC8536E processor also integrates an optional hardware encryption block that supports different algorithms for high-performance data that is critical for supporting secure communications. Devices marked with an E include this security engine.

A board support package (BSP) is pre-installed on the MPC8536DS. This BSP consists of a boot loader (u-boot) and a generic Power Architecture technology system based on the Linux® kernel. The u-boot binary and the Linux kernel reside in the on-board flash memory with a file system pre-installed on the hard disk shipped in the MPC8536DS development system.

The MPC8536DS BSP generation takes advantage of the Linux Target Image Builder (LTIB), a suite of tools that leverages existing open source configuration scripts and source code packages, packing them all into a single BSP generation bundle. The source code packages include boot loader and Linux kernel sources as well as many user-space source code packages to build a complete BSP. The LTIB also provides compiler packages, required to build the BSP. Freescale developers use the LTIB to create BSPs for a multitude of Freescale development markets. The LTIB leverages as many BSP elements as possible for the Freescale markets supported, while offering the flexibility necessary to customize components that require platform-specific modifications.

Many third-party applications are available for the MPC8536DS. They are typically built on top of the BSP delivered by Freescale and can be installed on the hard disk. To see demonstrations or to acquire details of Freescale's third-party applications for this platform, please contact your local Freescale sales office.

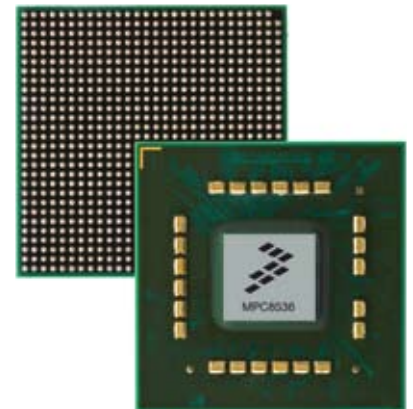

MPC8536DS Block Diagram

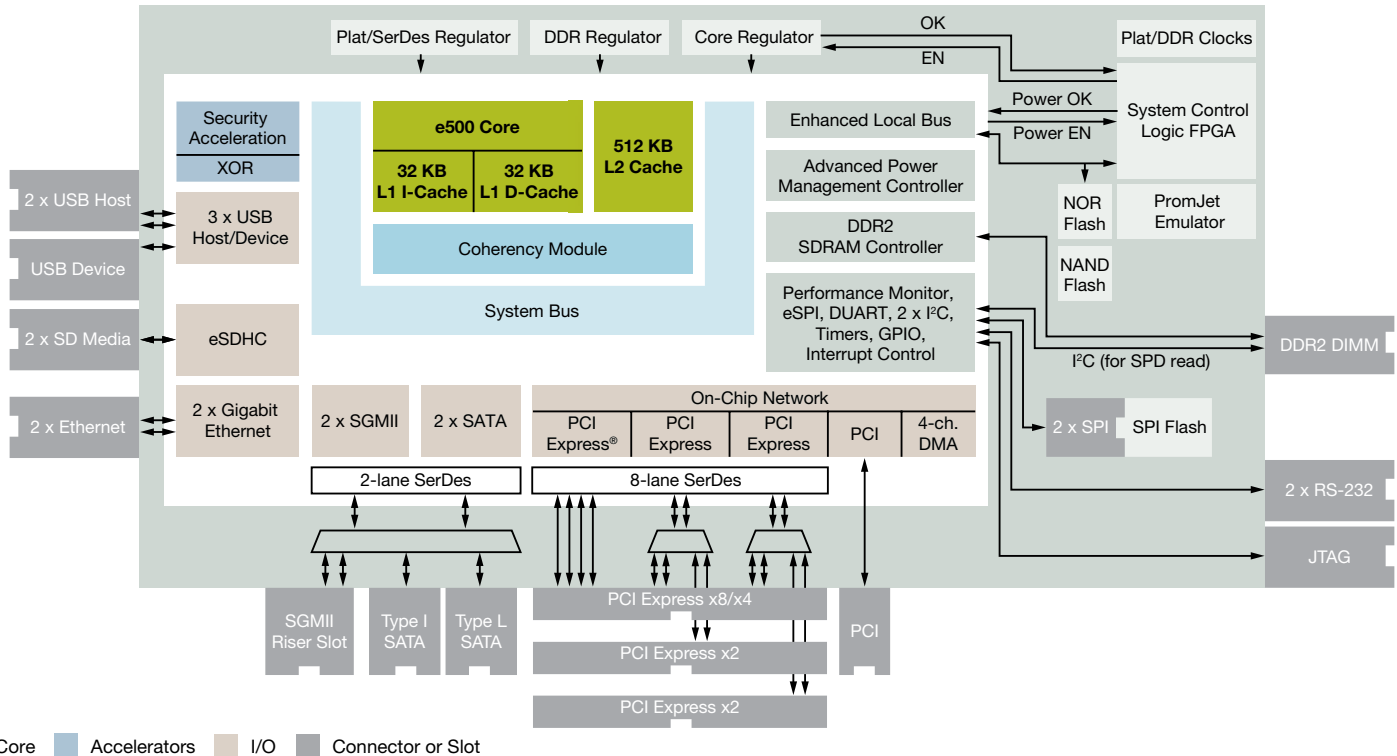

MPC8536E Development System



- MPC8536E PowerQUICC® III processor

- 512 MB DDR2 DIMM
- Two SATA connectors (Type I and Type L)
- Three PCI Express slots
- One PCI slot with dynamic support of 33 MHz and 66 MHz cards
- Three USB connectors (two host and one device)
- Two SD media slots
- Four eSPI EEPROMs (64 MB total)
- Two 10/100/1000 Ethernet connectors

- SGMII riser card slot (SGMII-RISER)
- Real-time clock
- Two RS232 connectors
- JTAG header
- 128 MB NOR flash memory
- 4 GB NAND flash memory
- Power and temperature monitoring circuitry
- System logic (FPGA)
 - Manages system reset sequencing
 - Manages system bus and PCI clock speed selections
 - Implements registers for system control and monitoring
- System clock
 - SYSCLK switch can be set to one of eight common settings in the interval 33 MHz–166 MHz
- DDR clock
 - DDRCLK switch can be set to one of eight common settings in the interval 33 MHz–166 MHz
- Power supplies
 - Dedicated regulator for VDD_VCORE (1.1V or 1.0V)
 - Dedicated regulator for VDD_PLAT (1.0V)
- Documentation
 - Reference manual
 - Schematics
 - Bill of materials
 - Board errata
 - Configuration guide
- Software tools
 - Linux 2.6.x kernel
 - Cross compile and native GNU tool chain
 - CodeWarrior™ USB TAP

Learn More:

For current information about Freescale products and documentation, please visit www.freescale.com.



Freescale and the Freescale logo are trademarks or registered trademarks of Freescale Semiconductor, Inc. in the U.S. and other countries. All other product or service names are the property of their respective owners. The Power Architecture and Power.org word marks and the Power and Power.org logos and related marks are trademarks and service marks licensed by Power.org. © Freescale Semiconductor, Inc. 2009.

Document Number: MPC8536DSFS
REV 1

