

PowerQUICC™ MPC8313E Reference Design Board (RDB)

The MPC8313E reference design board (RDB) is a system featuring the PowerQUICC™ II Pro processor, which includes a built-in security accelerator. This low-cost, high-performance system solution consists of a printed circuit board (PCB) assembly plus a software board support package (BSP) distributed in a CD image. This BSP enables the fastest possible time-to-market for development or integration of applications including printer engines, broadband gateways, no-new-wires home adapters/access points, and home automation boxes.

This document describes the hardware features of the board including specifications, block diagram, connectors, interfaces, and hardware straps. It also describes the board settings and physical connections needed to boot the MPC8313E RDB. Finally, it considers the software shipped with the platform.

When you finish reading this document, you should:

- Be familiar with the board layout
- Understand the default board configuration and your board configuration options
- Know how to get started and boot the board
- Know about the software and further documentation that supports the board

Contents

1. MPC8313E RDB Hardware	2
2. Board-Level Functions	7
3. Connectors, Jumpers, Switches, and LEDs	19
4. Micro-Jumper/Resistor Options for eTSEC1	27
5. MPC8313E RDB Board Configuration	38
6. Getting Started	43
7. MPC8313E RDB Software	46
8. Frequently Asked Questions (FAQs)	47
9. Revision History	49

WARNING

This is a class A product. In a domestic environment this product may cause radio interference, in which case the user may be required to take adequate measures.

Use this manual in conjunction with the following documents:

- *MPC8313E PowerQUICC™ II Pro Integrated Communications Processor Family Reference Manual* (MPC8313ERM)
- *MPC8313E PowerQUICC II Pro Processor Hardware Specifications* (MPC8313EEC)
- “Hardware and Layout Design Considerations for DDR Memory Interfaces” (AN2582)

NOTE

The normal function of the product may be disturbed by strong electromagnetic interference. If so, simply reset the product to resume normal operation by following the instructions in the manual. If normal function does not resume, use the product in another location.

This equipment has been tested and found to comply with the limits for a Class A digital device, pursuant to Part 15 of the FCC Rules. These limits are designed to provide reasonable protection against harmful interference when the equipment is operated in a commercial environment. This equipment generates, uses, and can radiate radio frequency energy. If it is not installed and used in accordance with the instruction manual, it may cause harmful interference to radio communications. Operation of this equipment in a residential area is likely to cause harmful interference, in which case the user will be required to correct the interference at his or her own expense.

1 MPC8313E RDB Hardware

This section covers the features, block diagram, specifications, and mechanical data of the MPC8313E RDB.

1.1 Features

The board features are as follows:

- CPU: Freescale MPC8313E running at 333/166 MHz; CPU/coherent system bus (CSB)
- Memory subsystem:
 - 128 Mbyte unbuffered DDR2 SDRAM discrete devices
 - 8 Mbyte flash single-chip memory
 - 32 Mbyte NAND flash memory
 - 256 Kbit M24256 serial EEPROM
 - SD connector to interface with the SD memory card in SPI mode
- Interfaces:
 - 10/100/1000 BaseT Ethernet ports:
 - eTSEC1, RGMII: five 10/100/1000 BaseT RJ-45 interfaces using Vitesse™ VSC7385 L2 switch, or selectable one 10/100/1000 BaseT RJ-45 interface using Marvell™ 88E1111 PHY in REVC board

- eTSEC2, selectable RGMII or SGMII: one 10/100/1000 BaseT RJ-45 interface using Marvell 88E1111 PHY
- USB 2.0 port: high-speed host/device
- USB interface: selectable on-chip PHY or external ULPI PHY interface by SMSC USB3300 USB PHY
- PCI: 32-bit PCI interface running at up to 66 MHz
 - One 32-bit 3.3 V PCI slot connected to PCI bus
 - One 32-bit 3.3 V miniPCI slot connected to PCI bus
- Dual UART ports:
 - DUART interface: supports two UARTs up to 115200 bps for console display
- Board connectors:
 - LCD connectors by GPIO
 - ATX power supply connector
 - JTAG/COP for debugging
- IEEE Std. 1588™ signals for test and measurement
- Real-time clock and thermal sensor on I²C bus
- Programmable LEDs for debug use
- 6-layer PCB routing (4-layer signals, 2-layer power and ground)

Figure 1 shows the MPC8313E RDB block diagram.

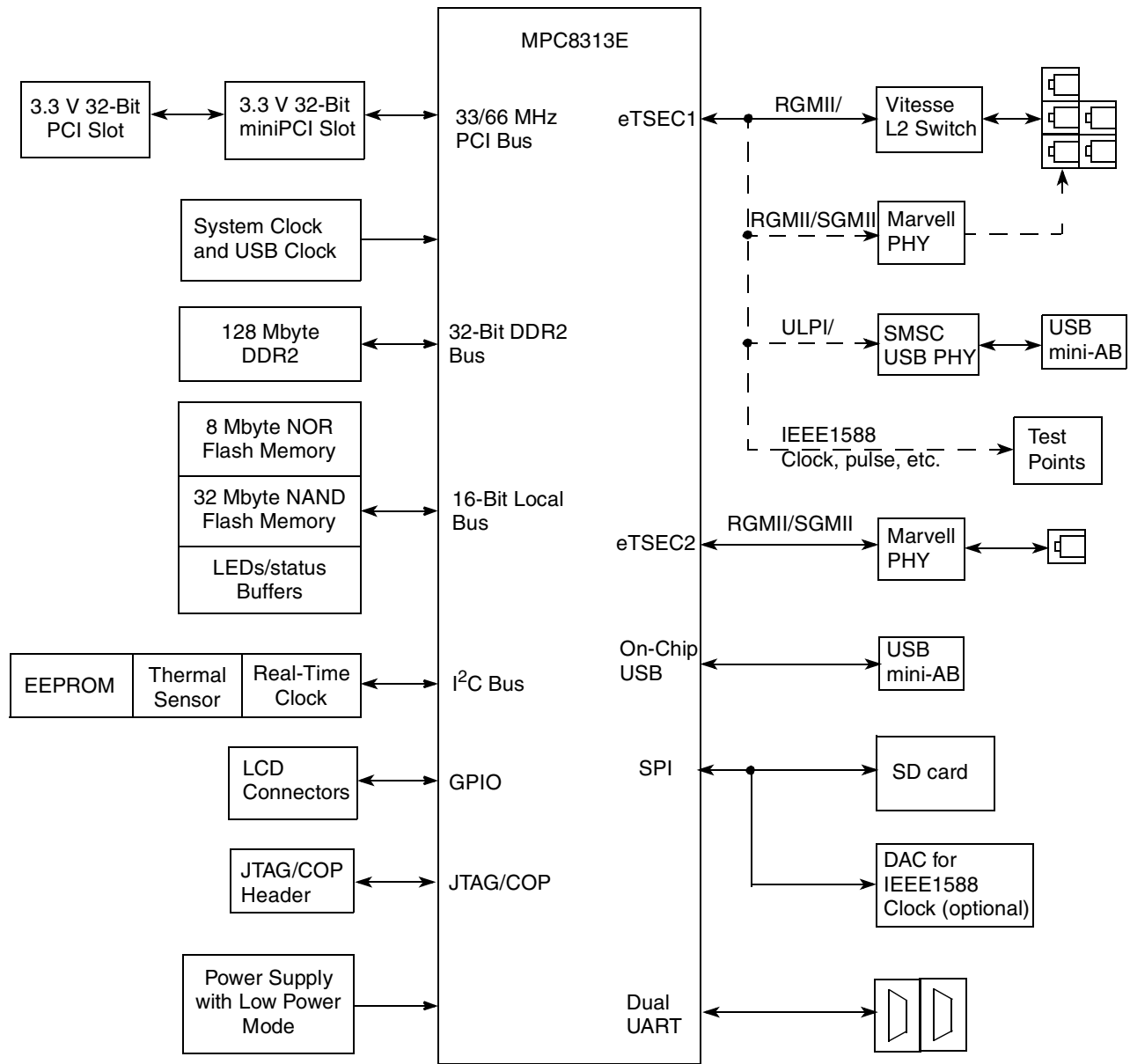

---NOTE---
 ← - - - → : selected by resistor options

Figure 1. MPC8313E RDB Block Diagram

1.2 Specifications

Table 1 lists the specifications of the MPC8313E RDB.

Table 1. MPC8313E-RDB Specifications

Characteristics	Specifications
Power requirements (without add-on card):	Typical Maximum 12 V DC 0A 0 A 5.0 V DC 1 mA 1.5 A
Communication processor	MPC8313E running at 266 MHz
Addressing: Total address range Flash memory (local bus) DDR2 SDRAM	4 Gbyte (32 address lines) 8 Mbyte with one chip-select 128 Mbyte DDR2 SDRAM
Operating temperature	0° C to 70° C (room temperature)
Storage temperature	-25° C to 85° C
Relative humidity	5% to 90% (noncondensing)
PCB dimensions: Length Width Thickness	6693 mil (REVA and REVB) or 7692 mil (REVC) 6693 mil 62 mil

1.3 Mechanical Data

Figure 2 shows the MPC8313E RDB REVx and REVb dimensions (in mil and [mm]). The board measures 170 mm × 170 mm (6693 mil × 6693 mil) for integration in a mini-ITX chassis.

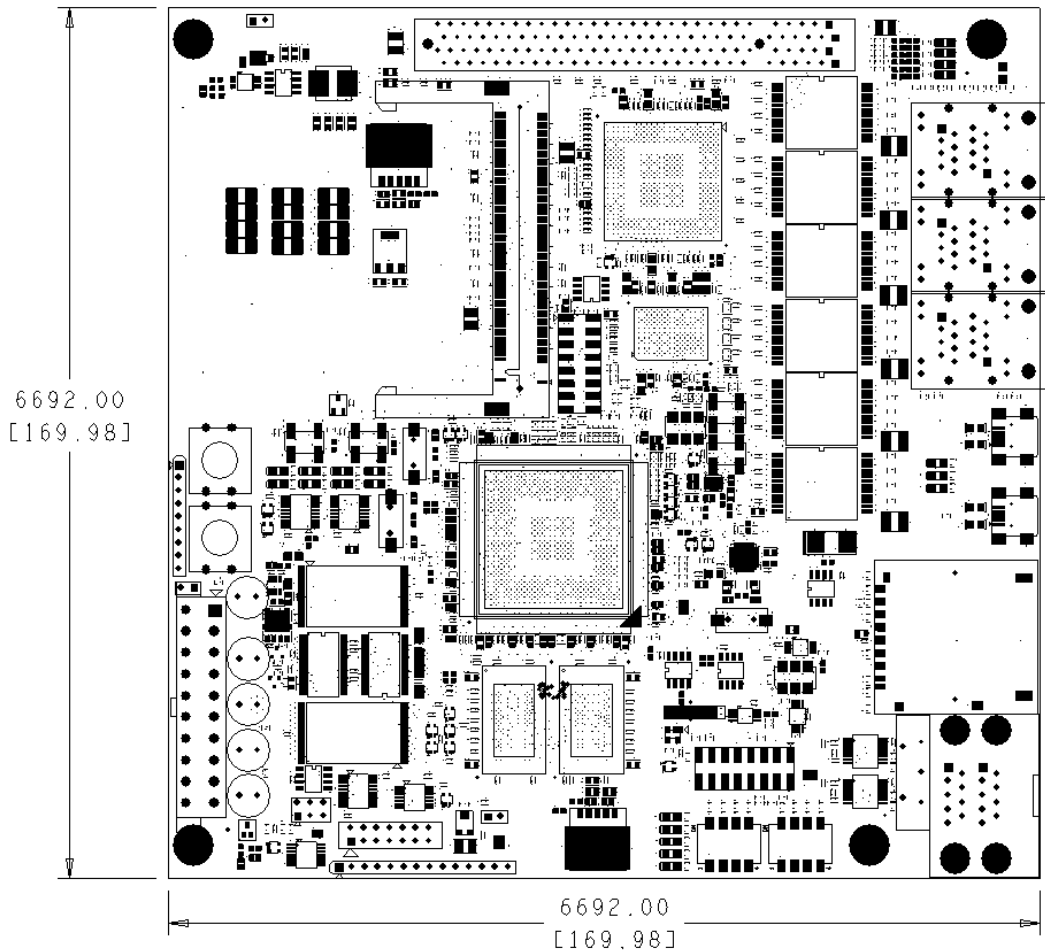

Figure 2. Dimensions of the MPC8313E RDB (REVx and REVb)

Figure 3 shows the MPC8313E RDB Rev C dimensions (in mil and [mm]). The board measures 195 mm \times 170 mm (7692 mil \times 6693 mil).

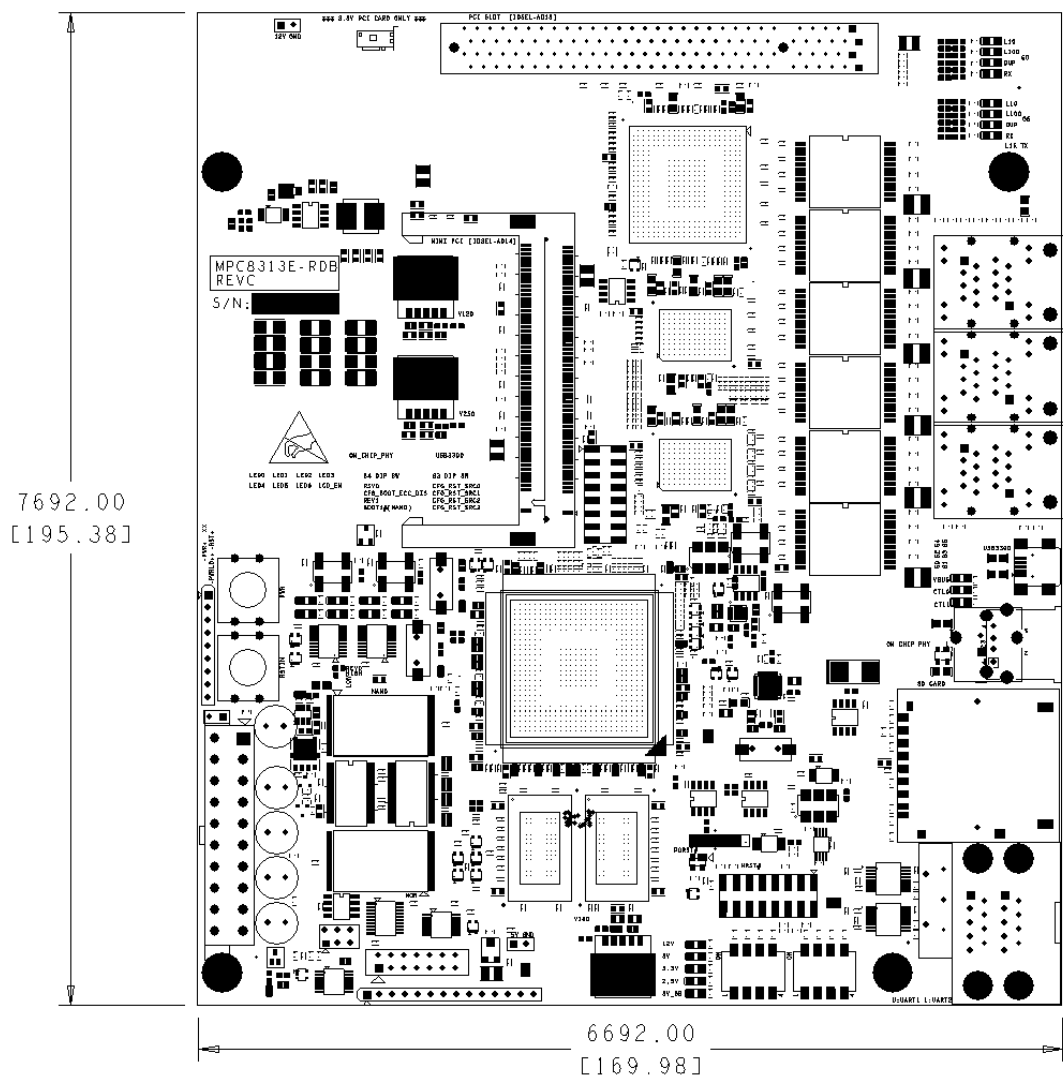

Figure 3. Dimensions of the MPC8313E RDB (REVC)

2 Board-Level Functions

The board-level functions are reset, external interrupts, clock distribution, DDR SDRAM controller, local bus controller, I²C interfaces, SD memory card interface, USB interface, eTSEC1 10/100/1000 BaseT interface, dual RS-232 ports, PCI bus, and COP/JTAG.

2.1 Reset and Reset Configurations

The MPC8313E RDB reset module generates a single reset to the MPC8313E and other peripherals on the board. The reset unit provides power-on reset, hard reset, and soft reset signals in compliance with the MPC8313E hardware specification.

Figure 4 shows the reset circuitry. Note the following:

- Hard reset is generated either by the COP/JTAG port or the MPC8313E.
- Power-on reset is generated by the Maxim MAX811 device. When \overline{MR} is deasserted and 3.3 V is ready, the MAX811 internal timeout guarantees a minimum reset active time of 150 ms before $\overline{PORESET}$ is deasserted. This circuitry guarantees a 150 ms $\overline{PORESET}$ pulse width after 3.3 V reaches the right voltage level, which meets the specification of the $\overline{PORESET}$ input of MPC8313E.
- COP/JTAG port reset provides convenient hard-reset capability for a COP/JTAG controller. The \overline{RESET} line is available at the COP/JTAG port connector. The COP/JTAG controller can directly generate the hard-reset signal by asserting this line low.
- Push button reset interfaces using the \overline{MR} signal with debounce capability to produce a manual master reset of the RDB.
- Soft reset is generated by the COP/JTAG port. Assertion of \overline{SRESET} causes the MPC8313E to abort all current internal and external transactions and set most registers to their default values.

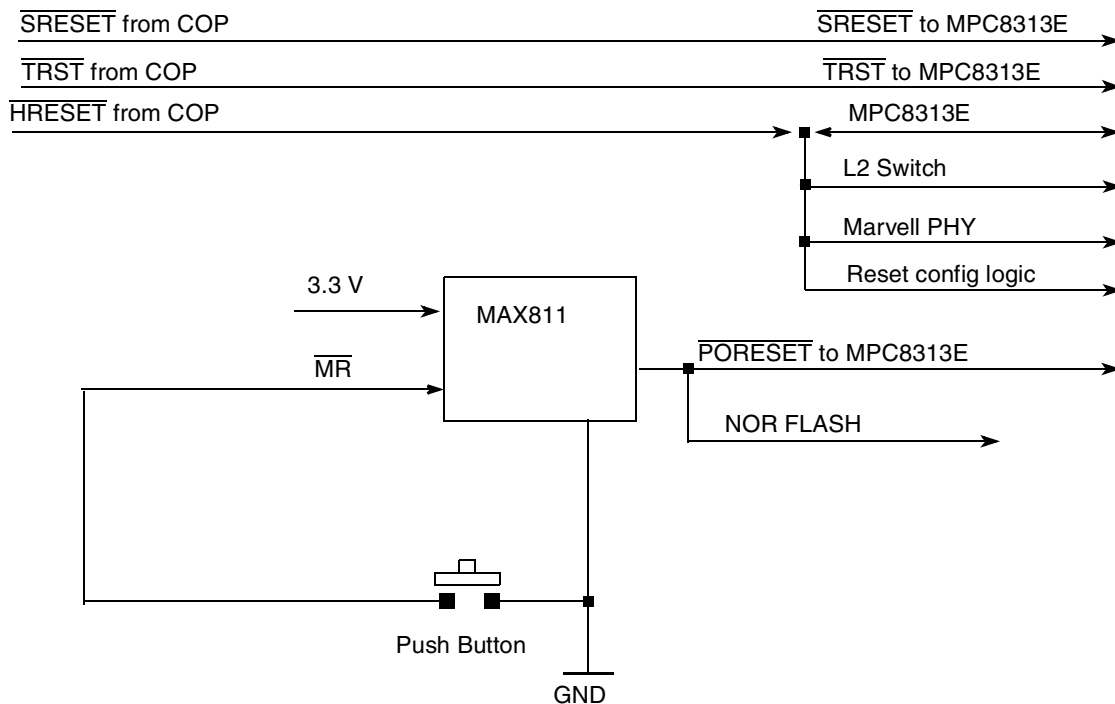

Figure 4. Reset Circuitry of the MPC8313E

2.2 External Interrupts

Figure 5 shows the external interrupts to the MPC8313E.

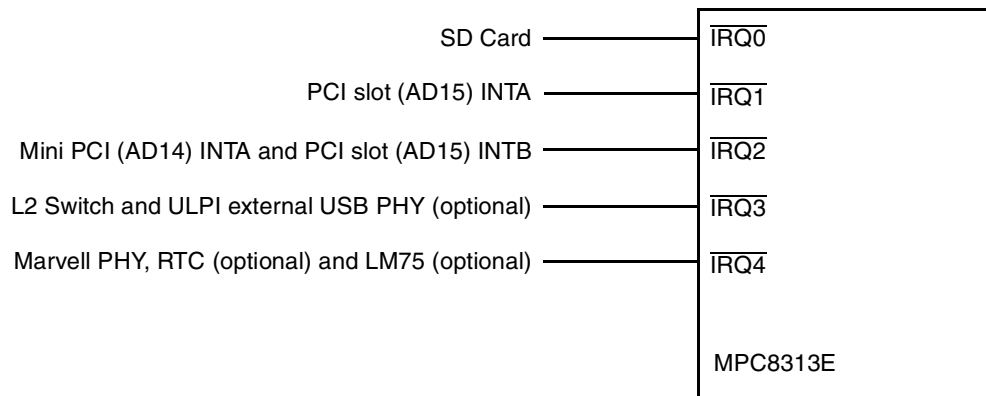

Figure 5. MPC8313E Interrupts

The following are descriptions of the interrupt signals shown in Figure 5:

- All external interrupt signals are pulled up by 4.7 K Ω resistors.
- $\overline{\text{IRQ0}}$ is connected to SD Card
- $\overline{\text{IRQ1}}$ is connected to PCI slot INTA.
- $\overline{\text{IRQ2}}$ is connected to and shared by the PCI slot's INTB and the mini PCI slot INTA.
- $\overline{\text{IRQ3}}$ is connected to the L2 switch as well as to an external USB PHY (by an optional resistor).
- $\overline{\text{IRQ4}}$ is connected to the Marvell GBE PHY as well as to RTC and LM75 (by an optional resistors).

2.3 Clock Distribution

Figure 6 and Table 2 show the clock distribution on the MPC8313E RDB.

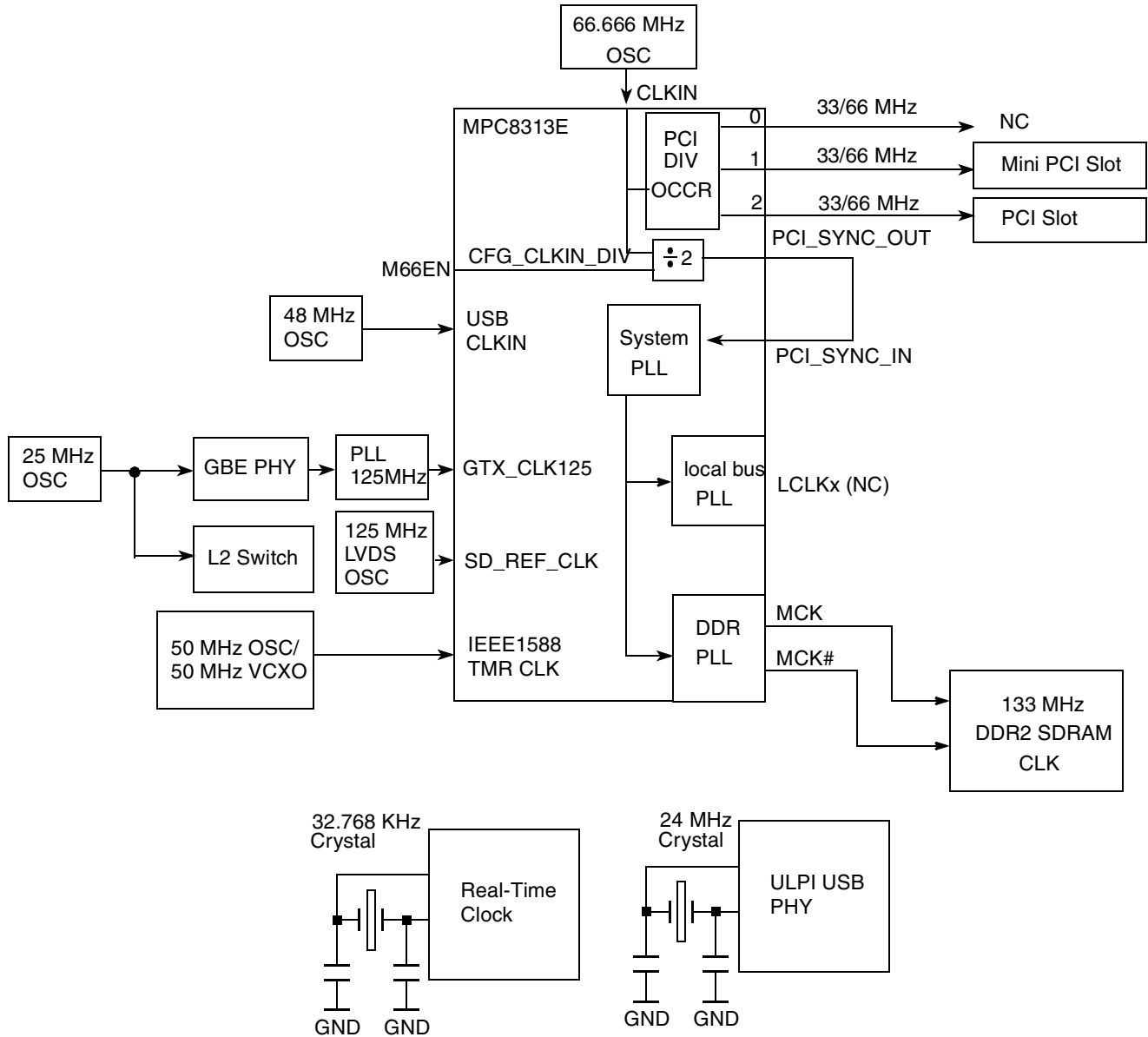

Figure 6. MPC8313E-RDB Clock Scheme

Table 2. Clock Distribution

Clock Frequency	Module	Generated by	Description
66.666 MHz	MPC8313E CLKIN	66.666 MHz oscillator	The MPC8313E uses CLKIN to generate the PCI_SYNC_OUT clock signal, which is fed back on the board through the PCI_SYNC_IN signal to the internal system PLL. From the power-on reset configuration, the CSB clock is generated by the internal PLL and is fed to the e300 core PLL for generating the e300 core clock. The CFG_CLKIN_DIV configuration input selects whether CLKIN or CLKIN/2 is driven on the PCI_SYNC_OUT signal. The CFG_CLKIN_DIV is tied to the M66EN input pin.
133 MHz	DDR2 SDRAM	MPC8313E	The DDR memory controller is configured to use the 2:1 mode CSB to DDR for the DDR interface (DDR266). The local bus clock uses 1:1 local to CSB clock, which is configured by hard reset configuration or SPMR register.
33/66 MHz	PCI 32-bit slot and MiniPCI slot	MPC8313E	The PCI module uses the PCI_SYNC_IN as its clock source. The trace length of the PCI_SYNC_IN to PCI_SYNC_OUT signal is matched with all PCI clocks on the RDB.
25 MHz	L2 Switch and GBE PHY	25 MHz oscillator	The 25 MHz oscillator provides the clock for the L2 switch and the GBE PHY
125 MHz	eTSEC clock	GBE PHY with PLL (REVC), or 125 MHz oscillators (REVB), or GBE PHY (REVAx)	The GTX_CLK125 and SERDES (SGMII) clocks are provided by external oscillators (or by GBE PHY in REVAX and REVC boards).
48 MHz	USB clock	48 MHz oscillator	48 MHz is provided for on-chip USB PHY of MPC8313E
50 MHz	IEEE1588 Clock (TMR_CLK)	50 MHz oscillator/50 MHz VCXO	50 MHz is used by the IEEE 1588 module. It can be an ordinary oscillator or VCXO controlled by SPI DAC.
24 MHz	ULPI external USB PHY	24 MHz crystal	24 MHz crystal is used by the ULPI external USB PHY
32.768 KHz	Real-time clock	32.768 KHz crystal	32.768 KHz crystal is used by the real-time clock

2.4 DDR2 SDRAM Controller

The MPC8313E processor uses DDR2 SDRAM as the system memory. The DDR2 interface uses the SSTL2 driver/receiver and 1.8 V power. A $V_{ref} 1.8 V/2$ is needed for all SSTL2 receivers in the DDR2 interface. For details on DDR2 timing design and termination, refer to the Freescale application note entitled “Hardware and Layout Design Considerations for DDR Memory Interfaces” (AN2582). Signal integrity test results show this design does not require terminating resistors (series resistor (R_S) and termination resistor (R_T)) for the discrete DDR2 devices used. DDR2 supports on-die termination; the DDR2 chips and MPC8313E are connected directly. The interface is 1.8 V provided by an on-board

voltage regulator. VREF, which is half the interface voltage, or 0.9 V, is provided by a voltage divider of 1.8 V for voltage tracking and low cost. The MPC8313E provides a pair of clock pins, which are connected and shared by the two DDR2 devices.

Figure 7 shows the DDR2 SDRAM controller connection.

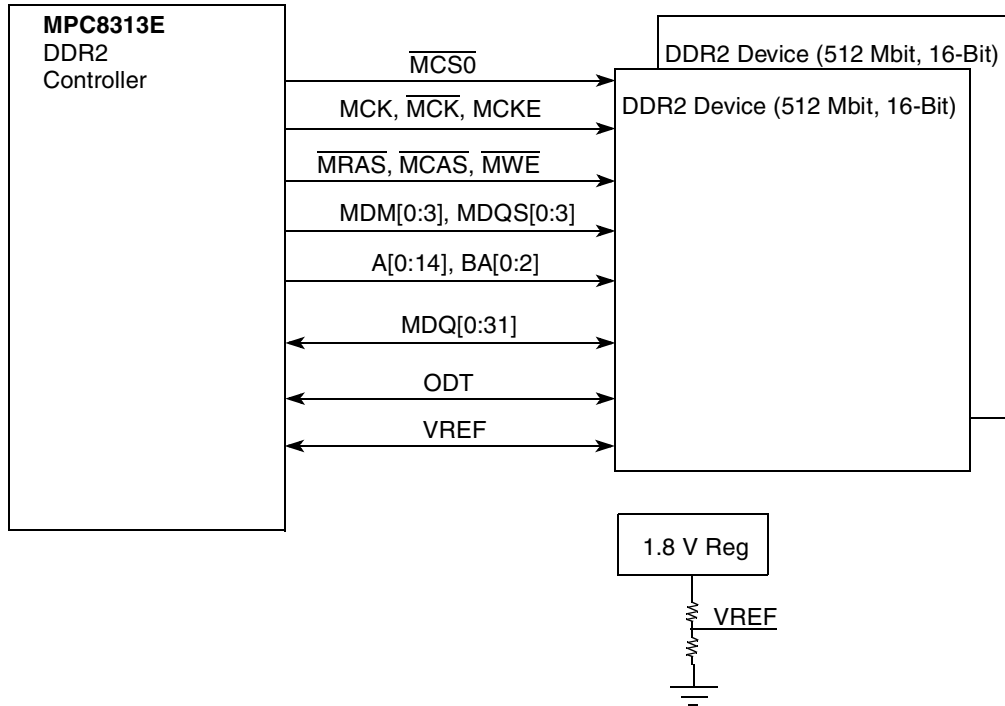

Figure 7. DDR2 SDRAM Connection

2.5 Local Bus Controller

The MPC8313E local bus controller has a 26-bit LAD[0–15] and LA[16–25] address that consists of 16-bit data multiplex bus and control signals. The local bus speed is up to 133 MHz. To interface with the standard memory device, an address latch must provide the address signals. The LALE is used as the latching signal. To reduce loading of the high speed local bus interface, a data buffer for all low-speed devices is attached to the memory controller. The followings modules are connected to the local bus:

- 8 Mbyte NOR flash memory
- 32 Mbyte NAND flash memory
- LED/status buffers

2.5.1 NOR Flash Memory

Through the general-purpose chip-select machine (GPCM), the MPC8313E RDB provides 8 Mbyte of flash memory using a chip-select signal. The flash memory is used with the 16-bit port size. Figure 8

shows the hardware connections for the flash memory. The starting address for the 8 Mbyte flash memory is 0xFE00_0000 to 0xFE7F_FFFF.

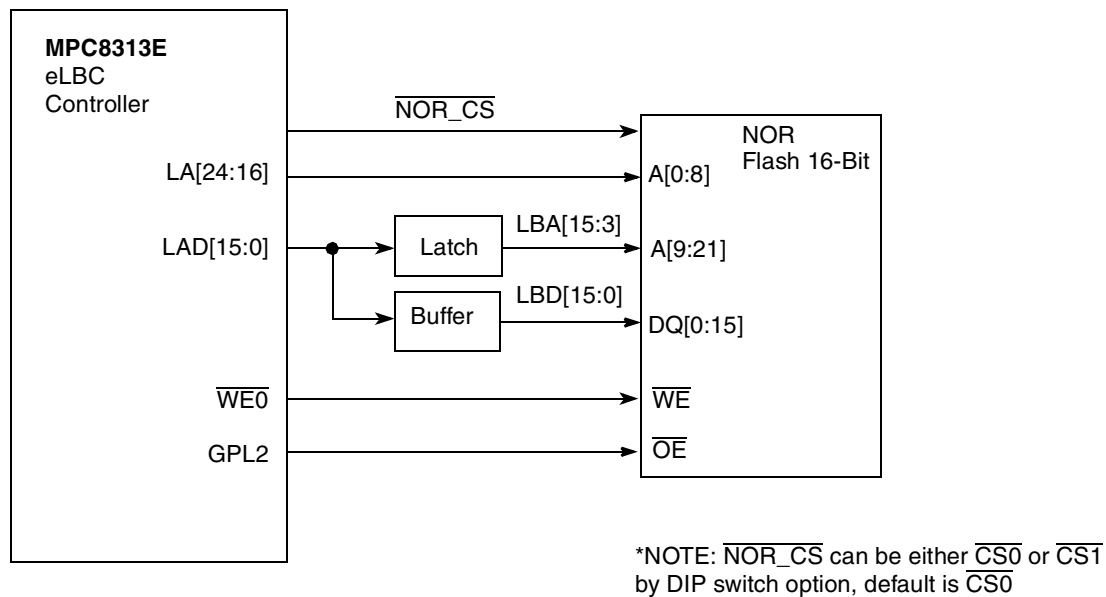

Figure 8. NOR Flash Connection

2.5.2 NAND Flash Memory

The MPC8313E has native support for NAND Flash memory through its NAND Flash control machine (FCM). The MPC8313E RDB implements an 8-bit NAND Flash with 32 Mbyte in size. Figure 9 shows the NAND Flash connection.

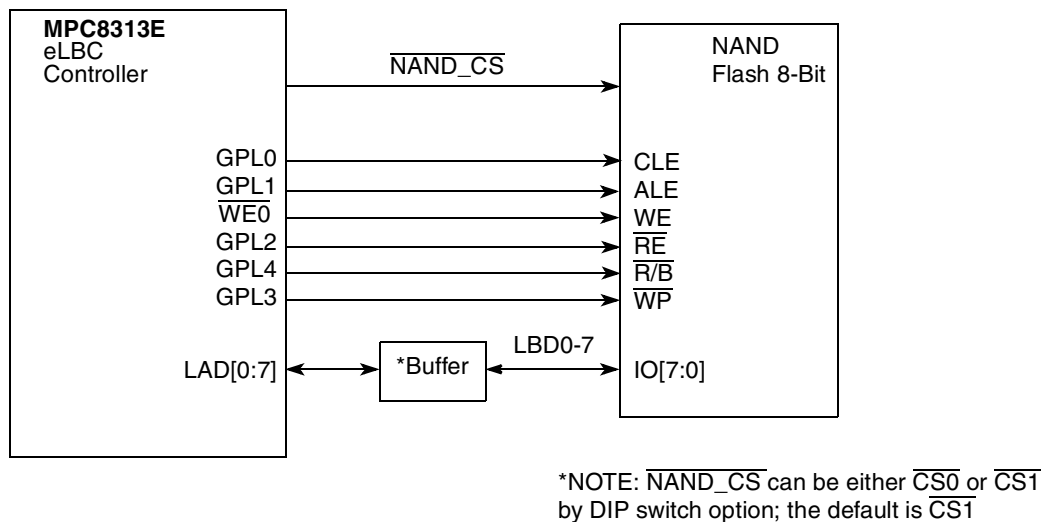

Figure 9. NAND Flash Connection

2.5.3 LED/Status Buffers

The MPC8313E RDB has an 8-bit read/write buffer. The read buffer returns information on M66EN, board revision, boot device (NOR or NAND), and SD card status. The write buffer controls eight LEDs on the board for status or debug indication. Figure 10 shows the hardware connection of the buffers.

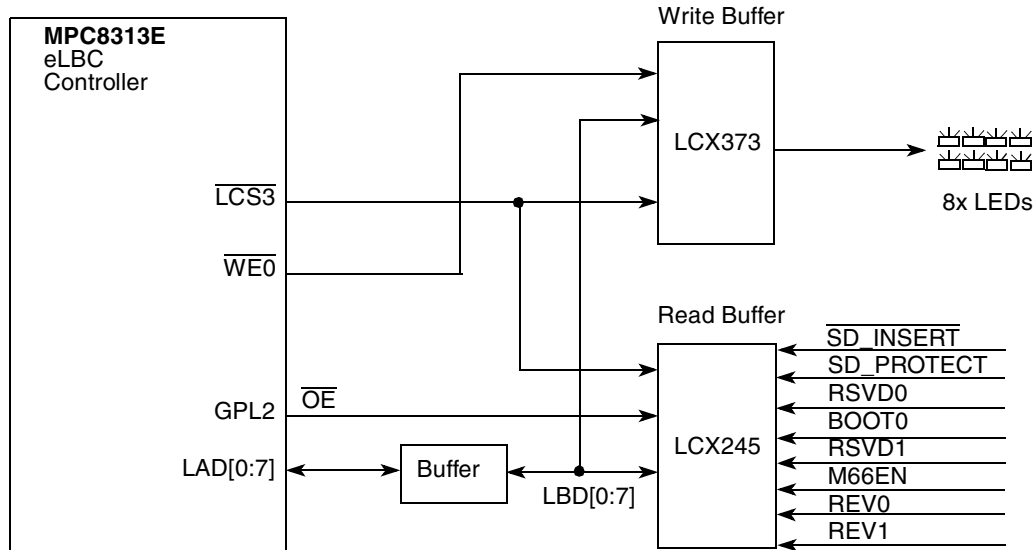

Figure 10. LED/Status Buffers

2.6 I²C Interfaces

The MPC8313E has two I²C interfaces. On the MPC8313E RDB, I²C1 is used as master mode. It is connected to the following three devices as shown in Figure 11.

- Serial EEPROM M24256 at address 0x50.
- Real-time clock DS1339U at address 0x68.
- Thermal sensor LM75 at address 0x48.

It may also be connected to the DAC AD5301 at address 0x0C, whose optional nature is represented in Figure 11 by the dashed line.

The connection of the I²C bus is shown in Figure 11. The M24256 serial EEPROM can be used to store the reset configuration word of the MPC8313E, as well as to store the configuration registers' values and user program if the MPC8313E boot sequencer is enabled. By default, the EEPROM is not used and the hard reset configuration words are loaded from local bus flash memory. For details about how to program

the reset configuration word value in I²C EEPROM and the boot sequencer mode, refer to the MPC8313E reference manual.

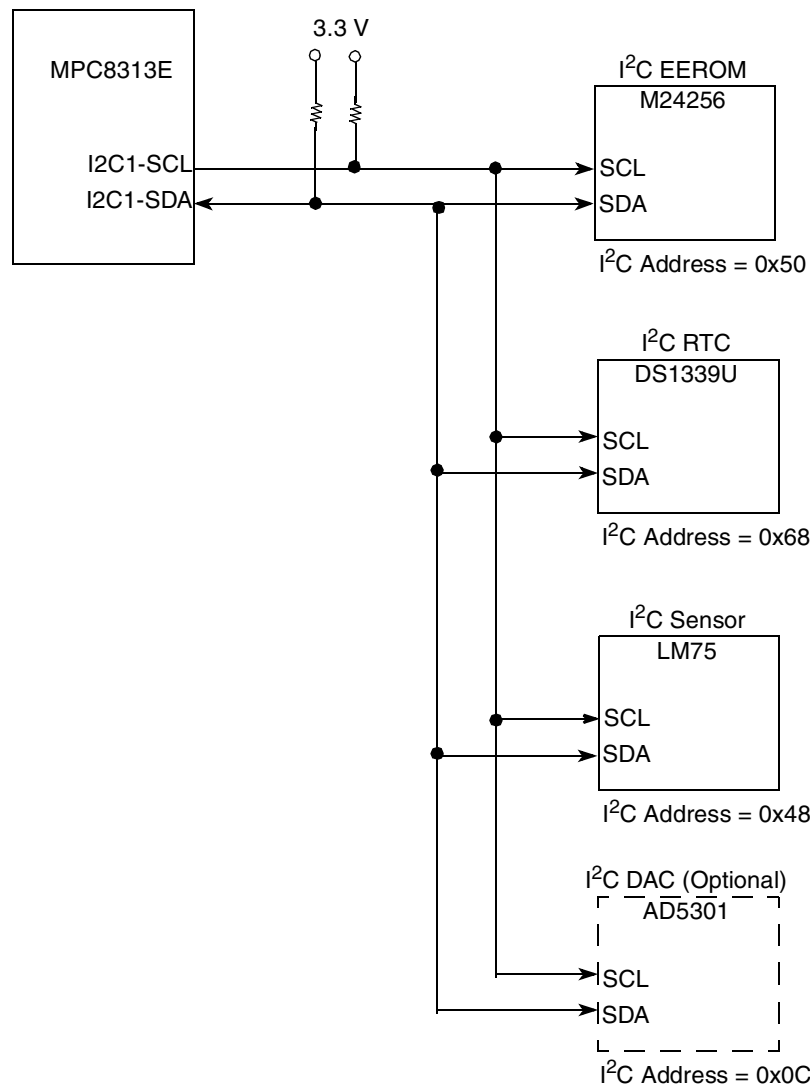

Figure 11. I²C Connection

2.7 SD Memory Card Interface

An SD memory card interface connects directly to the SPI bus of the MPC8313E. SD data mode and SDIO mode are not supported. The SPI mode is the only SD operating mode supported by this connection. Hot insertion and removal is not supported. See Figure 12 for the hardware connection.

For REVB boards, the SD card chip select signal is changed from GPIO31($\overline{\text{SPISEL}}$) to GPIO13(LA8) because when using SPI as master mode, $\overline{\text{SPISEL}}$ cannot be set as GPIO (which is supposed to be used for device select signal). In this case, another GPIO pin should be used. GPIO13 is implemented on this board as an example.

CAUTION

Power down before inserting or removing the SD memory card.

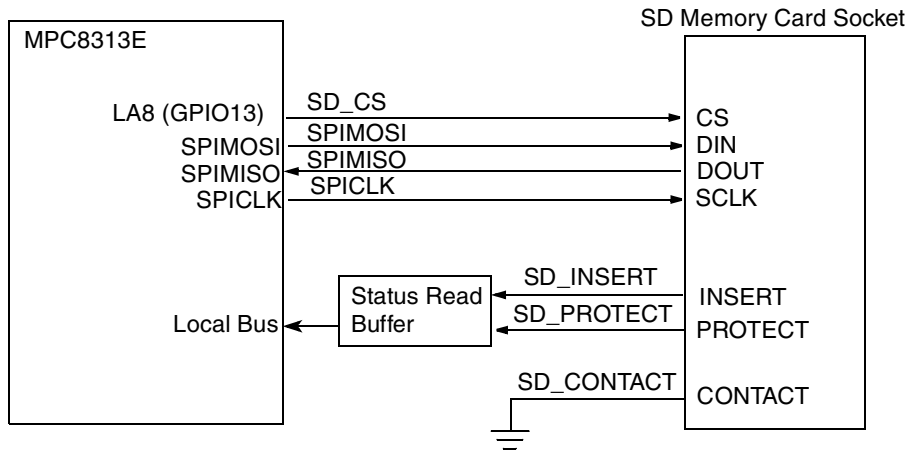
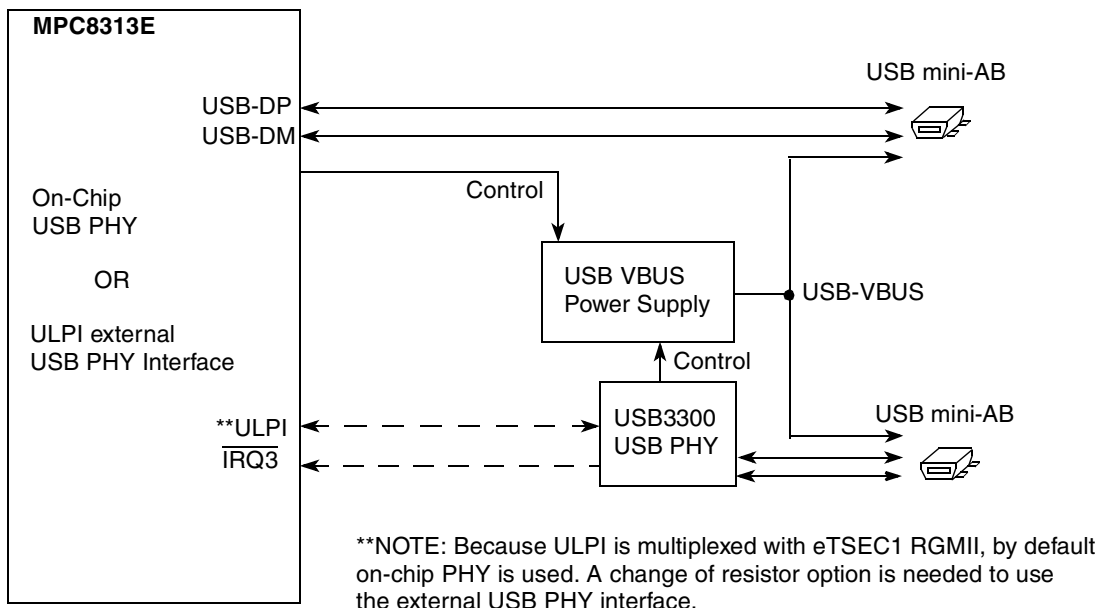

Figure 12. SD Memory Card Connection

2.8 USB Interface

MPC8313E supports a USB 2.0 high speed host/device interface through its on-chip USB PHY or external ULPI USB PHY. The MPC8313E RDB supports both options. By default, the on-chip USB PHY is used. Figure 13 shows the USB connections.



****NOTE:** Because ULPI is multiplexed with eTSEC1 RGMII, by default on-chip PHY is used. A change of resistor option is needed to use the external USB PHY interface.

Figure 13. USB Connections

2.9 eTSEC1 10/100/1000 BaseT Interface

eTSEC1 is set to operate in RGMII mode. It connects to a VSC7385 5-port L2 switch, as shown in Figure 14.

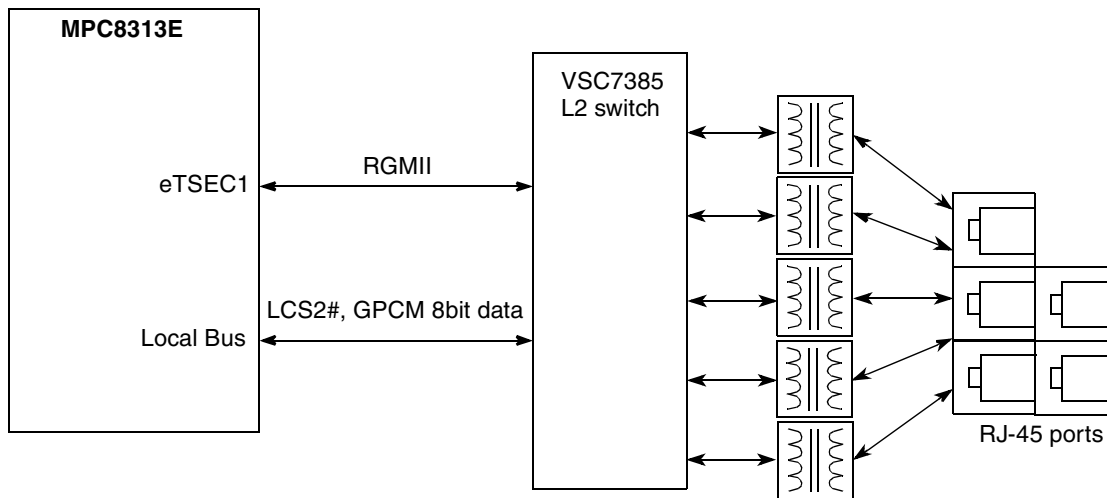

Figure 14. RGMII Interface Connection for L2 Switch

2.10 eTSEC2 10/100/1000 BaseT Interface

eTSEC2 can be set to operate in RGMII mode (default) or SGMII mode. Figure 15 shows the hardware connection for eTSEC.

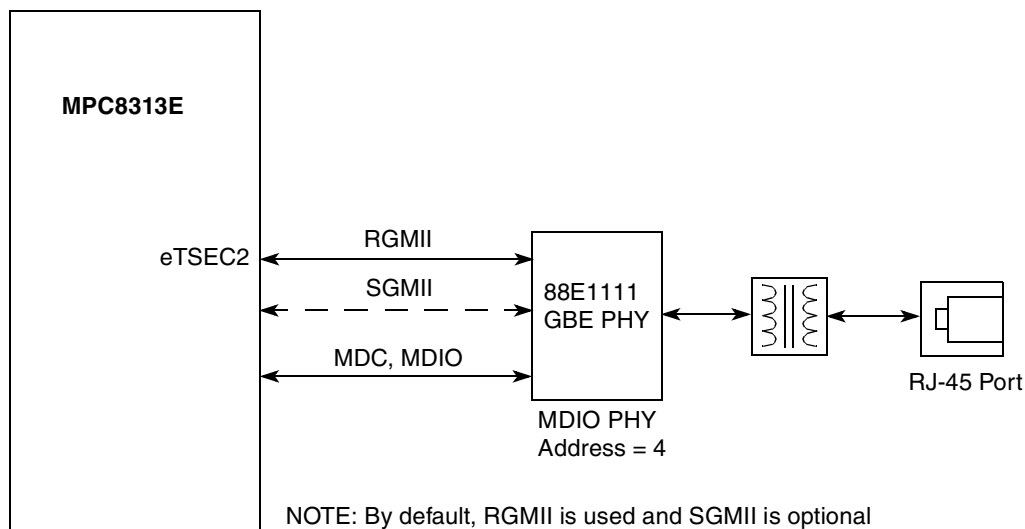

Figure 15. eTSEC2 Connection

2.11 Dual RS-232 Ports

Dual RS-232 ports are supported on the RDB. [Figure 16](#) illustrates the serial port connection using a MAX3232 3.3 V RS-232 driver to interface with a 9-pin D type female connector. This serial connection runs at up to 115.2 Kbps.

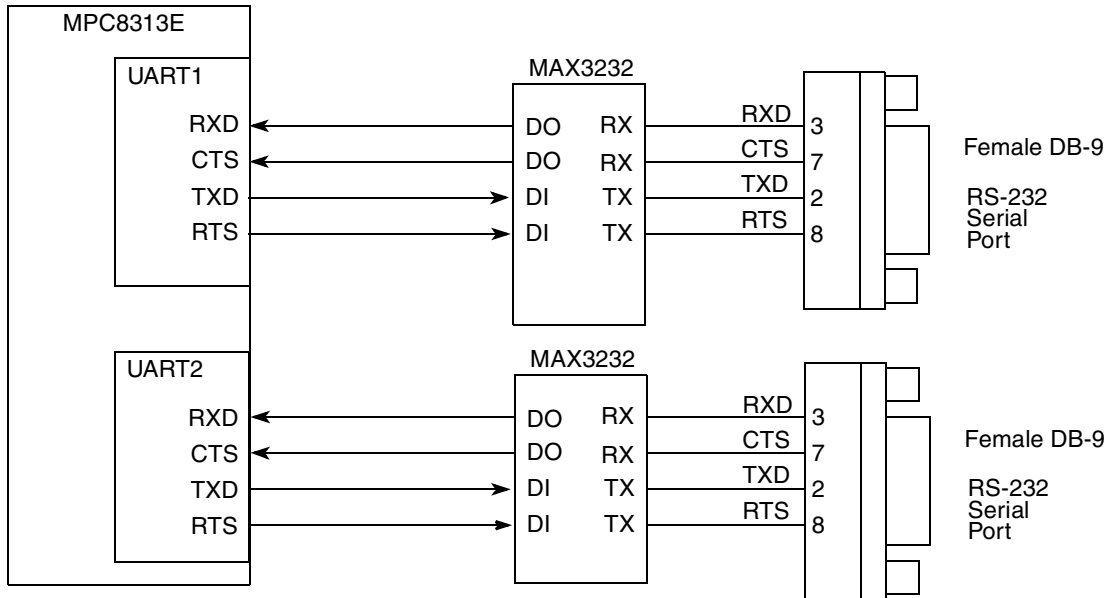

Figure 16. RS-232 Debug Ports Connection

2.12 PCI Bus

The 32-bit PCI interface connects to a 32-bit 3.3 V PCI slot and a miniPCI slot (see [Figure 17](#)).

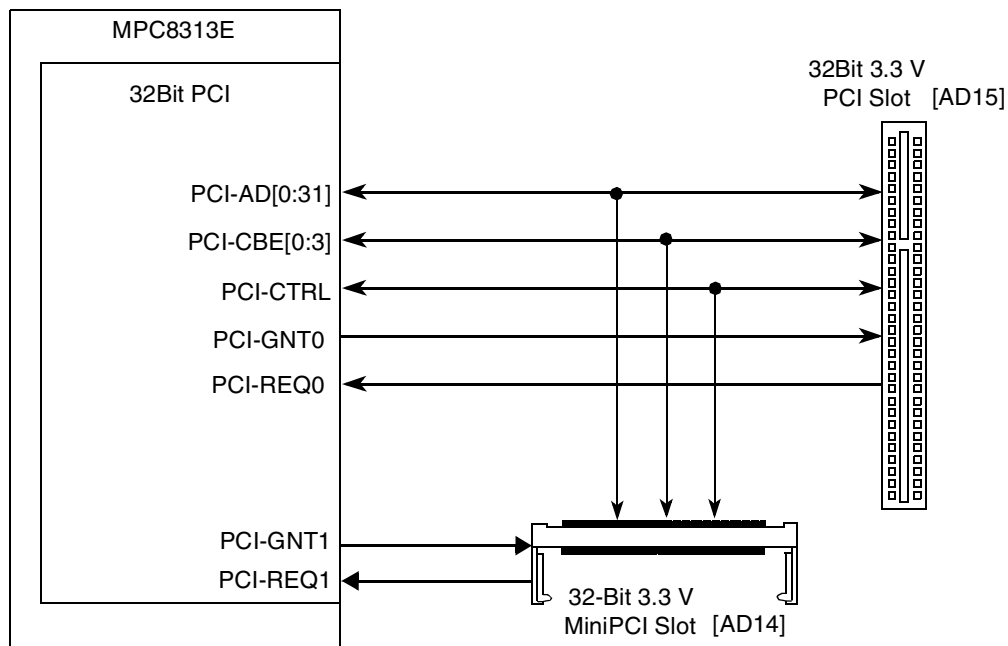

Figure 17. PCI Bus Connection

2.13 COP/JTAG Port

The common on-chip processor (COP) is part of the MPC8313E JTAG module and is implemented as a set of additional instructions and logic. This port can connect to a dedicated emulator for extensive system debugging. Several third-party emulators in the market can connect to the host computer through the Ethernet port, USB port, parallel port, RS-232, and so on. A typical setup using a USB port emulator is shown in [Figure 18](#).

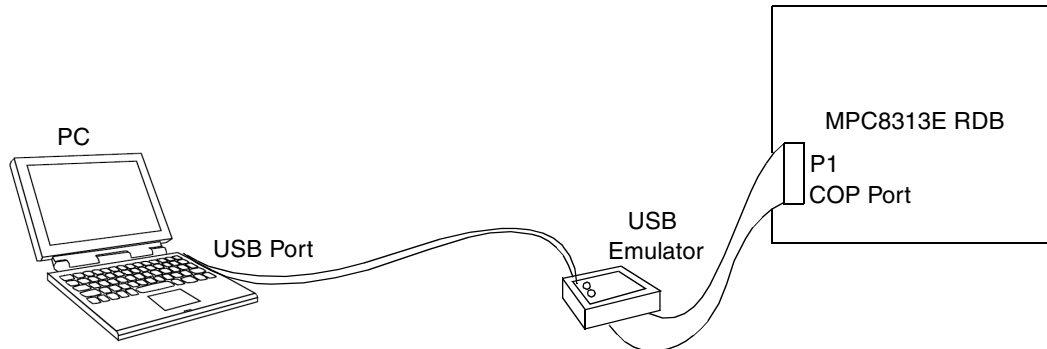

Figure 18. Connecting MPC8313E-RDB to a USB Emulator

The 16-pin generic header connector carries the COP/JTAG signals and the additional signals for system debugging. The pinout of this connector is shown in [Figure 19](#).

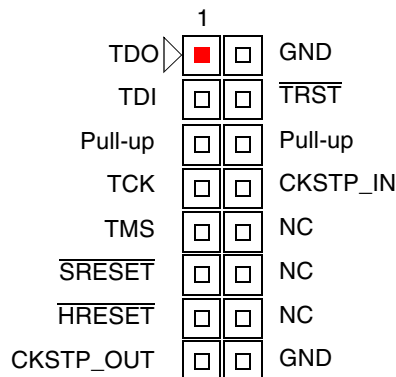

Figure 19. MPC8313E RDB COP Connector

3 Connectors, Jumpers, Switches, and LEDs

[Table 3](#) summarizes the connectors, jumpers, switches, and LEDs on the MPC8313E RDB and provides the number of the section/page on which each is discussed. The rest of this section discusses each of these in the order of its appearance in the table.

Table 3. Connectors, Jumpers, Switches, and LEDs

Reference	Description	Section/Page
Connectors		
P1	14-pin COP/JTAG connector	3.1/Page 21

Table 3. Connectors, Jumpers, Switches, and LEDs (continued)

Reference	Description	Section/Page
P2	3.3 V PCI Slot [IDSEL - AD15]	3.2/Page 21
P3	MiniPCI Slot [IDSEL - AD14]	3.3/Page 22
P4	USB mini-AB Connector (on-chip PHY)	3.4/Page 22
P5	RJ-45 LAN connectors Enet4 (top), Enet5 (bottom). See Figure 23	3.5/Page 23
P6	RJ-45 LAN connectors Enet2 (top), Enet3 (bottom). See Figure 23	
P7	RJ-45 LAN connectors Enet0 (top), Enet1 (bottom). See Figure 23	
P8	USB mini-AB Connector (external ULPI USB PHY)	3.4/Page 22
P9	ATX type power supply connector. The board can be powered by an ATX power supply or the power supply bundled with the mini-ITX case.	—
P10	IEEE 1588 connector (Optional)	3.9/Page 25
P11	Dual UART connector. UART1 (top), UART2 (bottom)	3.6/Page 24
U44	SD memory card socket	3.7/Page 24
BT1	RTC battery holder, CR2032 type. The real-time clock on the RDB requires a battery when the board is powered off. When placing or replacing the battery, take care to ensure that the polarity is correct.	—
J20	Connector for chassis connection (power on, power LED, reset)	—
J21	LCD connector	3.8/Page 24
J22	LCD connector	
J23	LCD backlight connector. A 2-pin header (J23) is provided for LCD backlight power. Pin1 is 5 V and pin 2 is GND.	—
J24	MCU programming connector. J24 is used for MCU programming on the RDB. It is reserved.	—
Jumpers		
J19	Open (Default)—Power ON controlled by switch; Close—Power is always ON	—
Switches		
S1	System reset button. Resets the MPC8313E RDB. ($\overline{\text{PORESET}}$). Press once on the push button reset switch on the RDB to cause a power-on reset ($\overline{\text{PORESET}}$) to the board.	—
S2	Power ON button. Press once to power ON/OFF.	—
S3	DIP switch. Selects the reset configuration source (RST_CFG_SRC) for the MPC8313E.	3.10/Page 26
S4	DIP switch. Board revision indicator and boot device selector.	3.11/Page 26
LEDs		
D6	Enet5 Link 10	—
D7	Enet5 Link 100	—
D8	Enet5 Duplex	—
D9	Enet5 RX	—
D12	USB VBUS	—
D10	On-chip USB PHY CTL0	—

Table 3. Connectors, Jumpers, Switches, and LEDs (continued)

Reference	Description	Section/Page
D11	On-chip USB PHY CTL1	—
D16	12-V Indicator	—
D15	5-V Indicator	—
D14	3.3-V Indicator	—
D17	2.5-V Indicator	—
D13	5-V standby indicator	—
D3	Programmable LED0 (Red)	3.12/Page 27
D5	Programmable LED1 (Yellow)	
D2	Programmable LED2 (Green)	
D1	Programmable LED3 (Green)	
D22	Programmable LED4 (Green)	
D21	Programmable LED5 (Green)	
D20	Programmable LED6 (Green)	
D4	Programmable LED7/LCD_EN (Green)	

3.1 COP Connector (P1)

The COP connector allows the user to connect a COP/JTAG-based debugger to the MPC8313E RDB for debugging. [Table 4](#) lists the pin assignments of the COP connector.

Table 4. COP Connector Pin Assignments

Pin	Signal	Pin	Signal
1	TDO	2	GND
3	TDI	4	$\overline{\text{TRST}}$
5	$\overline{\text{QREQ}}$	6	VDD_SENSE
7	TCK	8	$\overline{\text{CKSTP_IN}}$
9	TMS	10	NC
11	$\overline{\text{SRESET}}$	12	NC
13	$\overline{\text{HRESET}}$	14	NC
15	CKSTP_OUT	16	GND

3.2 PCI Slot (P2)

The MPC8313E RDB has one 32-bit 3.3-V PCI expansion slot (P2) for an expansion card. The slot connects AD15 for its device select signal. Only the 3.3-V PCI card is supported. Turn OFF power during

insertion and removal of the PCI card. As Figure 20 shows, 3.3-V PCI cards can be identified by the key position on the PCI card.

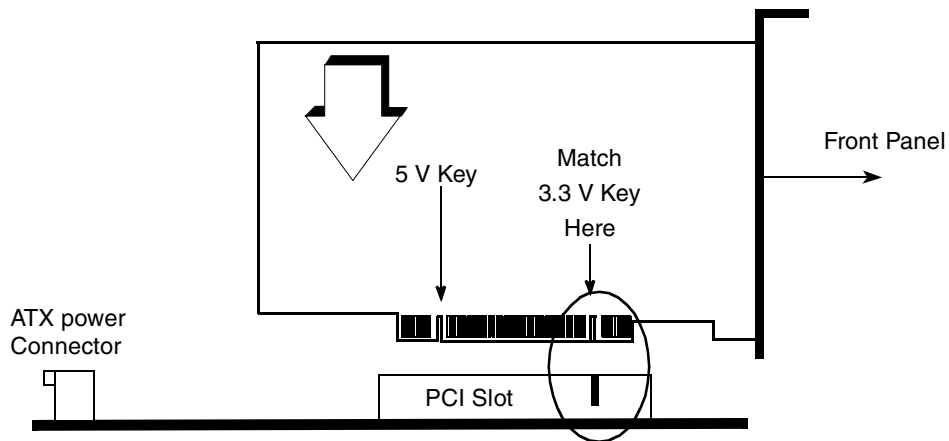

Figure 20. 3.3 V Key on a Typical 3.3 V PCI Card

3.3 MiniPCI Connector (P3)

There is a MiniPCI connector (P3) on the RDB. The slot connects to AD14 for its device select signal. Figure 21 shows how to install a MiniPCI card.

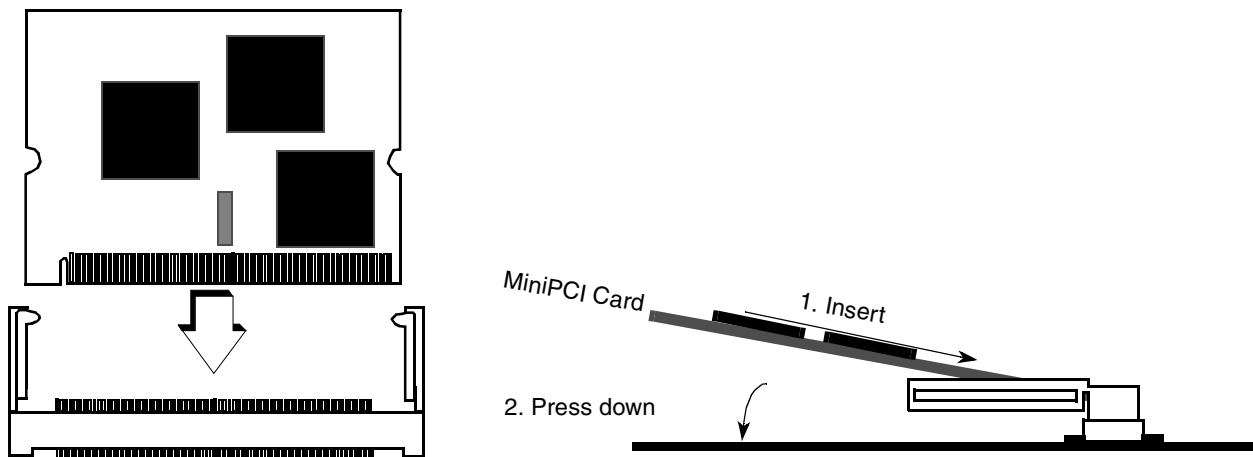

Figure 21. Installation of MiniPCI Card

3.4 USB Connectors (P4, P8)

There are two USB connectors on the MPC8313E RDB. One connects to the on-chip PHY of the MPC8313E, and the other connects to the external ULPI USB PHY. Either can be enabled at a time. The

selection between the two requires modification of micro-jumpers/resistor options as discussed later. By default, the on-chip PHY USB is used. Figure 22 shows the USB connectors in front panel.

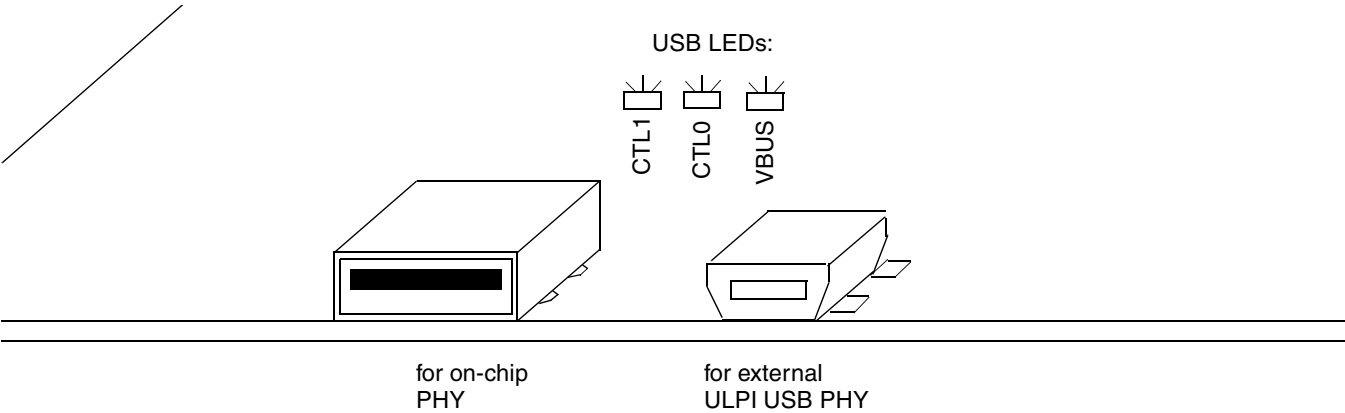

Figure 22. USB Connectors

3.5 Ethernet Connectors (P5, P6, P7)

The MPC8313E RDB has six Ethernet ports (RJ-45). The first five ports (G0–G4) are supported by eTSEC1 (L2 switch), and the last port (G5) is supported by eTSEC2 (GBE PHY). Figure 23 shows the G0–G5 mapping viewing from the front panel.

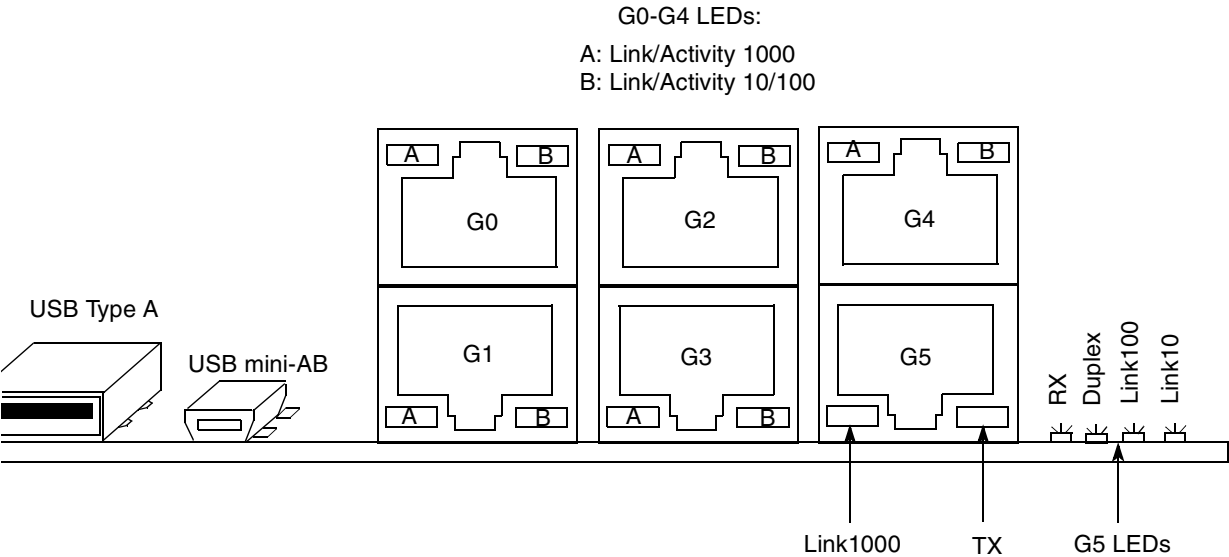

Figure 23. Ethernet Connectors

3.6 RS-232 UART Connector (P11)

Serial interfaces are available at connector P11. It is a double deck RS-232 female connector. The upper port is UART1 and the lower port is UART2. By default, UART1 is used. Figure 24 shows the RS-232 UART connector front view.

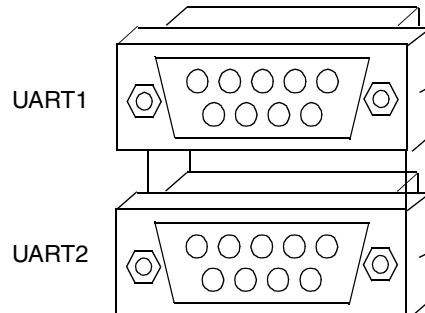

Figure 24. RS-232 UART Connectors

3.7 SD Memory Card Socket (U44)

An SD card socket (U44) for SD memory card installation is located next to the UART connector of the board. Figure 25 shows how to install a compact flash card.

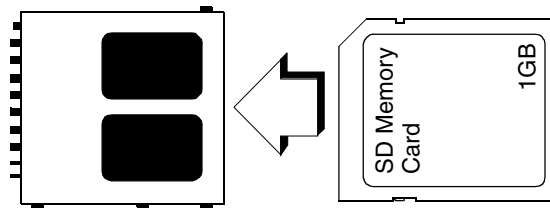

Figure 25. Installation of SD Card

3.8 LCD Connectors (J21, J22)

Two headers (J21, J22) are provided for LCD connections. They use the MPC8313E GPIO interface. Both headers carry the same set of GPIO signal pins, but they are different physically. J21 is single row of 1×14 , and J22 is double row of 2×7 . Table 5 shows the mapping.

Table 5. LCD Connector Pin Assignment

Pin Number	Description
1	GND
2	5 V
3	5 V to -5 V variable
4	GPIO2
5	GPIO3
6	GPIO1

Table 5. LCD Connector Pin Assignment (continued)

Pin Number	Description
7	Pull-down
8	Pull-down
9	Pull-down
10	Pull-down
11	GPIO7
12	GPIO6
13	GPIO5
14	GPIO4

3.9 IEEE 1588 Connector (Optional)

A header (P10) is provided for IEEE 1588 signals connection. It is double row of 2×8 header connector. The pinout of this connector is shown in [Figure 26](#).

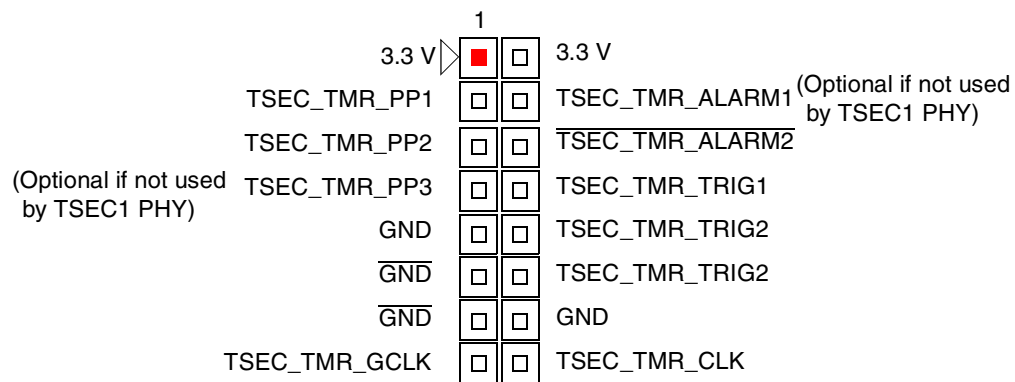
**Figure 26. IEEE 1588 Connector (Optional)**

3.10 DIP Switch S3

DIP switch S3 selects the reset configuration source (RST_CFG_SRC) for the MPC8313E. [Figure 27](#) shows the factory default configuration of S3.

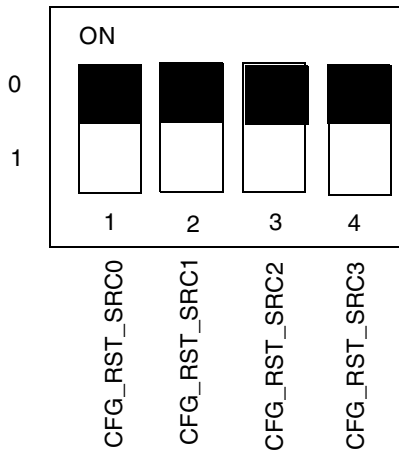

Figure 27. DIP Switch S3

Check the MPC8313E reference manual for the meaning of the CFG_RST_SRC combination. By default, the DIP switch is set to all ON, meaning $\text{CFG_RST_SRC}[0..3] = 0000$. In this case, the hardware reset configuration is loaded from local bus NOR flash memory.

3.11 DIP Switch S4

DIP switch S4 on the RDB is shown in [Figure 28](#), with the factory default configuration.

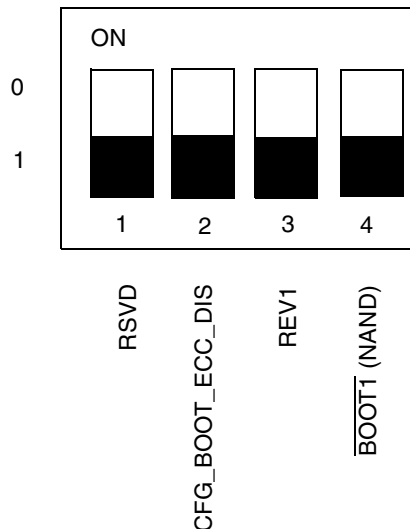

Figure 28. DIP Switch S4

RSVD is reserved. When software options are implemented, their values can be read from a buffer on the board. CFG_BOOT_ECC_DIS switch is OFF by default to disable booting with ECC by driving HIGH to

the signal LB_POR_CFG_BOOT_ECC_DIS (TSEC1_MDC) during power on reset (REVB and REVC only. REV_{Ax} is a reserved switch (RSVD0)). REV1 represents bit 1 of the revision number. Together with REV0 (implemented by resistor option; the default is 0), REV[0..1] shows the revision number, which is 01 by default. The values can be read from a buffer on the RDB. $\overline{\text{BOOT1}}$ selects the boot device on the RDB. By default, $\overline{\text{BOOT1}}$ is set, so chip-select 0 ($\overline{\text{CS0}}$) is connected to the NOR Flash. $\overline{\text{CS1}}$ is connected to the NAND Flash memory. If $\overline{\text{BOOT1}}$ is cleared, $\overline{\text{CS0}}$ is connected to NAND Flash memory, and $\overline{\text{CS1}}$ is connected to NOR Flash memory.

3.12 RDB Programmable LEDs

Eight programmable LEDs give status indication and debug information. Figure 29 shows the diagram.

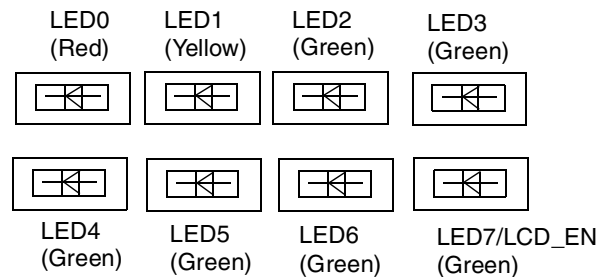

Figure 29. Programmable LEDs

An 8-bit write register on the RDB turns the LEDs on and off. The LEDs are arranged so that the most significant bit represents LED0 and least significant bit represents LED7; that is, LED[0..7]. A write of 0x00 turns on all LEDs, and 0xFF turns off all LEDs.

4 Micro-Jumper/Resistor Options for eTSEC1

The eTSEC1 RGMII, ULPI USB, and IEEE 1588 signals are multiplexed on the MPC8313E. The MPC8313E RDB supports switching among the three interfaces using micro-jumpers (REVA boards) or resistor options (REVA1 or later boards).

NOTE

For IEEE 1588 support, use the same setting as for the eTSEC1 RGMII. In this case, a 50 MHz clock would be provided for the IEEE 1588 TMR_CLK pin.

4.1 For REVA Boards

Figure 30 shows the micro-jumper locations.

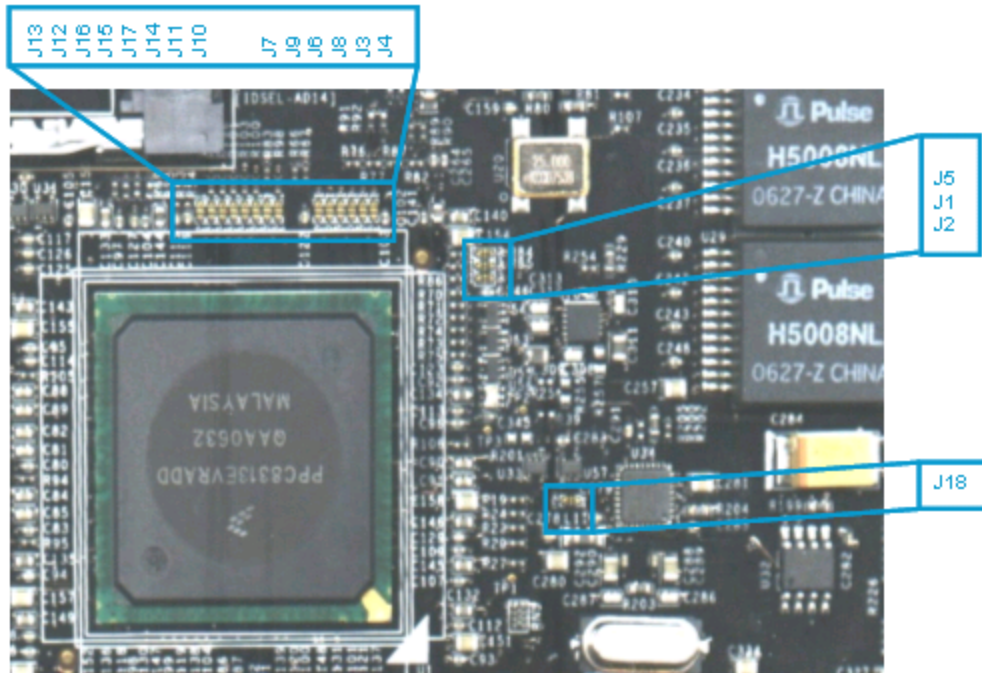

Figure 30. REVA Micro-jumper Locations

By default the REVA boards are shipped with the following settings:

Setup 1:

- eTSEC1, RGMII
- eTSEC2, RGMII

The corresponding micro-jumper settings are shown in Table 6.

Table 6. Default Micro-jumper Settings for REVA

Jumper	Setting	Jumper	Setting	Jumper	Setting	Jumper	Setting
J13	1-2	J7	1-2	J5	open	J18	2-3
J12	1-2	J9	1-2	J1	open		
J16	1-2	J6	1-2	J2	open		
J15	1-2	J8	1-2				
J17	1-2	J3	1-2				
J14	1-2	J4	1-2				
J11	open						
J10	1-2						

There are alternative settings for REVA boards:

Setup 2:

- eTSEC1, USB DR with external ULPI USB PHY (USB3300)
- eTSEC2, SGMII (remove R87, C275; connect 125 MHz clock from R181 to SGMII SCLK)

The corresponding micro-jumper settings are shown in [Table 7](#).

Table 7. Alternative Micro-jumper Settings for REVA (Setup 2)

Jumper	Setting	Jumper	Setting	Jumper	Setting	Jumper	Setting
J13	open	J7	2-3	J5	2-3	J18	1-2
J12	open	J9	2-3	J1	2-3		
J16	open	J6	2-3	J2	2-3		
J15	open	J8	2-3				
J17	open	J3	2-3				
J14	2-3	J4	2-3				
J11	2-3						
J10	2-3						

Setup 3:

- eTSEC1, USB DR with external ULPI USB PHY (USB3300)
- eTSEC2, RGMII

The corresponding micro-jumper settings are shown in [Table 8](#).

Table 8. Alternative Micro-jumper Settings for REVA (Setup 3)

Jumper	Setting	Jumper	Setting	Jumper	Setting	Jumper	Setting
J13	open	J7	2-3	J5	2-3	J18	1-2
J12	open	J9	2-3	J1	2-3		
J16	open	J6	2-3	J2	2-3		
J15	open	J8	2-3				
J17	open	J3	2-3				
J14	2-3	J4	2-3				
J11	2-3						
J10	2-3						

Setup 4

- eTSEC1, RGMII
- eTSEC2, SGMII (remove R87, C275; connect 125 MHz clock from R181 to SGMII SCLK)

The corresponding micro-jumper settings are shown in [Table 9](#).

Table 9. Alternative Micro-jumper Settings for REVA (Setup 4)

Jumper	Setting	Jumper	Setting	Jumper	Setting	Jumper	Setting
J13	1-2	J7	1-2	J5	open	J18	2-3
J12	1-2	J9	1-2	J1	open		
J16	1-2	J6	1-2	J2	open		
J15	1-2	J8	1-2				
J17	1-2	J3	1-2				
J14	1-2	J4	1-2				
J11	open						
J10	1-2						

Because the eTSEC1 Ethernet switch PHY on the RDB supports only RGMII, the eTSEC1 SGMII is not supported. The micro-jumper settings listed only matter for the eTSEC1 pin connections. They have nothing to do with switching between eTSEC2 RGMII and SGMII. The settings of eTSEC2 SGMII are provided as a reference.

4.2 REVA1 to REVA4 Boards

For REVA1 or later boards, the micro-jumpers are replaced by resistor options for easier modification. Figure 31 shows the resistor locations. Table 10 shows the default configuration.

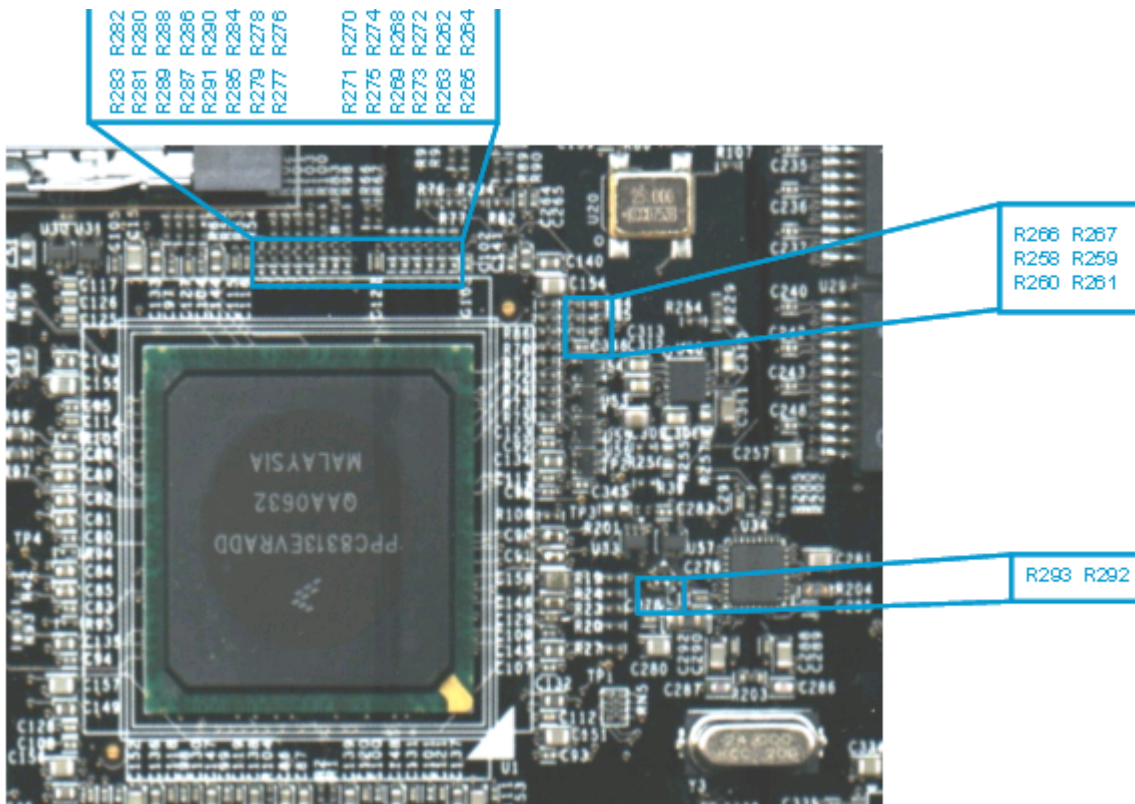

Figure 31. Locations of Resistor Options on REVA1 or Later Boards

Setup 1:

- eTSEC1, RGMII
- eTSEC2, RGMII

Table 10. Default Resistor Options for REVA1 to REVA4

Resistor	Setting	Resistor	Setting	Resistor	Setting	Resistor	Setting
R258	short	R267	open	R276	short	R285	open
R259	open	R268	short	R277	open	R286	short
R260	short	R269	open	R278	short	R287	open
R261	open	R270	short	R279	open	R288	short
R262	short	R271	open	R280	short	R289	open
R263	open	R272	short	R281	open	R290	short
R264	short	R273	open	R282	short	R291	open

Table 10. Default Resistor Options for REVA1 to REVA4 (continued)

Resistor	Setting	Resistor	Setting	Resistor	Setting	Resistor	Setting
R265	open	R274	short	R283	open	R293	short
R266	short	R275	open	R284	short	R292	open

Figure 32 shows the graphical representation for Setup 1.

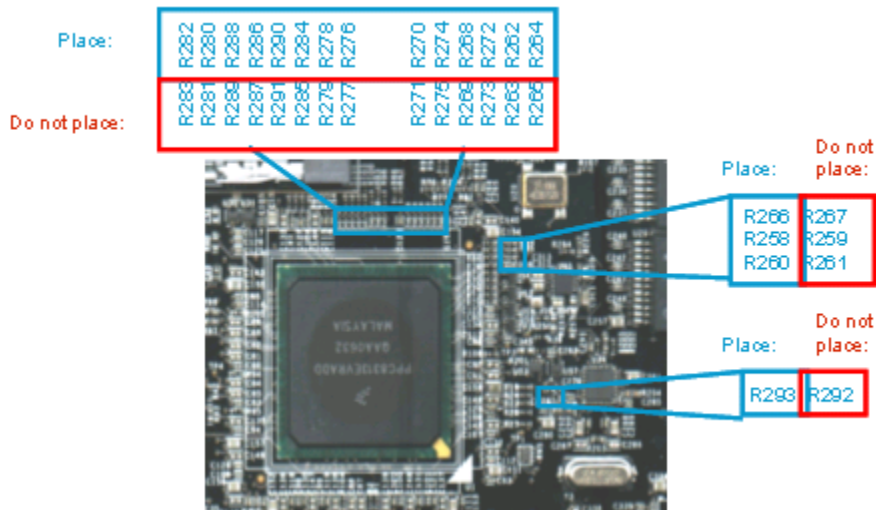

Figure 32. Default Resistor Options for REVA1

Table 11 shows the alternative configuration.

Setup 2:

- eTSEC1, USB DR with external ULPI USB PHY (USB3300)
- eTSEC2, SGMII

Table 11. Setup 2 Resistor Options for REVA1

Resistor	Setting	Resistor	Setting	Resistor	Setting	Resistor	Setting
R258	open	R267	short	R276	open	R285	short
R259	short	R268	open	R277	short	R286	open
R260	open	R269	short	R278	open	R287	short
R261	short	R270	open	R279	short	R288	open
R262	open	R271	short	R280	open	R289	short
R263	short	R272	open	R281	short	R290	open
R264	open	R273	short	R282	open	R291	short
R265	short	R274	open	R283	short	R293	open
R266	open	R275	short	R284	open	R292	short

Figure 33 shows the graphical representation for Setup 2.

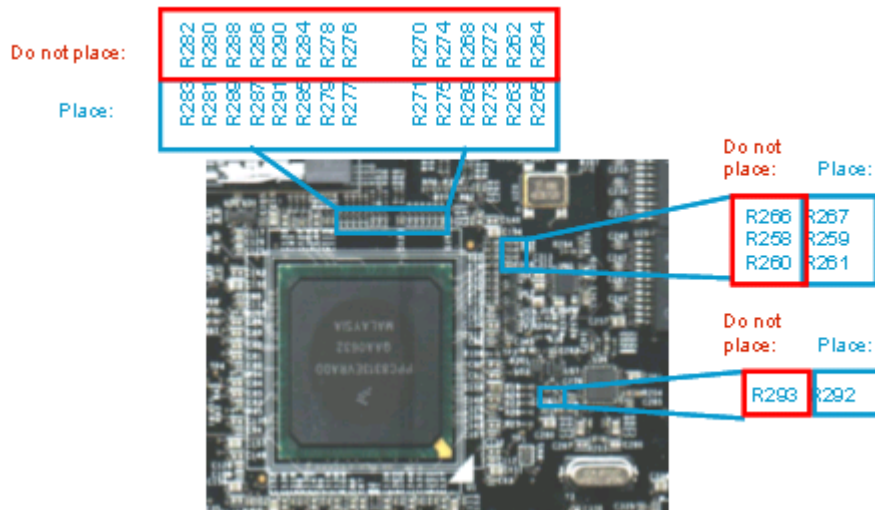

Figure 33. Setup 2 Resistor Options for REVA1

Table 12 shows the alternative configuration.

Setup 3:

- eTSEC1, USB DR with external ULPI USB PHY (USB3300)
- eTSEC2, RGMII

Table 12. Setup 3 Resistor Options for REVA1

Resistor	Setting	Resistor	Setting	Resistor	Setting	Resistor	Setting
R258	open	R267	short	R276	open	R285	short
R259	short	R268	open	R277	short	R286	open
R260	open	R269	short	R278	open	R287	short
R261	short	R270	open	R279	short	R288	open
R262	open	R271	short	R280	open	R289	short
R263	short	R272	open	R281	short	R290	open
R264	open	R273	short	R282	open	R291	short
R265	short	R274	open	R283	short	R293	open
R266	open	R275	short	R284	open	R292	short

Figure 34 shows the graphical representation for Setup 3.

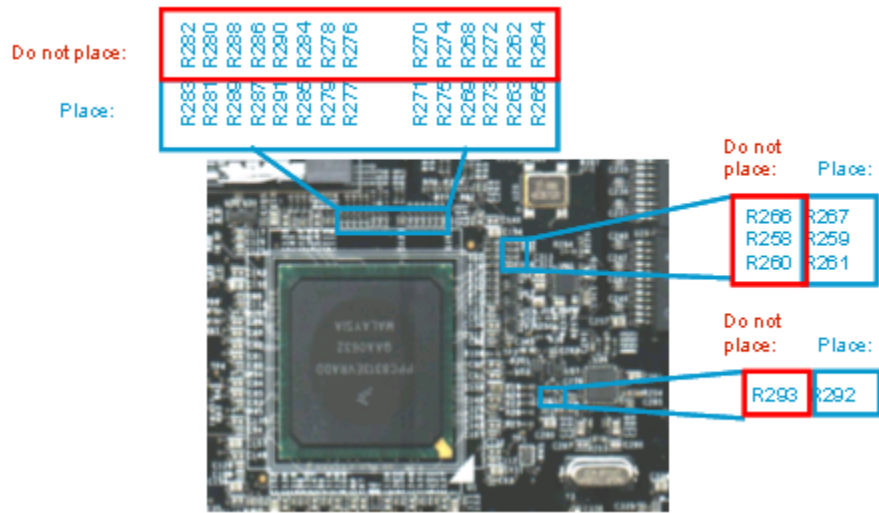

Figure 34. Setup 3 Resistor Options for REVA1

Table 13 shows the alternative configuration.

Setup 4:

- eTSEC1, RGMII
- eTSEC2, SGMII

Table 13. Setup 4 Resistor Options for REVA1

Resistor	Setting	Resistor	Setting	Resistor	Setting	Resistor	Setting
R258	short	R267	open	R276	short	R285	open
R259	open	R268	short	R277	open	R286	short
R260	short	R269	open	R278	short	R287	open
R261	open	R270	short	R279	open	R288	short
R262	short	R271	open	R280	short	R289	open
R263	open	R272	short	R281	open	R290	short
R264	short	R273	open	R282	short	R291	open
R265	open	R274	short	R283	open	R293	short
R266	short	R275	open	R284	short	R292	open

Figure 35 shows the graphical representation for Setup 4.

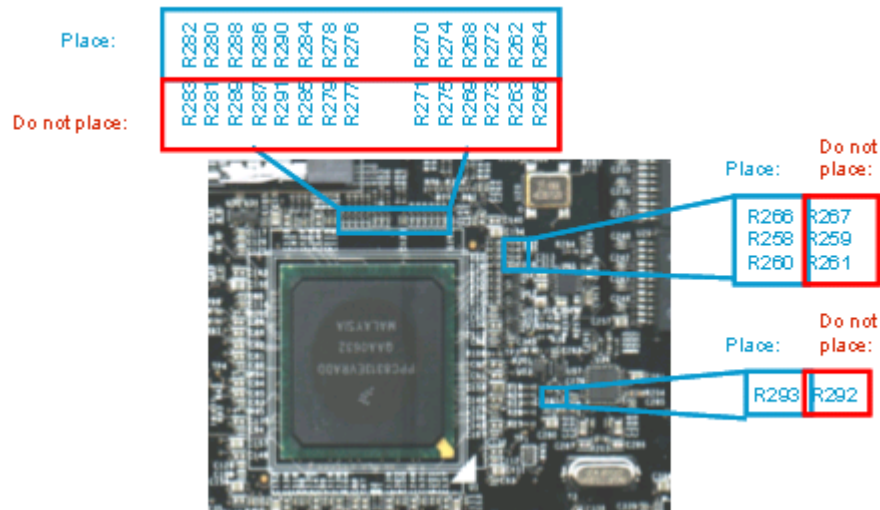

Figure 35. Setup 4 Resistor Options for REVA1

Because the eTSEC1 Ethernet switch PHY on the RDB supports only RGMII, the eTSEC1 SGMII is not supported on the RDB. The resistor options listed only matter for the eTSEC1 pin connections. They have nothing to do with switching between eTSEC2 RGMII and SGMII. They are listed for reference. The switch between eTSEC2 RGMII and SGMII does not require hardware modification on the RDB.

4.3 REVB Boards

For REVB boards, three more resistor options (R311–R313) are added to route three IEEE 1588 signals to the IEEE 1588 connector.

All other resistor options are the same as on the REVA1 to REVA4 boards.

Table 14 shows how to populate the resistors if these three optional signals are used.

Table 14. Resistor Options for REVB Using Three Optional IEEE 1588 Signals

Signal	Resistor	Setting	Resistor	Setting	Resistor	Setting
TSEC_TMR_TRIG2/TSEC1_RX_ER/ULPI1_DIR	R311	short	R266	open	R267	open
TSEC_TMR_ALARM1/TSEC1_RX_ER/ULPI1_CLK	R312	short	R280	open	R281	open
TSEC_TMR_PP3/TSEC1_RX_ER/ULPI1_STP	R313	short	R284	open	R285	open

4.4 REVC Boards

For REVC boards, 22 more resistor options (R311–R313) are added to route eTSEC2 RGMII signals either to L2 Switch or Marvell 88E1111 PHY. All other resistor options are the same as on the REVB boards.

Table 15 shows how to populate the resistors if routing eTSEC2 RGMII signals to L2 Switch.

Setup 1:

eTSEC1, RGMII signals to L2 Switch

Table 15. Setup 1 Resistor Options for REVC

Resistor	Setting	Resistor	Setting	Resistor	Setting	Resistor	Setting	Resistor	Setting
R118	short	R346	open	R336	short	R370	short	R360	short
R342	open	R123	short	R337	open	R352	short	R361	open
R119	short	R347	open	R338	short	R353	open	R362	short
R343	open	R330	short	R339	open	R354	short	R363	open
R120	short	R331	open	R340	short	R355	open	R365	short
R344	open	R332	short	R341	open	R356	short	R364	open
R121	short	R333	open	R345	open	R357	open	R366	short
R345	open	R334	short	R350	short	R358	short	R367	open
R122	short	R335	open	R346	open	R359	open	-	-

Figure 36 shows the graphical representation for Setup 1.

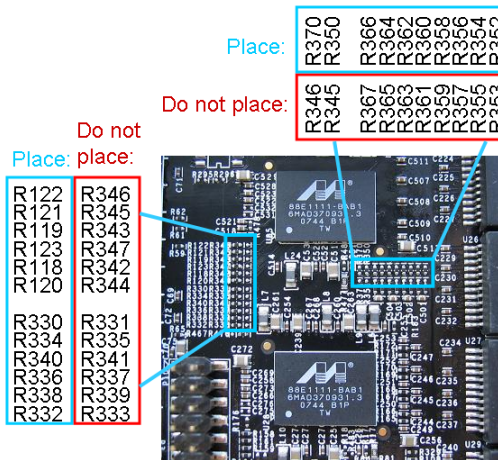

Figure 36. Setup 2 Resistor Options for REVC

Table 16 shows the alternative configuration.

Setup 2:

- eTSEC1, RGMII signals to PHY

Table 16. Setup 2 Resistor Options for REVC

Resistor	Setting	Resistor	Setting	Resistor	Setting	Resistor	Setting	Resistor	Setting
R118	open	R346	open	R336	short	R370	short	R360	short
R342	short	R123	short	R337	open	R352	short	R361	open
R119	open	R347	short	R338	open	R353	short	R362	open
R343	short	R330	open	R339	short	R354	open	R363	short
R120	open	R331	short	R340	open	R355	short	R365	open
R344	short	R332	open	R341	short	R356	open	R364	short
R121	open	R333	short	R345	short	R357	short	R366	open
R345	short	R334	open	R350	open	R358	open	R367	short
R122	open	R335	short	R346	short	R359	short	-	-

Figure 37 shows the graphical representation for Setup 2.

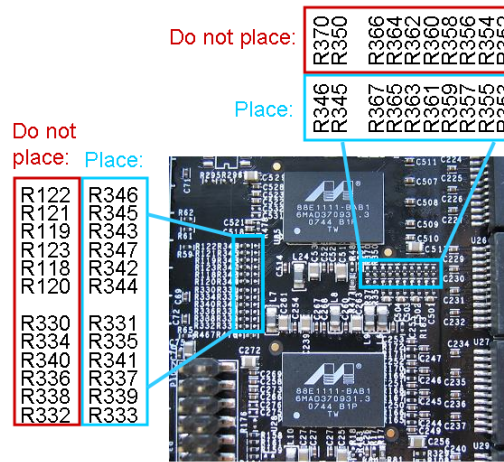

Figure 37. Setup 2 Resistor Options for REVC

Table 17 shows the alternative configuration.

Setup 3:

- eTSEC1, SGMII signals to PHY

Table 17. Setup 3 Resistor Options for REVC

Resistor	Setting	Resistor	Setting	Resistor	Setting	Resistor	Setting	Resistor	Setting
R118	open	R346	open	R336	short	R370	short	R360	short
R342	short	R123	short	R337	open	R352	short	R361	open

Table 17. Setup 3 Resistor Options for REVC (continued)

Resistor	Setting	Resistor	Setting	Resistor	Setting	Resistor	Setting	Resistor	Setting
R119	open	R347	short	R338	open	R353	short	R362	open
R343	short	R330	open	R339	short	R354	open	R363	short
R120	open	R331	short	R340	open	R355	short	R365	open
R344	short	R332	open	R341	short	R356	open	R364	short
R121	open	R333	short	R345	short	R357	short	R366	open
R345	short	R334	open	R350	open	R358	open	R367	short
R122	open	R335	short	R346	short	R359	short	-	-

Figure 38 shows the graphical representation for Setup 3.

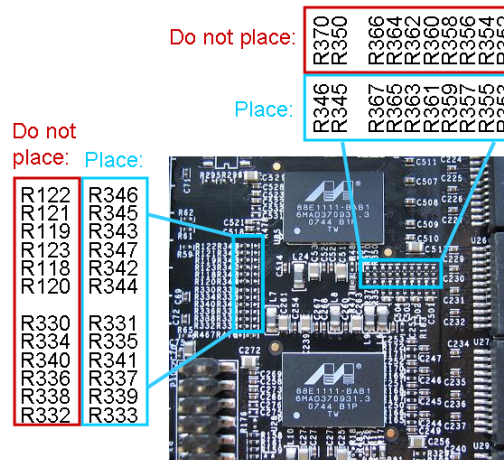

Figure 38. Setup 2 Resistor Options for REVC

5 MPC8313E RDB Board Configuration

This section describes the operational frequency and configuration options of the MPC8313E RDB.

5.1 PCI Operating Frequency

An M66EN input pin determines the frequency of the PCI interface. On the MPC8313E RDB, the M66EN signal level is determined by the PCI agent card connected to the miniPCI or PCI slot. If a 33 MHz-only card is inserted, the M66EN signal is driven to 0 by the PCI agent card according to the PCI specification. However, it is pulled to 1 if it can perform at 66 MHz. By default, the MPC8313E RDB runs its PCI interfaces at 66 MHz unless a 33-MHz PCI card is inserted.

5.2 Reset Configuration Word

The reset configuration word (RCW) controls the clock ratios and other basic device functions such as PCI host or agent mode, boot location, and endian mode. The reset configuration word is divided into reset

configuration word lower (RCWL) and reset configuration word higher (RCWH) and is loaded from the local bus during the power-on or hard reset flow. The default RCW low bit setting is 0x6204_0000. The default RCW high bit setting is 0xA060_7800. The RCW is located at the lowest 64 bytes of the boot flash memory, which is 0xFE00_0000 if the default memory map is used.

Table 18 shows the default RCW in the flash memory.

Table 18. Default RCW in Flash Memory

Address				
FE000000:	62626262	62626262	04040404	04040404
FE000010:	00000000	00000000	00000000	00000000
FE000020:	A0A0A0A0	A0A0A0A0	60606060	60606060
FE000030:	78787878	78787878	00000000	00000000

The RCW definitions are shown in Figure 39 and Figure 40.

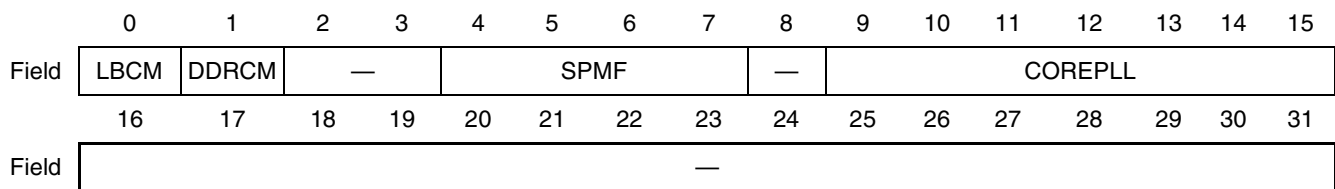

Figure 39. Reset Configuration Word Low (RCWL) Bit Settings

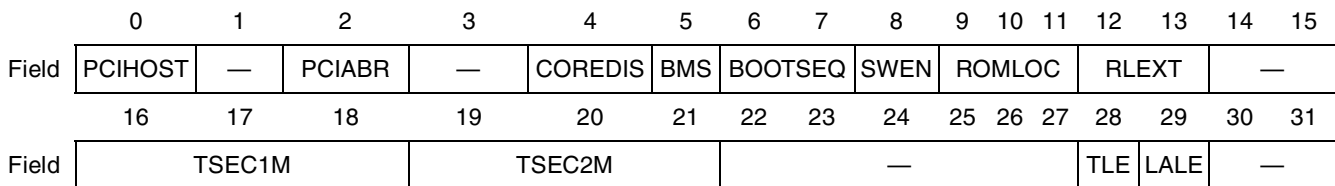

Figure 40. Reset Configuration Word High (RCWH) Bit Settings

Table 19. RCWL Bit Descriptions

Bits	Name	Meaning	Description	
0	LBCM	Local bus clock mode	Local Bus Controller Clock: CSB_CLK	
			0: Default	Ratio 1:1
			1	Ratio 2:1
1	DDRCM	DDR SDRAM clock mode	DDR Controller Clock: CSB_CLK	
			0	Ratio 1:1
			1: Default	Ratio 2:1
2-3	—	Reserved	Must be set to 10	

Table 19. RCWL Bit Descriptions (continued)

Bits	Name	Meaning	Description	
4–7	SPMF[0–3]	System PLL multiplication factor	0000	Reserved
			0001	Reserved
			0010 (Default)	2:1
			0011	3:1
			0100	4:1
			0101	5:1
4–7	SPMF[0–3]	System PLL multiplication factor	0110	6:1
			0111-1111	Reserved
8	—	Reserved	Must be cleared.	
9–15	COREPLL [0–6]	Value	coreclk: csb_clk	VCO divider
		nn 0000 0	PLL bypassed	PLL bypassed
		00 0001 0	1:1	2
		01 0001 0	1:1	4
		10 0001 0	1:1	8
		00 0001 1	1.5:1	2
		01 0001 1	1.5:1	4
		10 0001 1	1.5:1	8
	00 0010 0 (Default)	2:1	2	
9–15	COREPLL [0–6]	01 0010 0	2:1	4
		10 0010 0	2:1	8
		00 0010 1	2.5:1	2
		01 0010 1	2.5:1	4
		10 0010 1	2.5:1	8
		00 0011 0	3:1	2
		01 0011 0	3:1	4
		10 0011 0	3:1	8
16–31	—	Reserved.	Must be cleared.	

Table 20. Reset Configuration Word High (RCWH) Bit Descriptions

Bits	Name	Meaning	Description	
0	PCIHOST	PCI host mode	0	PCI agent
			1: Default	PCI host
1	Reserved	—	Must be cleared	
2	PCIARB	PCI1 arbiter	0	PCI arbiter disabled
			1: Default	PCI arbiter enabled
3	Reserved	—	Must be cleared	
4	COREDIS	Core disable mode	0: Default	e300 enabled
			1	e300 disabled
5	BMS	Boot memory space	0: Default	0x0000_0000–0x007F_FFFF
			1	0xFF80_0000–0xFFFF_FFFF
6–7	BOOTSEQ	Boot sequencer configuration	00: Default	Boot sequencer is disabled
			01	Boot sequencer load configuration from I ² C
			10	Boot sequencer load configuration from EEPROM
			11	Reserved
8	SWEN	Software watchdog enable	0: Default	Disabled
			1	Enabled
9–11	ROMLOC	Boot ROM interface location	000	DDR2 SDRAM
			001	PCI
			010,011, 100	Reserved
			101	Local bus GPCM, 8 bits
			110: Default	Local bus GPCM, 16 bits
			111	Reserved
12–13	RLEXT	Boot ROM location extension	00: Default	Legacy mode
			01	NAND Flash mode
			10,11	Reserved
14-15	Reserved	—	Must be cleared	
16-18	TSEC1M	TSEC1 Mode	000	MII mode
			001	RMII mode
			011:Default	RGMI mode
			101	RTBI mode
			110	SGMI mode
			010,100,111	Reserved

Table 20. Reset Configuration Word High (RCWH) Bit Descriptions (continued)

Bits	Name	Meaning	Description	
19-21	TSEC2M	TSEC2 Mode	000	MII mode
			001	RMII mode
			011:Default	RGMII mode
			101	RTBI mode
			110	SGMII mode
			010,100,111	Reserved
22-27	Reserved	—	Must be cleared	
28	TLE	True little endian	0: Default	Big-endian mode
			1	True little endian mode
29	LALE	Local Bus ALE signal timing	0: Default	Normal LALE timing
			1	LALE is negated 1/2 lbc_controller_clk earlier.
30-31	Reserved	—	Must be cleared	

5.3 Power Supply

The MPC8313E RDB requires a power supply from the ATX power connector. The ATX supply connector directly provides 12-V, 5-V, and 3.3-V voltages. Core voltage, DDR2 voltage, RGMII voltage, and PHY-specific voltages are provided by either switching or linear regulated depending on the voltage drop and current consumption requirement. MPC8313E power-down mode is supported. A regulator that can be shut down is implemented for this purpose.

The MPC8313E does not require the core supply voltage and IO supply voltages to be applied in any particular order. However, during the power ramp up, before the power supplies are stable, there may be an interval when the IO pins are actively driven. After the power is stable, as long as PORESET is asserted, most IO pins are three-stated. To minimize the time that IO pins are actively driven, apply core voltage before IO voltage and assert PORESET before the power supplies fully ramp up.

Table 21 shows the power supply table.

Table 21. Power Supply Usage Summary

Voltage	Usage	Budget	Solution
1 V shutdownable	VDD, AVDD1	<1 A	MIC1510ETB+ regulator (3 A) with tracking
1 V	VDDC	<10 A	MIC1953EUB+ switching
1.2 V	VSC7385, 88E1111	1.75 A + 0.4 A	MIC37302 LDO (3 A)
1.8 V	DDR2	0.5 A + DDR chip x2pcs	MIC37302 LDO (3 A)
2.5 V	RGMII	0.2 A + 0.2 A + 0.2 A	MIC39100-2.5WS (1 A)
3.3 V	General IO	Variable	Direct from ATX Power

Table 21. Power Supply Usage Summary

Voltage	Usage	Budget	Solution
5 V	Switching power, PCI cards	0.5–1 A	Direct from ATX Power
12 V	None	Nil	Direct from ATX Power

5.4 Chip-Select Assignments and Memory Map

Table 22 shows an example memory map on the MPC8313E RDB for U-Boot in NOR Flash memory.

Table 22. Example Memory Map, Local Access Window, and Chip-Select Assignments

Address Range	Target Interface	Chip-Select Line	Device Name	Port Size (Bits)
0x0000_0000–0x07FF_FFFF	DDR2	MCS0#	DDR SDRAM (128 Mbyte)	32
0x8000_0000–0x9FFF_FFFF	PCI	Nil	PCI memory space (512 Mbyte)	32
0xE000_0000–0xE00F_FFFF	Internal bus	Nil	IMMR (1 Mbyte)	—
0xE200_0000–0xE20F_FFFF	PCI	Nil	PCI I/O space (1 Mbyte)	32
0xE280_0000–0xE280_7FFF	NAND Controller	LCS1#	NAND Flash window (32Kbyte)	8
0xF000_0000–0xF001_FFFF	Local bus	LCS2#	VSC7385 (128Kbyte)	8
0xFA00_0000–0xFA00_7FFF	Local bus	LCS3#	Read/write buffer (32Kbyte)	8
0xFE00_0000–0xFE7F_FFFF	Local bus	LCS0#	Boot Flash (8 Mbyte)	16

6 Getting Started

This section describes how to boot the MPC8313E RDB. The on-board flash memory is preloaded with a flash image from the factory. Before powering up the board, verify that all the on-board DIP switches and jumpers are set to the factory defaults according to the settings listed in [Section 6.1, “Board Jumper Settings,”](#) and make all external connections as described in [Section 6.2, “External Cable Connections.”](#)

CAUTION

Avoid touching areas of integrated circuitry and connectors; static discharge can damage circuits.

WARNING

Only the 3.3-V PCI Card is supported. Turn OFF power during insertion and removal of a PCI card.

6.1 Board Jumper Settings

Figure 41 shows the top view of the MPC8313E RDB with pin 1 marked for each reference. There are two DIP switches (S3, S4) and one jumper (J19). Their default settings are listed in Table 23.

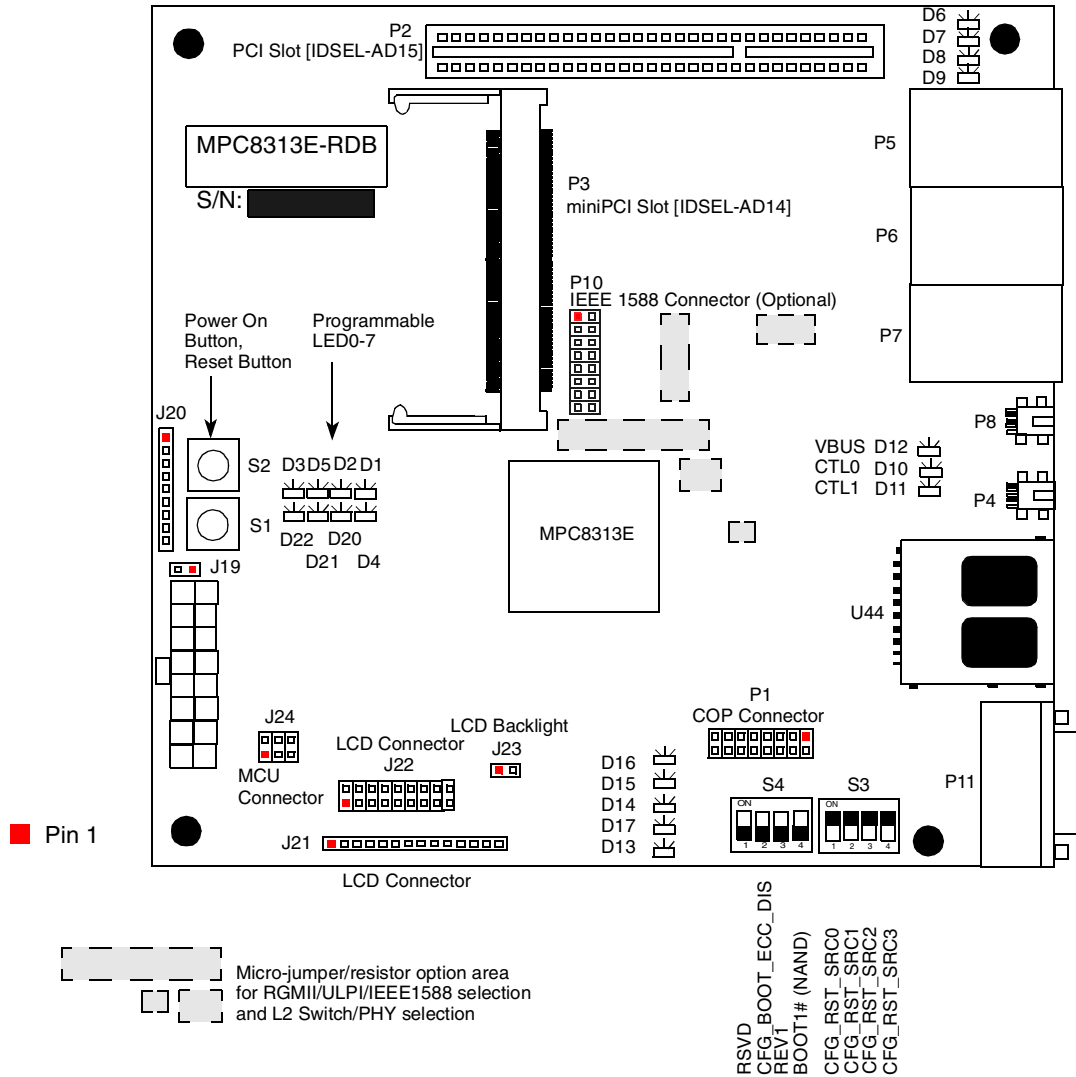

Figure 41. MPC8313E-RDB Top View

Table 23. Default DIP Switch and Jumper Setting

Reference	Default Setting
S3	0000 (all ON)
S4	1111 (all OFF)
J19	open (no jumper)

6.2 External Cable Connections

Do not turn on power until all cables are connected and the serial port is configured as described in [Section 6.3, “Serial Port Configuration \(PC\).”](#) Connect the serial port of the MPC8313E RDB system and the personal computer using an RS-232 cable as shown in [Figure 42](#).

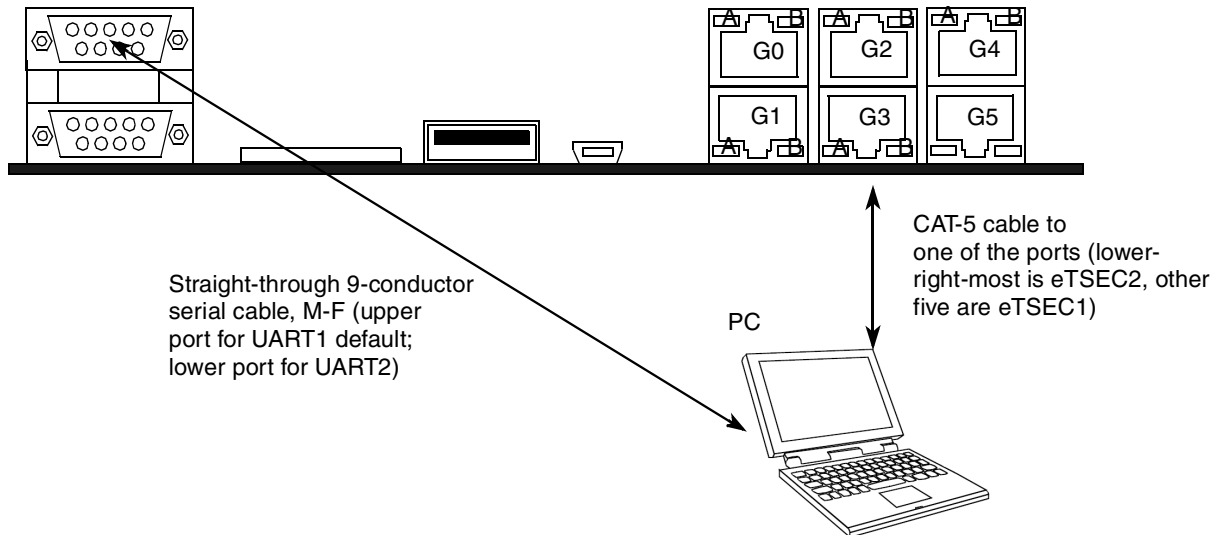

Figure 42. External Connections

6.3 Serial Port Configuration (PC)

Before powering up the MPC8313E RDB, configure the serial port of the attached computer with the following values:

- Data rate: 115200 bps
- Number of data bits: 8
- Parity: None
- Number of Stop bits: 1
- Flow Control: Hardware/None

6.4 Power Up

An ATX-type power connector (P9) should be used to supply necessary DC power to the MPC8313E RDB. It can be provided by an ATX-type power supply or from a mini-ITX case.

WARNING

Turn off the main power for the ATX power supply/mini-ITX case before the power connector is attached.

Power up the power supply. A few seconds after power up, the U-Boot prompt => should be received by the serial terminal program as shown here:

```
U-Boot 1.x.x (FSL Development) (Date - time) MPC83XX

Clock configuration:
  Coherent System Bus:  xxx MHz
  Core:                  yy MHz
  Local Bus Controller: xxx MHz
  Local Bus:             yy MHz
  DDR:                   xxx MHz
  ...
Hit any key to stop autoboot:  0
=>
```

NOTE

The normal function of the product may be disturbed by strong electromagnetic interference. If so, simply reset the product to resume normal operation by following the instructions in the manual. If normal function does not resume, use the product in another location.

7 MPC8313E RDB Software

A board support package (BSP) is pre-installed on the MPC8313E RDB. This BSP consists of a bootloader (U-Boot), a generic PowerPC Linux-based system, and an associated file system. U-Boot, the Linux kernel, and the file system reside in the on-board flash memory. At power up, the Linux system runs on the MPC8313E RDB.

The MPC8313E RDB BSP generation takes advantage of a tool called the Linux Target Image Builder (LTIB). LTIB is a suite of tools that leverages existing open source configuration scripts and source code packages and bundles them into a single BSP-generation package. The source code packages include boot loaders and Linux kernel sources as well as many user-space source code packages to build a complete BSP. LTIB also provides compiler packages required to build the BSP. Freescale developers use LTIB to create BSPs for a multitude of Freescale development targets. LTIB leverages as many BSP elements as possible for all Freescale-supported targets, and it offers the flexibility to customize components that require platform-specific modifications.

The MPC8313E RDB BSP release package contains a file named `MPC8313E RDB-<yyyymmdd>.iso`. This file is an ISO image that can be burned to a CD-ROM or mounted directly from your hard disk. Note that `<yyyymmdd>` is the release creation date. The LTIB installation script that installs all necessary packages on a host Linux PC and allows you to modify the BSP and packages within the BSP is in the `/ltib-MPC8313E-RDB` subdirectory within the ISO image.

This ISO image contains a file called `Readme.txt` that describes how to generate and install the BSP on the MPC8313E RDB hardware platform. `Readme.txt` contains the latest information for each BSP release. The ISO image also contains `Release Notes.txt`, which describes changes to the current BSP version versus earlier releases. To rebuild the BSP package or to add application software, carefully follow the instructions in `Readme.txt`. This file contains details on how to build, run, and install the BSP. It guides the

user to achieve a successful re-installation of the BSP on the MPC8313E RDB. This ISO image contains the following documents as well:

- MPC8313ERDEBUG.pdf. This user's guide document in PDF format.
- MPC8313E-RDB_schematic.pdf. The platform schematic in PDF format.
- SEC2SWUG.pdf. User's guide for the driver software of the security engine. This document details the driver software interface to boost the throughput performance of security applications such as IPsec.
- LtibFAQ.pdf. Frequently asked questions for LTIB, which is a useful document describing how to use LTIB to build the ISO image.

For more information on the MPC8313E RDB, visit the Freescale website listed on the back cover of this document. To run demonstrations or to acquire details of Freescale third-party applications for this MPC8313E RDB, contact your local Freescale sales office.

8 Frequently Asked Questions (FAQs)

Here are some commonly asked questions and their respective answers.

8.1 What are the differences among RDB revisions?

There are five revisions of the RDB, which are REVA, REVA1, REVA2, REVA3, REVA4, REVB and REVC. [Table 24](#) lists and describes these revisions.

Table 24. MPC8313E-RDB Revisions

Revision	Description
REVA	There are two major issues on the REVA board: <ul style="list-style-type: none"> • On-chip PHY USB signals (DP, DM) are swapped. To use the USB, use a USB cable that swaps the signals (the cable is attached in the REVA package). • NAND flash memory cannot be used as a boot device.
REVA1	Fixes both major issues on the REVA board. The boot-from-NAND on the REVA1 RDB has been verified. However, on the current BSP preloaded on REVA1 RDB, NAND flash memory is empty, so it is also not bootable. Booting from NAND flash memory will be supported in a future release of the BSP. Software for REVA and REVA1 differs only in the OR1[BCTLD] register setting for NAND flash memory. That is, REVA OR1[BCTLD] is 1; while REVA1 OR1[BCTLD] is 0.
REVA2	A minor update from REVA1 for mass production. It updates the silkscreen and adds a 12-V fan connector (J25) and resistor loading for ATX power. Software can be shared without modification between REVA1 and REVA2.
REVA3	Fixes the PMC register issue mentioned in Section 8.5, "Power management control (PMC) registers cannot be accessed?" Because of a processor erratum, a 166 MHz CSB frequency should be used. For this reason, some REVA3 and all later boards have 33 MHz instead of 66 MHz as the clock input (check your board U15 oscillator marking). The CORE/CSB/DDR frequency setting is 333/166/333 MHz. However, there are two drawbacks: <ul style="list-style-type: none"> • PCI bus can run at up to only 33 MHz • PCI/mini-PCI card can run at 66 MHz (has its M66EN pulled up) and should be used. Even the PCI bus on the RDB runs at only 33 MHz. Otherwise, the PCI frequency is further divided and it becomes 16.6 MHz.

Table 24. MPC8313E-RBD Revisions

Revision	Description
REVA4	Fixes the second drawback point of REVA3.
REVB	<ul style="list-style-type: none"> Added GTX_CLK125 sourced from external 125 MHz oscillator. Added an optional IEEE 1588 connector (P10). Added three more resistor options (R311–R313) to route 3 IEEE 1588 signals that only available in eTSEC1 to the IEEE 1588 connector. Changed S4 to support LB_POR_CFG_BOOT_ECC_DIS. Changed SD chip select signal from $\overline{\text{SPISSEL}}$(GPIO31) to GPIO13.
REVC	<ul style="list-style-type: none"> Added a Marvell 88E1111 PHY. Phy address assigned to 0x3. Use same IRQ3# as L2 Switch. Added resistor option for RGMII signals route to either to L2 Switch or Marvell 88E1111 PHY. Added SGMII support for eTSEC1 if using the added Marvell 88E1111 PHY. (SGMII for eTSEC2 already supported.) Added PLL CY23EP05SXC-1 U86 to PHY generated 125 MHz clock. Changed default TSEC1_GTX_CLK125 clock source to PLL CY23EP05SX-1 instead of external 125 MHz oscillator. Changed U36 1A linear regulator MIC39100-2.5WS to 3A MIC37302WR for higher 2.5V power consumption by additional PHY. Changed default DAC to 16-bit SPI controlled MAX5203BEUB+ (U47).

8.2 What should I do if the flash (NOR flash) image on the RDB is accidentally erased?

You should set the RDB to use a hardcoded reset configuration and reprogram the flash memory by debugger (for example, CodeWarrior debugger + USBTAP). To use a hardcoded reset configuration, set DIP switch S3 as OFF-ON-OFF-OFF (1011). On the other hand, if there is a reset configuration in NAND Flash or the I²C EEPROM, you may want to use either one as a hard reset configuration source.

Alternatively, some REVA3 and all later boards have the I²C EEPROM bootloader programmed. It can be used to reprogram the NOR Flash memory without a debugger. The procedure is as follows:

1. Power off the board and set DIP switch S3 as ON-OFF-ON-ON (0100).
2. Connect the board to Kermit (a UART terminal program; the other terminal program does not work at this mode). Kermit can be downloaded from <http://kermit.wwarthen.com/Download.htm>.
3. Set the baud rate in Kermit as 38400 bps (for a 66 MHz clock-in RDB) or 19200 bps (for a 33 MHz clock-in RDB).
4. Power on the board and you should see the following in Kermit:

```
Hello and welcome to I2C BOOTLOADER
## Ready for binary (kermit) download
```

5. Go to Kermit → Send and select the u-boot image binary to be written into flash memory.
6. Wait for the file transfer and flash programming until you see `success` in the Kermit window.
7. Power off the board and set DIP switch S3 back to ON-ON-ON-ON (0000).
8. Power on the board and you should see a running u-boot.

8.3 What is the hardware setting for boot from NAND Flash?

Set DIP switch S4 as OFF-OFF-OFF-ON (1110) and set DIP switch S3 as ON-ON-ON-OFF (0001). Note that there is no boot image on NAND flash memory with the default shipment.

8.4 Some ATX power supplies do not work with the RDB?

Some ATX power supplies may need a large 5-V loading to stabilize the 3.3-V output; otherwise, you may observe the 3.3 V lowered to around 2.9 V–3 V. The consequence can be a periodic reset by the on-board voltage monitoring circuit. For a workaround, you may take one of the following actions:

- Add a 5-V loading to the power supply, for example, attach a hard disk drive.
- Change to another ATX power supply that does not require a large 5-V loading.
- Use the power supply provided with the RDB package.

Starting from revision REVA2, a resistor loading for 5 V is added. It should work better with the ATX power supply that requires large 5-V loading. If there is still a problem, simply apply one of the workarounds presented here.

8.5 Power management control (PMC) registers cannot be accessed?

The PMC registers range from $IMMR + 0x0B00$ to $IMMR + 0x0BFF$. When this area is accessed in u-boot, the RDB hangs up. It appears that the PMC block is related to the JTAG interface; \overline{TRST} must not be pulled down for normal operation of the PMC block. Possible workarounds are as follows:

- Attach a debugger to drive \overline{TRST} high during normal operation.
- Remove the pull-down resistor (R37) for \overline{TRST} . Although this tested on some RDBs without any problem, it violates the hardware specification. If it does not work on your RDB, use another workaround.
- This problem is fixed in REVA3

9 Revision History

Table 25 provides a revision history for this document.

Table 25. Document Revision History

Rev. Number	Date	Substantive Change(s)
0	2/2007	Initial public release.
1	4/2007	Replaced a faulty table of contents and restructured sections of the document for clarity.
2	4/2007	Added information to Section 8, Frequently Asked Questions (FAQs)

Table 25. Document Revision History (continued)

Rev. Number	Date	Substantive Change(s)
3	3/2008	<ul style="list-style-type: none"> • Added GTX_CLK125 sourced from external 125 MHz oscillator. • Added an optional IEEE 1588 connector (P10). • Added three more resistor options (R311–R313) to route three IEEE 1588 signals that are only available in eTSEC1 to the IEEE 1588 connector. • Changed S4 to support LB_POR_CFG_BOOT_ECC_DIS. • Changed SD chip select signal from SPISEL(GPIO31) to GPIO13.
4	8/2008	<ul style="list-style-type: none"> • Added a Marvell 88E1111 PHY. Phy address assigned to 0x3. Use same IRQ3# as L2 Switch. • Added resistor option for RGMII signals route to either to L2 Switch or Marvell 88E1111 PHY. • Added SGMII support for eTSEC1 if using the added Marvell 88E1111 PHY. (SGMII for eTSEC2 already supported.) • Added PLL CY23EP05SXC-1 U86 to PHY generated 125 MHz clock. • Changed default TSEC1_GTX_CLK125 clock source to PLL CY23EP05SX-1 instead of external 125 MHz oscillator. • Changed U36 1A linear regulator MIC39100-2.5WS to 3A MIC37302WR for higher 2.5V power consumption by additional PHY. • Changed default DAC to 16-bit SPI controlled MAX5203BEUB+ (U47).

THIS PAGE INTENTIONALLY LEFT BLANK

How to Reach Us:

Home Page:

www.freescale.com

Web Support:

<http://www.freescale.com/support>

USA/Europe or Locations Not Listed:

Freescale Semiconductor, Inc.
Technical Information Center, EL516
2100 East Elliot Road
Tempe, Arizona 85284
+1-800-521-6274 or
+1-480-768-2130
www.freescale.com/support

Europe, Middle East, and Africa:

Freescale Halbleiter Deutschland GmbH
Technical Information Center
Schatzbogen 7
81829 Muenchen, Germany
+44 1296 380 456 (English)
+46 8 52200080 (English)
+49 89 92103 559 (German)
+33 1 69 35 48 48 (French)
www.freescale.com/support

Japan:

Freescale Semiconductor Japan Ltd.
Headquarters
ARCO Tower 15F
1-8-1, Shimo-Meguro, Meguro-ku
Tokyo 153-0064
Japan
0120 191014 or
+81 3 5437 9125
support.japan@freescale.com

Asia/Pacific:

Freescale Semiconductor Hong Kong Ltd.
Technical Information Center
2 Dai King Street
Tai Po Industrial Estate
Tai Po, N.T., Hong Kong
+800 2666 8080
support.asia@freescale.com

For Literature Requests Only:

Freescale Semiconductor
Literature Distribution Center
P.O. Box 5405
Denver, Colorado 80217
+1-800 441-2447 or
+1-303-675-2140
Fax: +1-303-675-2150
LDCForFreescaleSemiconductor@hibbertgroup.com

Information in this document is provided solely to enable system and software implementers to use Freescale Semiconductor products. There are no express or implied copyright licenses granted hereunder to design or fabricate any integrated circuits or integrated circuits based on the information in this document.

Freescale Semiconductor reserves the right to make changes without further notice to any products herein. Freescale Semiconductor makes no warranty, representation or guarantee regarding the suitability of its products for any particular purpose, nor does Freescale Semiconductor assume any liability arising out of the application or use of any product or circuit, and specifically disclaims any and all liability, including without limitation consequential or incidental damages. "Typical" parameters which may be provided in Freescale Semiconductor data sheets and/or specifications can and do vary in different applications and actual performance may vary over time. All operating parameters, including "Typicals" must be validated for each customer application by customer's technical experts. Freescale Semiconductor does not convey any license under its patent rights nor the rights of others. Freescale Semiconductor products are not designed, intended, or authorized for use as components in systems intended for surgical implant into the body, or other applications intended to support or sustain life, or for any other application in which the failure of the Freescale Semiconductor product could create a situation where personal injury or death may occur. Should Buyer purchase or use Freescale Semiconductor products for any such unintended or unauthorized application, Buyer shall indemnify and hold Freescale Semiconductor and its officers, employees, subsidiaries, affiliates, and distributors harmless against all claims, costs, damages, and expenses, and reasonable attorney fees arising out of, directly or indirectly, any claim of personal injury or death associated with such unintended or unauthorized use, even if such claim alleges that Freescale Semiconductor was negligent regarding the design or manufacture of the part.

Freescale™ and the Freescale logo are trademarks of Freescale Semiconductor, Inc. The Power Architecture and Power.org word marks and the Power and Power.org logos and related marks are trademarks and service marks licensed by Power.org. The PowerPC name is a trademark of IBM Corp. and is used under license. IEEE 1588 are registered trademarks of the Institute of Electrical and Electronics Engineers, Inc. (IEEE). This product is not endorsed or approved by the IEEE. All other product or service names are the property of their respective owners.

© Freescale Semiconductor, Inc., 2008. All rights reserved.

Document Number: MPC8313ERDBG

Rev. 4
02/2009

