

Everywhere you imagine. **RENESAS**

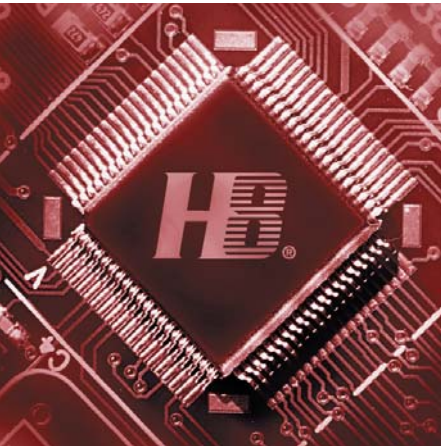

H8[®] Family of Microcontrollers



2006.8

Renesas Technology
www.america.renesas.com



In 2005, Renesas earned a **23%** share of the global MCU market — more than any other supplier — and an **11%** market share in the Americas (a 12% increase), according to Gartner Semiconductor Industry Worldwide Annual Market Share Database, March 31, 2006

**RENESAS
ACHIEVED
12%
MARKET SHARE
GROWTH IN THE
AMERICAS IN 2005!**

Renesas — Your Best Decision for Microcontrollers and Microprocessors

Choose for your next design; use for all your future ones.

Renesas Technology, the #1 global supplier of microcontrollers, offers hundreds of devices in our H8®, R8C/Tiny, M16C™ and SuperH® families, among others, that have solid technology roadmaps and cover wide spans of performance, integration, power efficiency and price points. Our advanced silicon solutions simplify system optimizations, facilitate design enhancements and diversifications, and help you meet tight cost budgets. You can shorten your system design cycles and improve your time-to-market by taking advantage of our total system support, which includes starter kits, HW/SW tools, reference designs/platforms, example software code, and middleware. Expert third-party support is available as well.



LEAD-FREE PACKAGING!

FOR THE LATEST INFORMATION ON LEAD-FREE PACKAGING AND ROHS COMPLIANCE, PLEASE VISIT OUR WEBSITE: <http://america.renesas.com/leadfree>

LET "MY RENESAS" SIMPLIFY YOUR WEB-BROWSING ACTIVITY

The "My Renesas" link in the header of all of our Web pages is a valuable and easily accessible resource. It lets you create a customized collection of links and data that simplifies and speeds your browsing.

Get timely updates on Renesas products, receive our latest news stories, and be alerted to software downloads and new web services as they become available. Register today to facilitate future data searches. It's free!

IMPORTANT!

- This document may, wholly or partially, be subject to change without notice.
- All rights are reserved: No one is permitted to reproduce or duplicate, in any form, the whole or part of this document without the express permission of Renesas Technology America, Inc.
- Renesas will not be held responsible for any damage to the user that may result from accidents or any other reasons during the operation of the user's unit according to this document.
- Circuitry and other examples described herein are meant merely to indicate the characteristics and performance of Renesas semiconductor products. Renesas assumes no responsibility for any intellectual property claims or other problems that may result from applications based on the examples described herein.
- No license is granted by implication or otherwise under any patents or other rights of any third party or Renesas Technology Corp.
- MEDICAL APPLICATIONS:
Renesas products are not authorized for use in MEDICAL APPLICATIONS without the written consent of the appropriate officer of Renesas' sales company. Such use includes, but is not limited to, use in life support systems. Buyers of Renesas products are requested to notify the relevant Renesas sales officers when planning to use the products in MEDICAL APPLICATIONS.

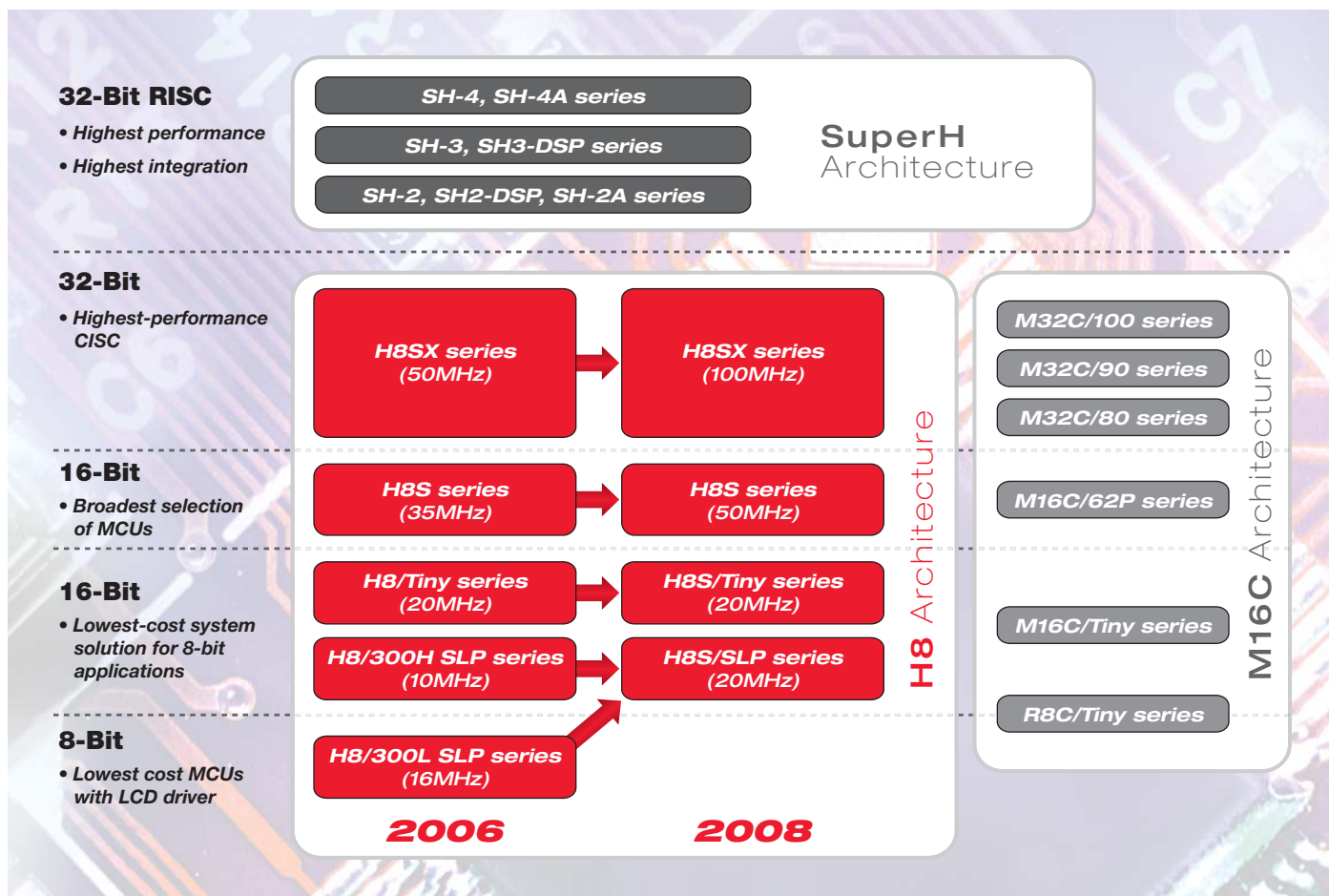

Market Needs	Renesas H8 Solutions
High performance	Speeds up to 50MHz, providing 50MIPS with single-cycle flash access
Wide range of programmable memory	Single-voltage-programmable on-chip flash — 8KB to 1MB
Wide range of low-cost memory	Mask-ROM versions for many flash MCUs — 2KB to 512KB
Integrated peripherals, including support for industry-standard interfaces	Devices in the H8 series offer more than 100 different on-chip peripherals <ul style="list-style-type: none"> • Match peripheral set to application • Choose from timers, A/Ds, D/As, on-chip oscillators, low-voltage detect, and DMA functions, among many others • UART, SPI, I²C, IrDA, CAN, LIN, USB, Smart Card, LCD, POR, etc.
Low power consumption	<ul style="list-style-type: none"> • Super-low-power CMOS technology — 200µA @ 1MHz, 0.4µA @ 32kHz • Up to eight power-down modes • 32kHz sub-clock oscillator
Low radiation noise	Improved technology and design techniques for a 20dB reduction in noise compared to conventional products
Development environment	<ul style="list-style-type: none"> • Fully integrated tool suite of H/W and S/W tools • Highly optimized Renesas C/C++ compiler • 100% upward code compatibility
Cost/performance	Best in the industry
Support and training	<ul style="list-style-type: none"> • Experienced application engineers • Training courses and development tools available online at www.renesasinteractive.com

The H8 Family Roadmap

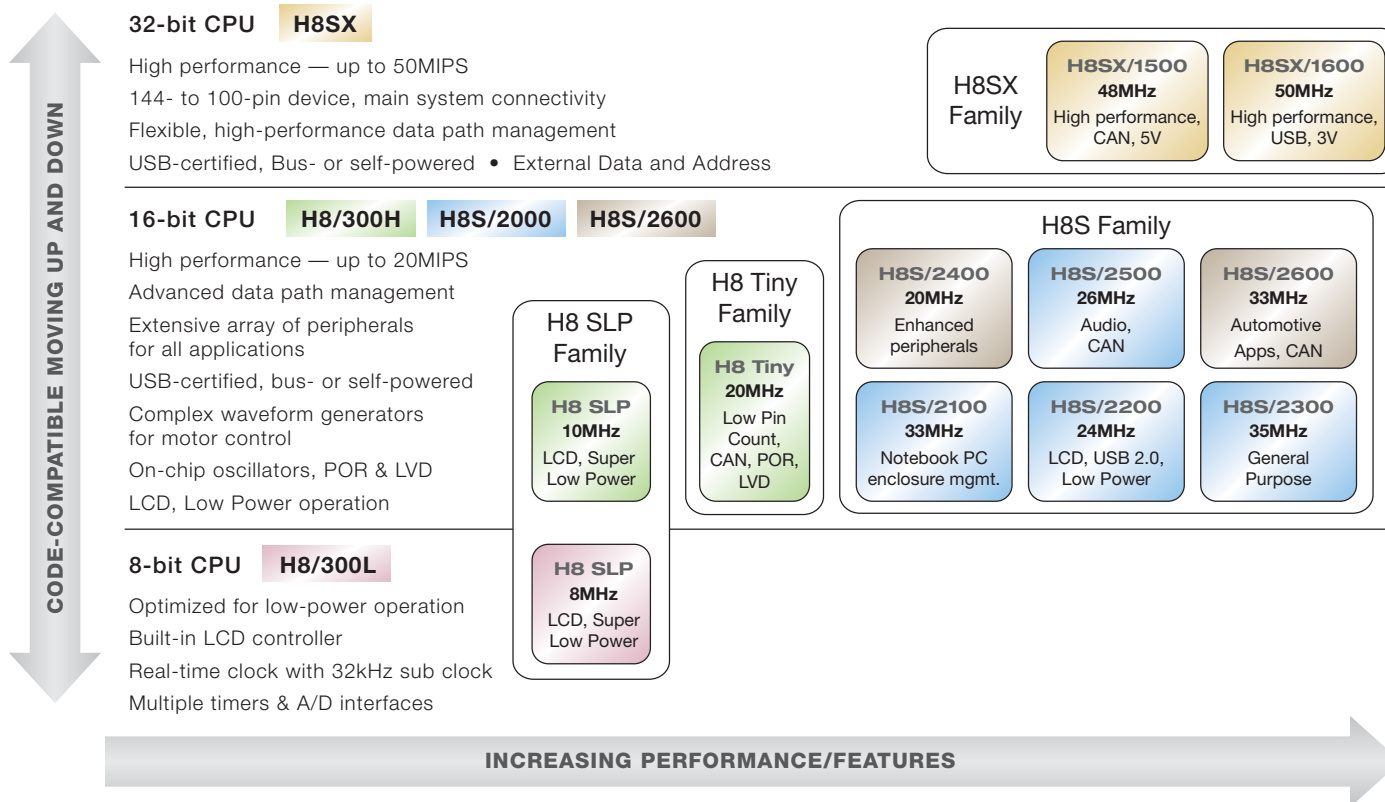

Renesas Technology America, Inc. is a leading supplier of 8/16/32-bit microcontrollers (MCUs) and microprocessors. The cost-competitive Renesas MCUs in the H8® family are ideal for low-power, high-performance embedded systems in consumer, industrial, medical, communication and automotive applications.

MCU Series in the H8 Family

The H8 microcontroller family encompasses a wide range of devices, from 8-bit low-cost, super-low-power, low-pin-count MCUs to 32-bit high-performance devices. Upward code compatibility is maintained in the various H8 MCU series.

The **H8/300L** and **H8/300H** super-low-power (SLP) MCUs are excellent solutions where battery life is critical.

The **H8 Tiny** series devices provide the performance of 16-bit MCUs, yet are economical enough for many 8-bit applications.

The **H8S/2100** series includes a device with multiple serial interfaces that are optimized for enclosure management control in PC/Server (IPMI) and notebook applications. This family includes certified high-speed USB functionality.

The **H8S/2200** series MCUs include devices with a USB v2.0-compatible interface (Bus or Self powered) and devices with a 40-segment LCD controller that's a great match for low-cost PC peripherals, metering instruments, and medical diagnostic equipment.

The **H8S/2300** series MCUs provide many device choices for optimizing system cost, performance and features.

The **H8S/2400** series MCUs have enhanced peripherals for use with LCD monitors and other home electronics.

The **H8S/2500** series MCUs are designed for audio and automotive applications. This series features multiple serial ports, I²C and CAN, and includes selectable 3V and 5V signaling on the GPIO lines.

The **H8S/2600** series MCUs have on-chip HCAN (Hardware Controller Area Network) controllers and are top choices for automobile and industrial applications.

The **H8SX** series MCUs provide a 32-bit performance upgrade path for the H8 family, maintaining code compatibility and offering a rich set of on-chip peripherals.

H8 Series MCU Product Overview

H8 Series	CPU	MHz	Address Space	Features / Remarks	Applications
H8/300L SLP	8-bit	8	64KB	Super low power, LCD driver, Low-Voltage Detect, Power-On Reset	Utility meters, glucose meters, battery-powered security devices, home electronics, HVAC controls
H8/300H SLP	16-bit	10	16MB	Super low power, LCD driver with voltage boost, 14-bit ADC, 1.8V Flash, 0.5 μ A @ 32kHz	Thermostats, HVAC, glucose meters, security sensors, building automation, lawn sprinkler control
H8/Tiny	16-bit	20	16MB	Low pin count, smaller package, POR, LVD, CAN, LIN, SPI	White goods, home electronics, automotive control systems, controller for small motors
H8S/2100	16-bit	33	16MB	LPC bus interface, multiple I ² C busses, PS/2 interface, multiple PWM, 16-channel ADC, high-speed USB	Notebook PC power management, enclosure management for servers/routers, IPMI applications, USB digital cameras
H8S/2200	16-bit	24	16MB	Low power, LCD controller, USB v2.0, I ² C, smart card interface	PC peripherals, barcode scanners, medical equipment, HVAC, utility meters, electronic point-of-sales equipment
H8S/2300	16-bit	35	16MB	Smart card interface, DMA controller, SDRAM interface	General applications, label printers, GPS systems
H8S/2400	16-bit	20	16MB	Low power, hardware multiplier, I ² C, enhanced timers, multiple serial channels	LCD monitors, LCD-TVs, plasma-TVs, projectors, home electronics
H8S/2500	16-bit	26	16MB	Low power, 3V and 5V I/Os, enhanced communication channels	Audio, automotive audio
H8S/2600	16-bit	33	16MB	HCAN, H/W MAC, smart card interface, PC break controller, DMA controller, SDRAM interface	Airbag controllers, tire pressure monitors, power steering controllers, pump controllers, siren controllers
H8SX/1500	16-bit	48	16MB	Fast multiply and divide, enhanced bit manipulation, CAN	Automotive body control
H8SX/1600	32-bit	50	4GB	Fast multiply and divide, enhanced bit manipulation, USB, SDRAM interface	ePOS, barcode scanners, printers, fitness equipment, USB devices

A Global Leading Position

Renesas Technology has acquired an impressive reputation for leadership and earned a large share of the embedded processor market growth areas of industrial and commercial applications. For example, H8S/2100 devices have gained about a 70% worldwide share of microcontrollers used in PC Server power management.



H8 MCUs: Fully Upward Compatible

H8 CPUs are all CISC-based (Complex Instruction Set Computation), developed to allow compatibility up and down the various H8 series. This makes it easy to move between the product lines in the H8 family.

The CPUs within the H8 family range from 8-bit, low-power optimized cores, to full 32-bit high-performance cores that achieve 1MIPS/MHz.

Benefits of H8 CPU cores include:

- Most instructions execute in one clock cycle
- Built-in hardware MAC (H8S/2600 and H8SX only)
- Fast multipliers and dividers
- Enhanced memory addressing schemes (memory-to-memory access, one instruction)
- Advanced conditional branching instructions
- Powerful CISC instructions with small code size

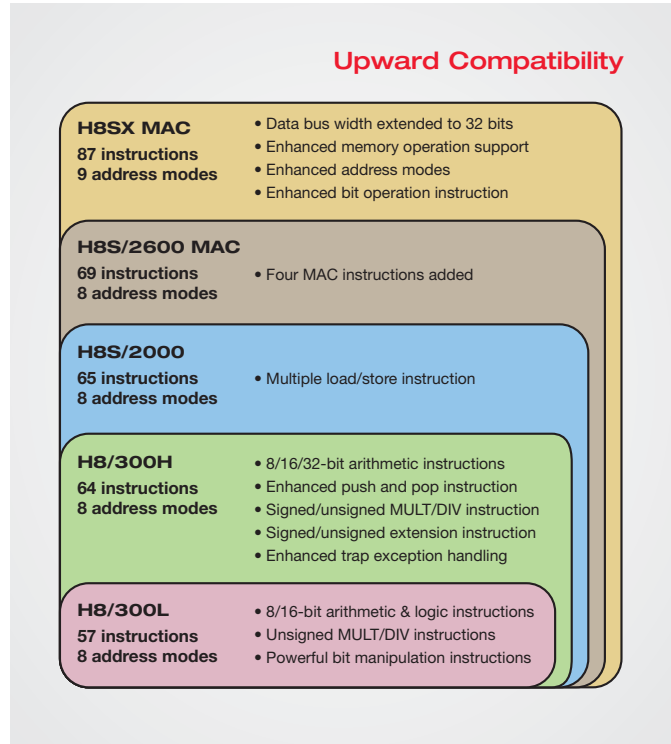

H8 CPU Register Set Diagram

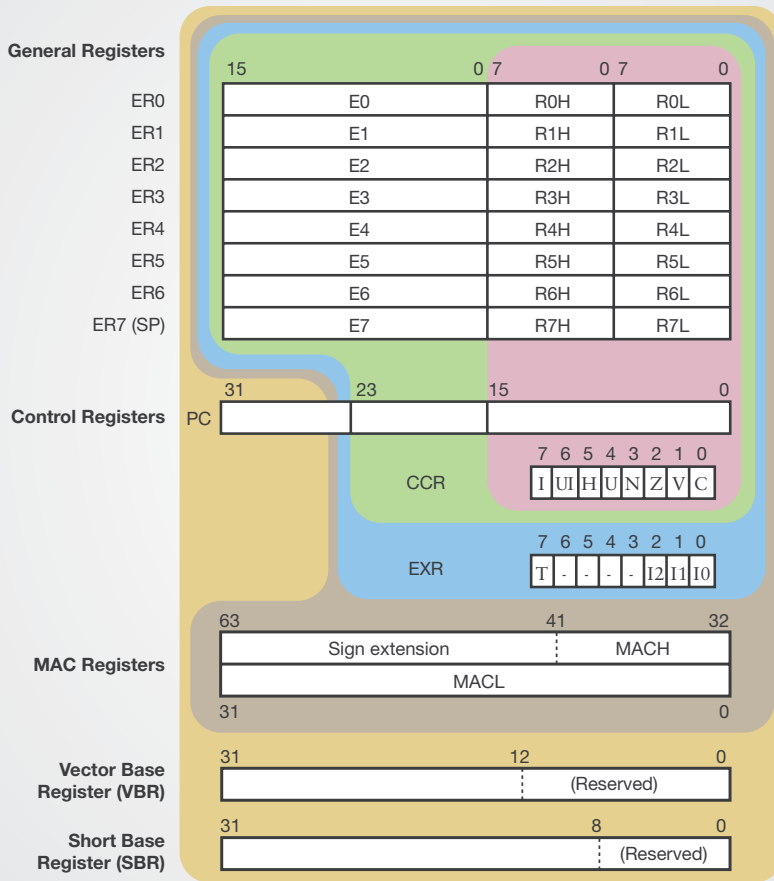

CPU Register Set

The CPUs within the H8 family are designed from the same register set, allowing complete compatibility.

H8/300L devices use 8 general-purpose registers as 8 and 16 bits. PC is 16 bits wide.

H8/300H devices use 8 general-purpose registers as 8, 16 and 32 bits. PC is 24 bits wide.

H8S/2000 devices use 8 general-purpose registers as 8, 16 and 32 bits. PC is 24 bits wide.

H8S/2600 devices use 8 general-purpose registers as 8, 16 and 32 bits. PC is 24 bits wide. Hardware MAC.

H8SX devices use 8 general-purpose registers as 8, 16 and 32 bits. PC is 32 bits wide. Hardware MAC. VBR and SBR available.

H8 MCUs: Faster Execution Times

Besides maintaining compatibility within the family, H8 CPUs have been optimized for high performance.

The majority of the instructions in the powerful CISC instruction set will execute in one clock cycle, giving RISC-like operation.

Enhanced Hardware for Performance

Enhanced multipliers and dividers are included in the CPU core to boost throughput for mathematical operations and further enhance the performance of the CPU cores.

The H8S/2600 and H8SX CPU cores each have a hardware MAC (Multiply and Accumulate) block for extra performance in applications that involve data computations.

H8 Family CPU Core Overview

	H8/300	H8/300H	H8S/2000	H8S/2600	H8SX
Basic Instructions Execution	2 cycles	2 cycles	1 cycle	1 cycle	1 cycle
Bus Width	8-bit	16-bit	16-bit	16-bit	32-bit
No. of Instructions	57	64	65	69	87
Address Space	64KB	16MB	16MB	16MB	4GB

Advanced Multiplier execution cycles

Instruction	H8S	H8SX
MULXU.B	3	1
MULXU.W	4	1
MULXS.B	4	2
MULXS.W	5	2
MULU.W	-	2
MULU.L	-	5
MULS.W	-	2
MULS.L	-	5
MULU/U.L	-	6
MULS/U.L	-	6
CLRMAC	1	1
LDMAC	1	1
STMAC	2	1
MAC	4	4

Advanced Divider execution cycles

Instruction	H8S	H8SX
DIVXU.B	12	10
DIVU.W	-	10
DIVXU.W	20	18
DIVU.L	-	18
DIVXS.B	13	12
DIVS.W	-	11
DIVXS.W	21	20
DIVS.L	-	19

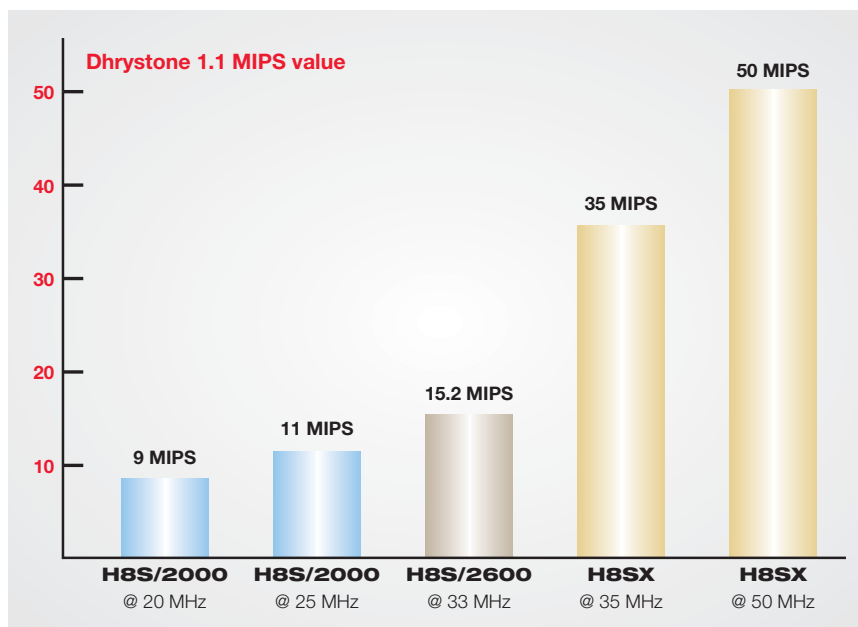

H8 MCU System Performance

H8 microcontrollers are designed to deliver high throughput for excellent application performance.

For example, their CISC CPU cores execute most instructions in just one clock cycle, and their Advanced Data Management peripherals utilize a 3-bus architecture to speed data transfers.

Also, the on-chip Flash can be accessed in a single cycle, achieving the best possible performance per MHz.

TOP REASONS TO SELECT H8

■ Renesas: The #1 Flash MCU supplier

- Renesas, the world's #1 supplier of flash, has shipped over 1 Billion flash MCUs
- Wide range of sizes of highly reliable F-ZTAT (flash) up to 1MB, in 0.18µm process
- Fastest flash write time: 2.5 sec./ 128KB for 0.18µm process
- Access as fast as 10ns @ 100MHz
- Up to -40°C to +125°C range
- Multiple user-friendly modes for programming/reprogramming flash memory
- User mode allows flash to be programmed or erased by user application software

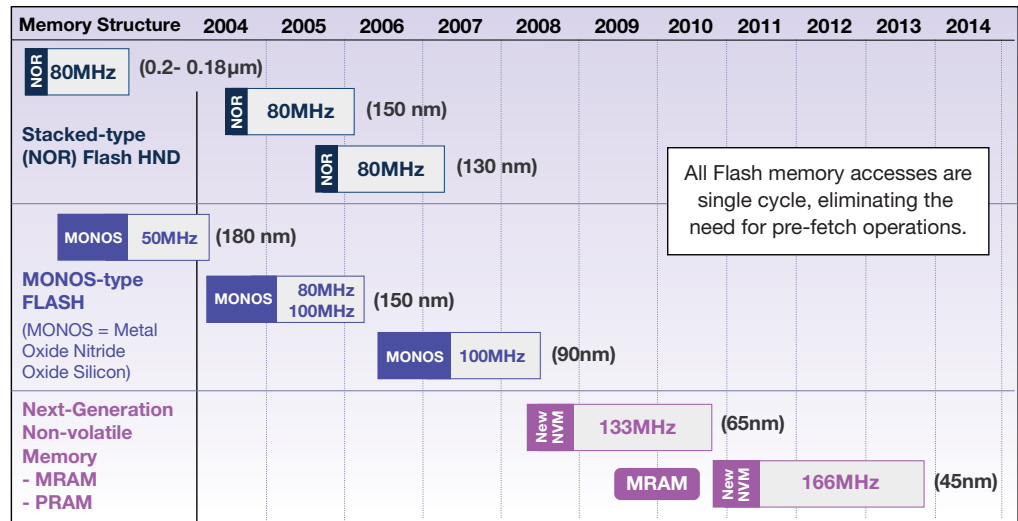

- Boot mode allows in-system programming using RS-232 serial port
- USB devices can be optionally programmed via the USB port
- User Boot mode allows storing a custom flash update routine in a special protected area
- Write mode enables MCU programming with desktop or production programmers
- Flash can be programmed via the on-chip debug emulator

Powerful Data Path Management

H8 products are fully optimized system solutions, so besides powerful CPU core processing, H8 MCUs have advanced data path management.

There are three types of data movement engines: System DMA, External DMA and Data Transfer Controller. The Advanced Bus System Controller manages complex data and control across the multiple-bus architecture.

The H8S and H8SX MCU architectures use 3 separate buses. Data movement on the External Bus and System Bus can operate in parallel, greatly increasing system performance by optimizing operation per clock cycle.

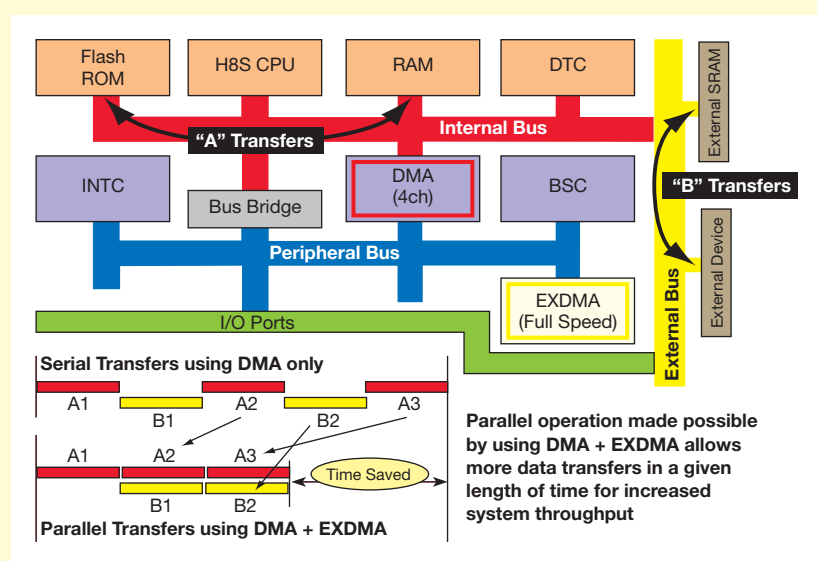

This example shows system operation (red) using the System DMA, while in parallel the External DMA is transferring data between an external device and the MCU (yellow). This parallel operation reduces time for operation.

TOP REASONS TO SELECT H8

■ On-chip Memory (SRAM)

- Many sizes of on-chip high-speed SRAM: 256 Bytes to 56KB
- 8KB of JTAG debug memory can be used for system op. (allowing 64KB on-chip SRAM)
- Single-cycle access at maximum speed

■ Low Power Consumption

Multiple innovative techniques minimize MCU power consumption

- 0.4 μ A @ 32kHz
- Operating voltages as low as 1.8V
- Up to 8 power-down modes
- Module Standby mode allows software to selectively halt on-chip functions
- Dual clock oscillators with 32kHz sub-clock
- On-chip oscillators
- Short oscillator stabilization times (20 μ s, typically)
- Standby current as low as 0.1 μ A

H8 Power Consumption: H8/38602

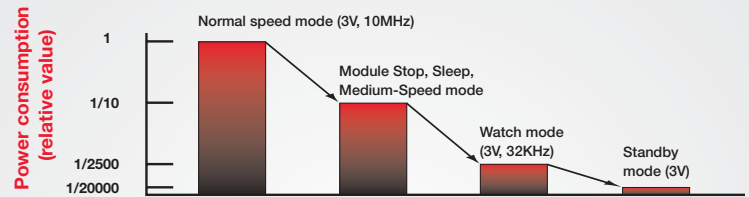

Shorter Crystal Stabilization Time

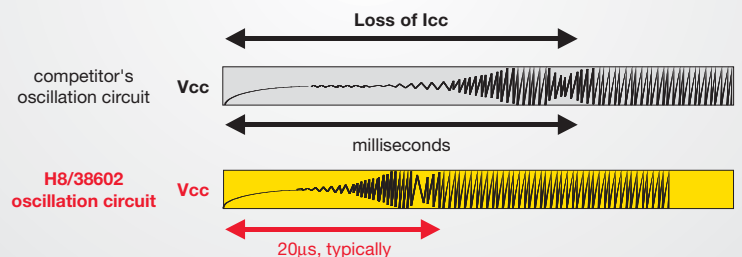

High component integration reduces system cost and design complexity

- On-chip oscillators as fast as 20 MHz available to CPU and all peripherals
- Low-voltage detect circuits to monitor power supplies efficiently without additional components
- Power-on Reset circuit eliminates external chip and guarantees a clean and reliable start-up
- High-current I/Os can drive LEDs directly
- LCD controllers with booster circuits drive higher voltage displays without the need of DC-DC converters
- Internal voltage regulators eliminate need for expensive power circuits
- Large range of internal reliable flash memory & high-speed RAM that suffice for most system requirements

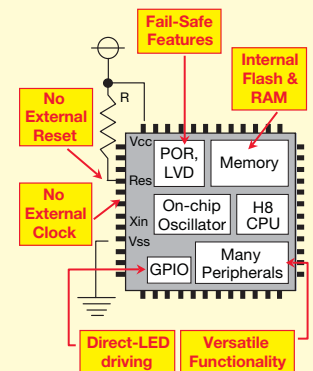

Industry-standard Serial Communication Interfaces

- Certified USB full-speed and high-speed; bus- or self-powered
- Multiple channels of serial asynchronous/synchronous interface
- Synchronous serial unit (SSU) is compatible with Freescale (Motorola) SPI™
- I²C™ two-wire serial interface conforms to Phillips standard
- IrDA interface for easy wireless line-of-sight connectivity
- Smart Card interface conforms to ISO/IEC 7816-3
- Controller Area Network (CAN 2.0B) function for highly reliable networked embedded systems

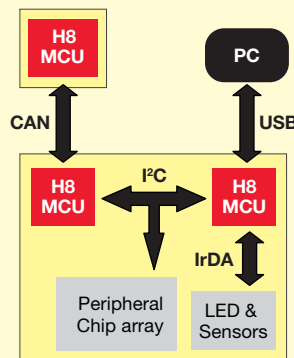

■ LCD Controller

- Option for using on-chip or external power supply
- Built-in LCD RAM (up to 128 bits) with byte or word access
- Supports multiple duty cycles: static, 1/2, 1/3, or 1/4

■ Universal Serial Bus

- Provides v2.0 support
- Offers full-speed, 12Mbps communication
- Offers high-speed, 480Mbps communication (H8S/2170)
- Bus-powered mode or self-powered
- Up to 9 endpoints can be specified
- Four transfer modes supported: Control, Interrupt, Bulk, and Isochronous
- On-chip bus transceiver with option for using external transceiver
- Total 1280-Byte FIFO buffer

■ Hardware Controller Area Network (HCAN) Function

- Fully compatible with Bosch v2.0B specification
- Ideal for automobile and industrial applications
- Bi-directional 2-wire serial communication
- Maximum speed up to 1Mbps
- Data length: 0 to 8 bytes
- Number of channels: 1 or 2
- Two data transmission methods:
 - Mailbox (buffer)
 - Message priority (identifier)
- Supports 12 CPU interrupts
- Supports 6 operating modes

LCD Block Diagram: H8/38099

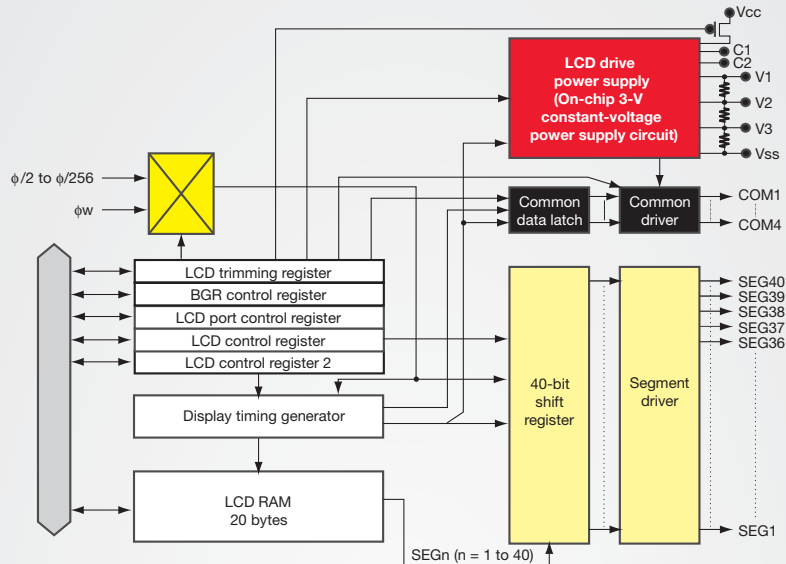

USB Block Diagram: H8S/2215R

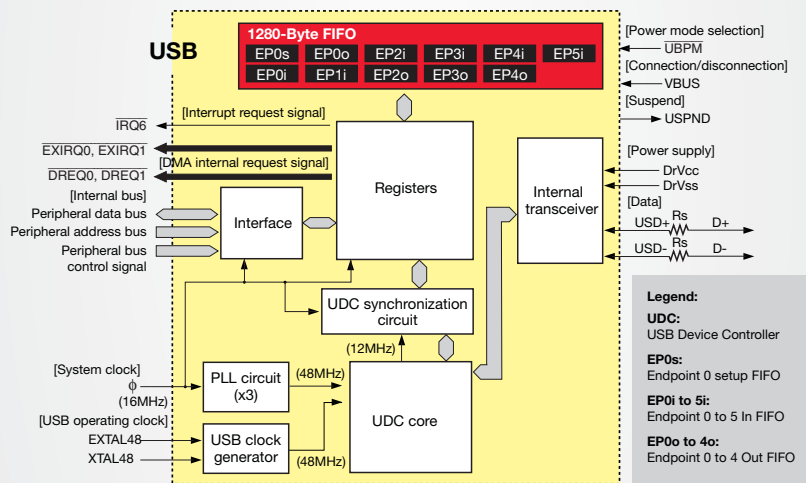

HCAN Block Diagram

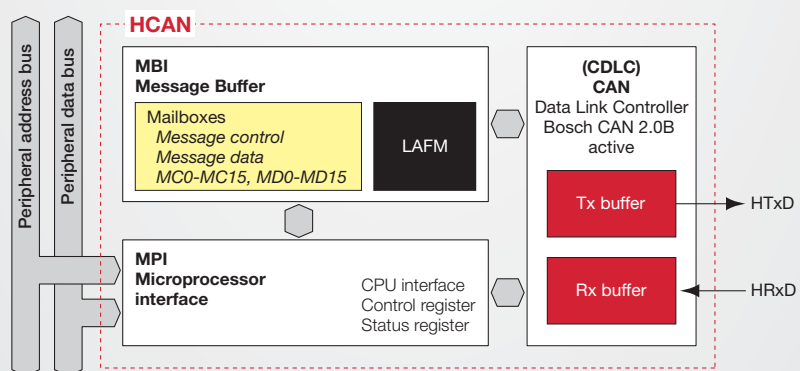

■ DMA Controller (DMAC)

- Max. of 4 channels can be used
- Dual-address or single-address mode can be selected
- Supports Single, Burst, Sequential, Idle and Repeat Transfer modes
- Data can be transferred in word or byte units
- Activation: internal interrupt, external request, auto-request

■ Data Transfer Controller (DTC)

- Max. of 85 channels can be used
- Multiple transfers or multiple types of transfers possible for one activation source
- Supports Single, Burst, Chain and Repeat Transfer modes
- Data can be transferred in byte or word units
- Activation sources: interrupt and software

■ External DMA Controller (ExDMAC)

- Max. of 4 channels can be used
- Selection of byte or word transfer data length
- Transfer data in parallel with CPU or other internal bus master
- Dual-address or single-address mode can be selected
- Supports Single, Burst, Sequential, Idle and Repeat Transfer modes
- Data can be transferred in word or byte units
- Activation: internal interrupt, external request, auto-request

DMA Controller Block Diagram

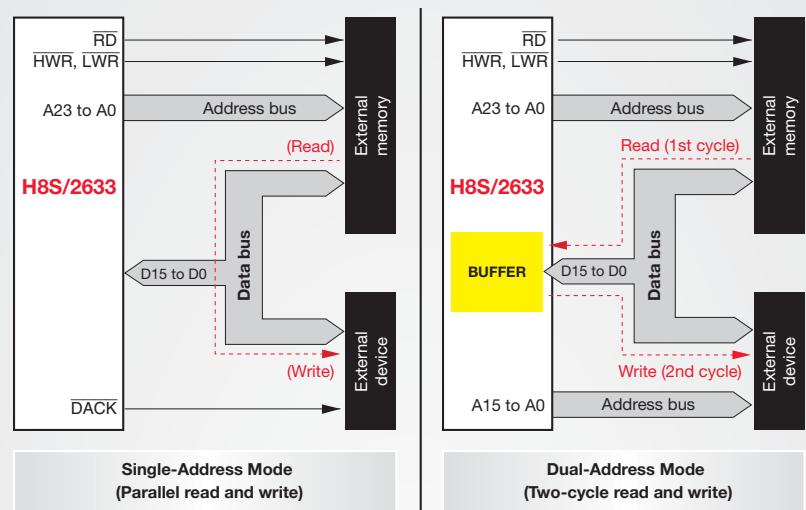

Data Transfer Controller: Chain Transfer Mode

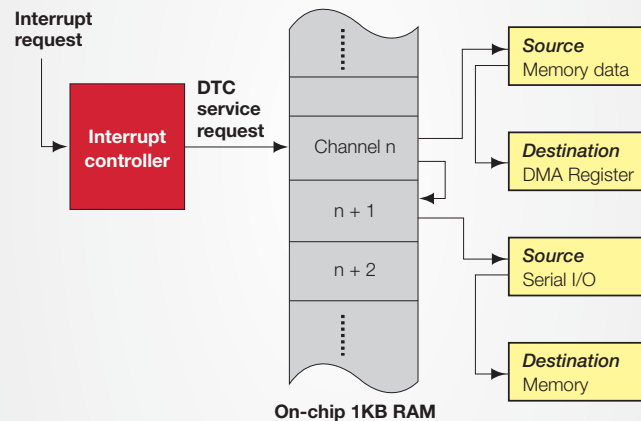

ExDMA Controller Block Diagram

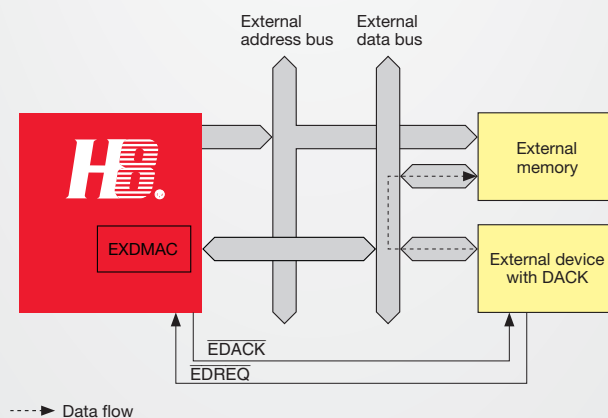

■ Analog Interfaces

- 4- to 16-channel 10-bit successive-approximation A/D converter (ADC)
- 2-channel, 14-bit delta-sigma ADC
- 2- to 4-channel 8-bit D/A converter

■ Timers

- Rich suite of 8-bit and 16-bit multifunction, multipurpose timers
 - Input capture, output compare, auto reload, event counter, up/down counter, interval timer, and sleep mode timer
- 3-phase Motor Control Timer
 - 2-phase encoder with up/down count capability
 - Suitable for motor control apps
- Asynchronous Event Counter (AEC)
 - Counts events even when system clock is disabled for power saving
- Watchdog timer (WDT) with independent RC circuit for greater safety
- 10-bit or 14-bit Pulse Width Modulation (PWM) timer with ripple-reduction feature
 - Can be used as a D/A converter by adding an external low-pass filter
- Real-Time Clock (RTC): seconds, minutes, hours, days and weeks

■ Arbitrary Waveform Generation / Programmable Pulse Generator (PPG) / Timing Pattern Controller (TPC)

- Arbitrary waveform patterns are stored in memory and generated on output pins with the PPG or TPC in conjunction with a timer and DMA
- Provides 8/16-bit programmable pulse outputs using TPU as base
- Output trigger signals can be selected in 4-bit groups
- Each group can operate both simultaneously and independently
- Output trigger signals can operate in parallel with DTC and DMAC

H8/38086 14-bit Delta-Sigma A/D

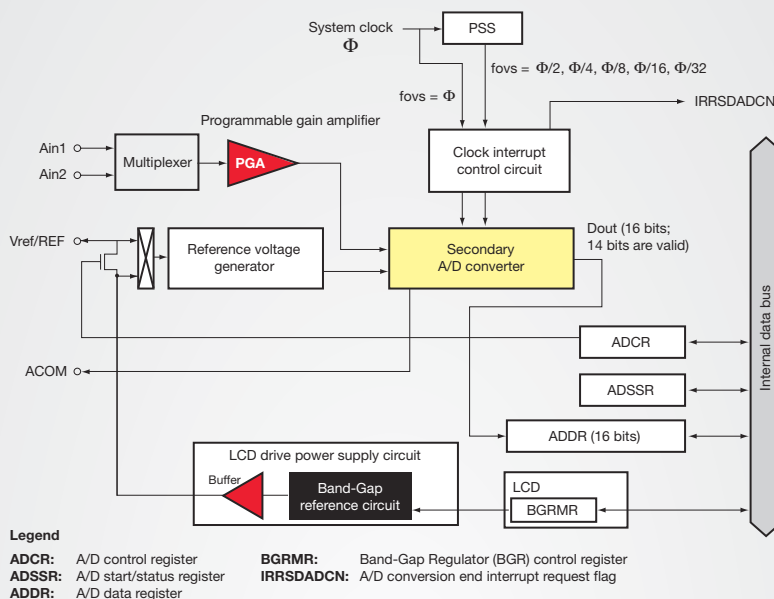

H8/Tiny 14-Bit PWM Timer Block Diagram

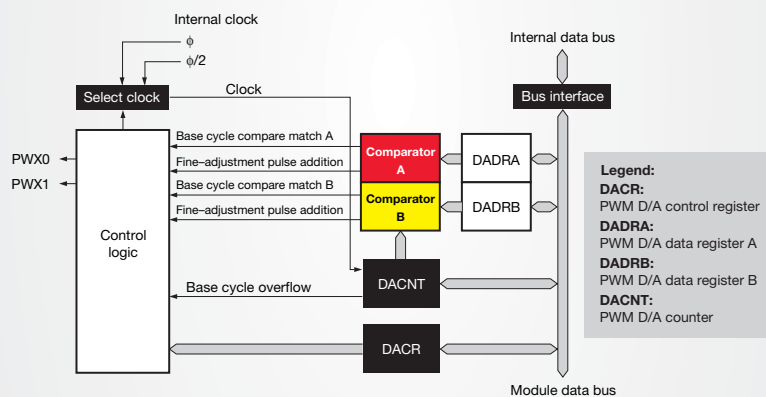

H8S 32K Sleep Mode Timer Block Diagram

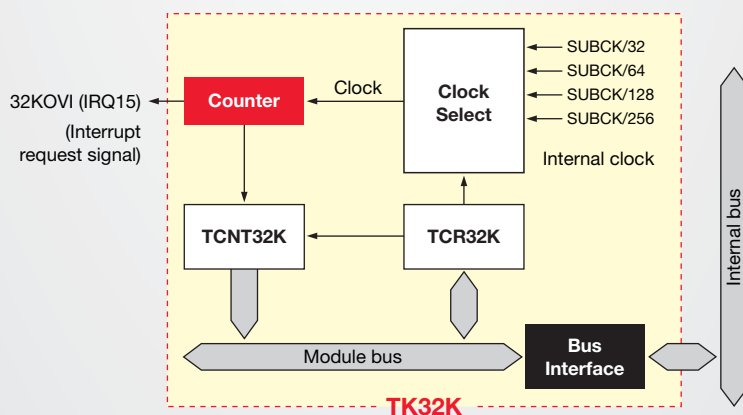

■ Low-Pin-Count (LPC) Interface

- A popular interface to communicate to PC chip set used in notebooks and PC servers
- Performs serial data and address transfer using 33MHz clock
- Supports I/O read and write cycles
- Supports serial interrupt on single line
- Supports power-down mode
- Reduced pin count

■ Host Interface X-Bus Interface

- Enables connection to the ISA (X-BUS)
- Four channel parallel interface
- Five host interrupt requests

■ Keyboard Buffer Controller (KBC)

- Conforms to PS/2 specification
- Error detection, parity error and stop bit monitoring
- Five host interrupt requests

■ PC Break Controller (PBC)

- Simplifies program debugging
- Instruction and data compare

■ Dual-Tone Multi-Frequency (DTMF) Generator

- Generates DTMF frequency sine waveform, with minimum distortion
- Synthesis of single waveform

■ On-chip Bus Controller (BSC)

- Provides glueless interface with external devices
- Supports basic SRAM, burst-ROM interface
- Manages external, addressable 16MB region (8 different areas)
- Bus specification can be set independently for each region
- Selectable 8- or 16-bit bus width
- Choice of 0 to 7 programmable wait-state access
- Supports direct connection to SDRAM on selected devices
- Includes a bus arbiter for bus mastership arbitration

PC Break Controller Block Diagram

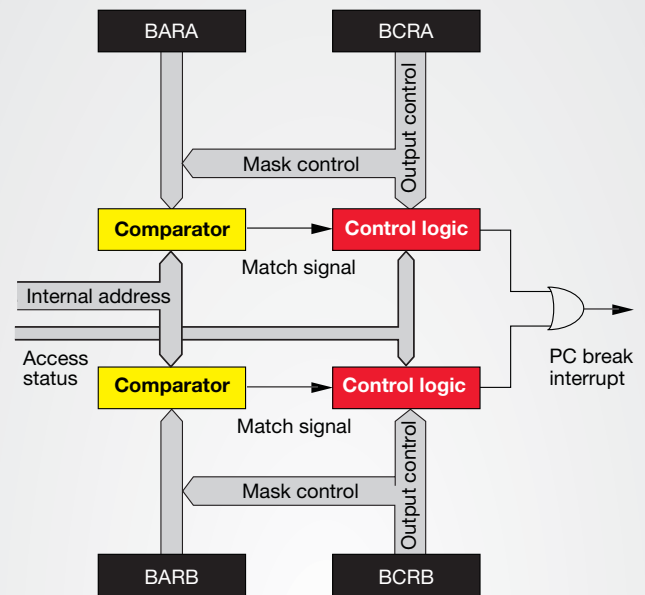

DTMF Application Usage

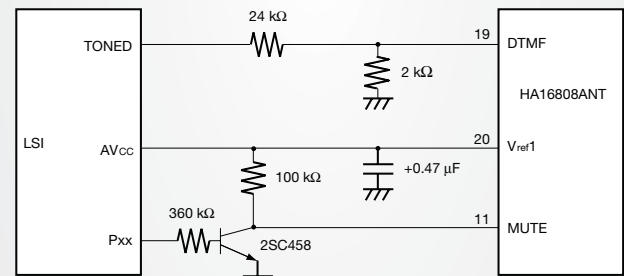

Note: The numeric values on the right end of the signal lines indicate the HA16808ANT pin numbers.

TONED Pin Output Equivalent Circuit

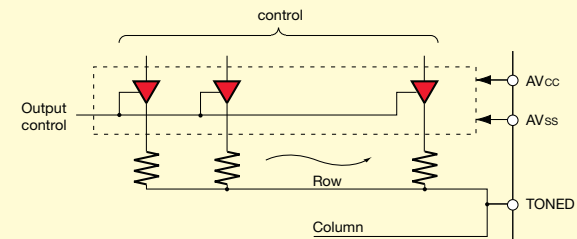

- Burst ROM interface can be set for area 0
- External write cycle and internal access can be executed in parallel
- Idle-cycle insertion capability

■ Overview

Renesas and the many third-party suppliers in the H8 community provide a wide range of hardware and software tools and other support services. Renesas offers products that cover all stages of the development of embedded systems that use H8 microcontrollers.

- **Evaluation**—Low-cost or no-cost Renesas tools make it easy to discover the capabilities of H8 MCUs and test the problem-solving power of the tools themselves, including the High-performance Embedded Workshop (HEW) integrated software development and debugging environment. A freely downloadable evaluation version of HEW lets you evaluate the ability of the Renesas C/C++ compiler to generate efficient code, and evaluation boards enable you to immediately test that code on known working hardware. In addition, the Renesas Interactive online engineering laboratory lets you use your own PC to get hands-on experience with powerful software and hardware tools and experiment with MCUs before purchase.
- **Debugging**—When you begin working on the design of your system, you can develop code using the full, unlimited compiler in exactly the same HEW environment. To track down bugs, use Renesas’ on-chip and full in-circuit emulators, which have powerful specialized debugging hardware for trapping specific conditions and recording program activity.
- **Final Programming**—Use Renesas’ Flash Development Toolkit, which has an easy-to-use interface, to program your debugged application into any of the many H8 MCUs that incorporate Renesas’ mature on-chip flash memory technology.

All the tools required for developing H8-based applications are available from Renesas distributors. These tools have been developed by groups within the worldwide Renesas organization, experienced engineers who have access to the designers of the devices themselves. Their insight and expertise ensures the best possible tool performance and support.

■ Software

Renesas’ integrated development environment

The High-performance Embedded Workshop (or HEW) is a graphical development environment for C/C++ compiler toolchains with an industry-standard look and feel. Through the use of menus, toolbars, status bars, dockable windows and context-sensitive local menus, HEW integrates key capabilities that can help you create and manage your embedded microcontroller software projects. Its capabilities include:

- Project creation and editing
- Graphical configuration of compiler tools
- Project Make
- Debugging
- Version control

HEW provides enhanced functionality and an integrated instruction simulator that allows you to debug application code even when hardware isn’t available. Also, the C/C++ compiler toolchains bundled with HEW generate code that executes faster and/or takes less memory space on Renesas microcontrollers.

One familiar interface, many functions

You can quickly learn the powerful tools you need for developing application code, and you have easy-to-use control over those tools.

Moreover, you can work with an interface that remains consistent across the entire range of Renesas MCUs and MPUs for greater efficiency. The interface is also highly customizable, so you can create an even more efficient environment for developing your application.

Wizards simplify start-up processes

You can start projects fast by taking advantage of HEW’s Project Generator “Wizards.” Let them guide you through the selection of configuration options, debugger targets, and the creation of startup code.

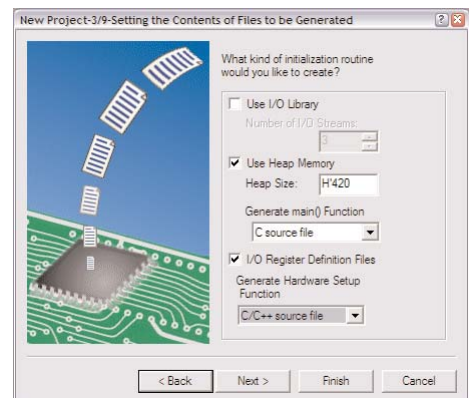

HEW Integrated Development Environment

Project Manager

- Graphical control of compiler/linker options
- Function browser
- Drag and drop code templates
- Built-in (or external) project make

Output Window

- Shows messages from build and find-in-files
- Linked to source in editor
- Version-control log

Built-in Editor

- Syntax-sensitive coloring
- Multiple files open at once
- Source-level debugging

Full Bus Trace

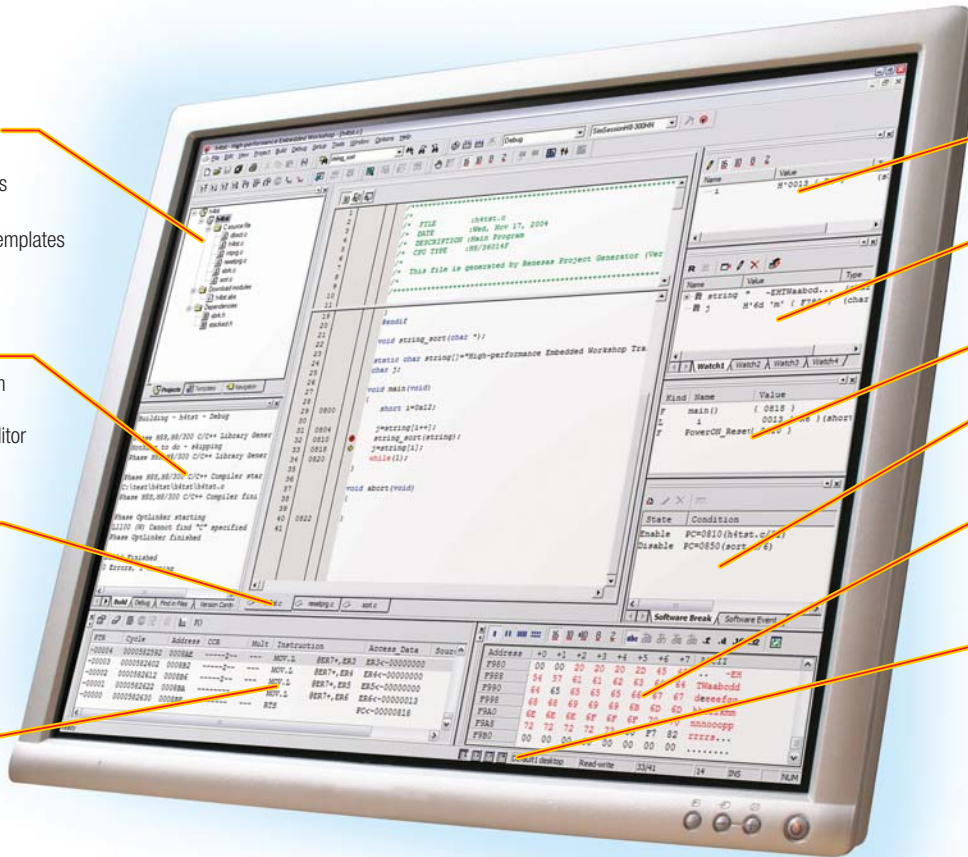

Local Variable Watch

C/C++ Variable Watch

Stack Trace

Complex Break Conditions

Memory View

- Highlights changed values

Virtual Desktop

- Allows multiple screen layouts to be recalled at the click of a button

New features to help optimize your application code

The integrated simulator/debugger has specific features and windows for testing the application code produced in the build process:

- Code profiling window (includes statistical and graphical displays)
- Performance analysis
- Code Coverage window
- Macro recorder and test case analysis

Additional analysis tools help you understand the operation and architecture of your embedded system application:

- Call Walker stack-trace analyzer
- Link Map file viewer

HEW Profile Tree and Chart views

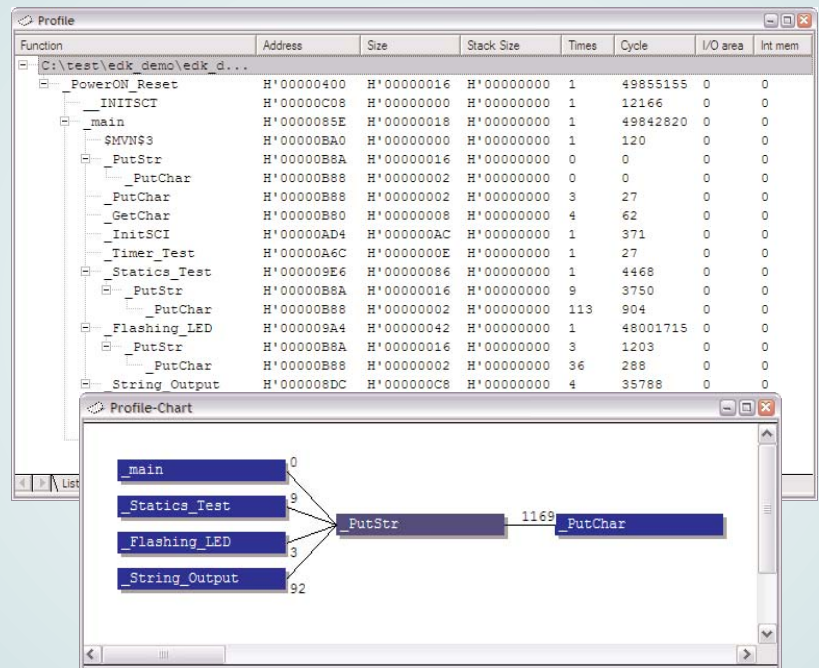

HEW Compiler Toolchain Options Dialogs

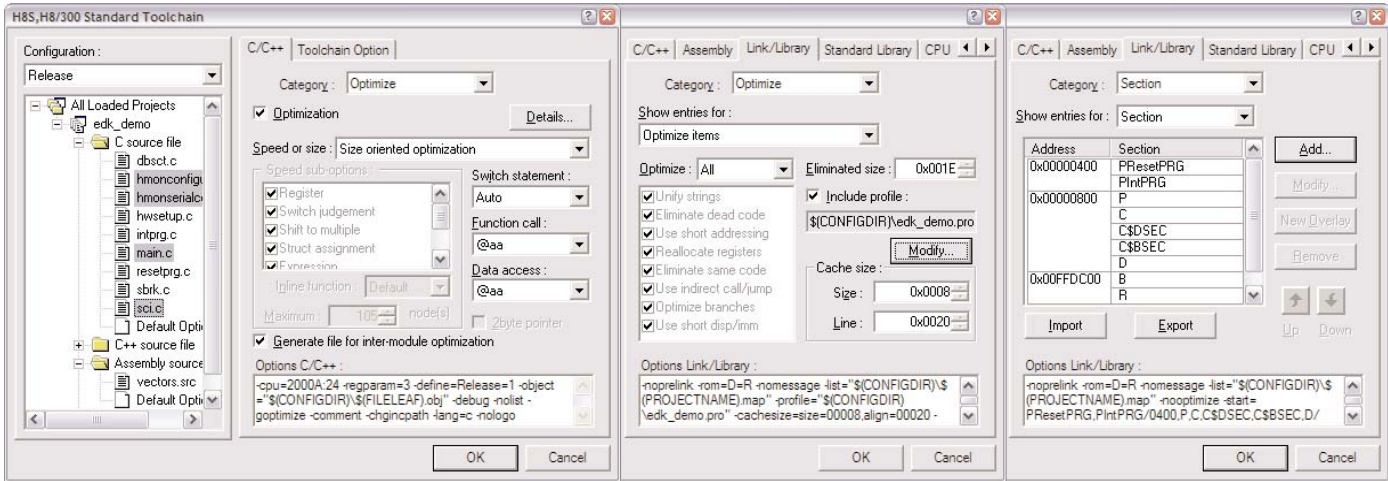

■ Software (continued)

Optimized C/C++ code generation toolchains

The Renesas compiler toolchains (compiler, assembler and linker) support the full C++ language specification and are backward compatible with C. They have extensions for complete embedded system control directly from C, without requiring the use of any assembler code. These extensions cover:

- Interrupt service routines
- Condition control register operations
- Sleep instruction
- Pseudo functions for instructions such as multiply-and-accumulate and decimal add and subtract
- Control of the optimized addressing and function call features of the device architecture and instruction set

The inter-module optimizing linker produces optimized software load modules by performing global optimizations on your application.

Free evaluation HEW download

The flexible licensing technology in Renesas' compiler toolchains means you can download a free evaluation copy of HEW with the compiler and generate unlimited code for 60 days. This is very useful for benchmarking optimization efficiency and architecture performance. After 60 days, code

size is limited to 64 Kbytes, which still allows you to evaluate the architecture or experiment with peripherals. For smaller devices, you can even complete a full application, since the evaluation version is identical to the full version with the exception of the code-size limits, including all optimization options.

Flash Development Toolkit

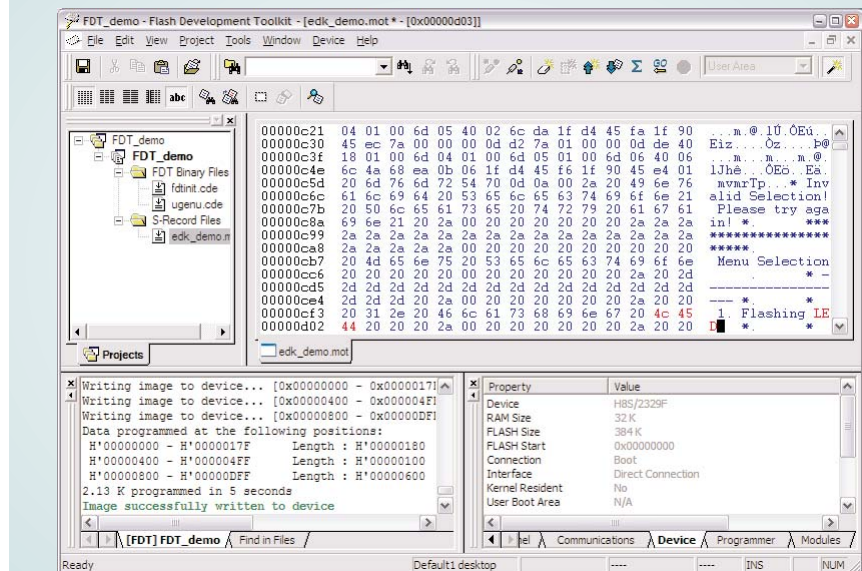

HEW Integrated Debugging

Modular debug target support is provided directly within the HEW environment so you can build your application and debug without leaving HEW. A debug session wizard allows you to easily add a new debug target to your workspace. Examples include:

- Instruction Simulator
- In-Circuit Emulators
 - E6000 series emulator
 - Compact emulator
- On-chip Emulators
 - E10A emulator
 - E8 emulator
- Evaluation boards using a ROM-resident monitor

Flash Development Toolkit

Renesas' Flash Development Toolkit (FDT) is an easy-to-use utility for programming your code into the on-chip flash memory of H8 MCUs. You can create workspaces to combine several s-record files into one download image and save connection settings to easily manage device programming.

FDT offers:

- Direct USB connection for USB boot mode devices
- Serial communication at up to 115,200 baud
- Hex image editor
- Extensive messaging that helps hardware development
- Support for programming via E8 USB debugger

Hardware

Evaluation and Development Kits

Renesas' low-cost Evaluation and Development Kits (EDKs) are inexpensive ways to experience the performance of H8 microcontrollers. Each kit comes complete with an EDK board and a CD-ROM that contains:

- An evaluation version of the High-performance Embedded Workshop (HEW), C/C++ compilers and a debug link to a resident monitor.
- The Flash Development Toolkit (FDT)

The CD included in the EDK also has a Quick-Start guide that shows how to install the software and contains full documentation with sample tutorials and a tutorial Project Generator plug-in for HEW.

H8 StarterKit Plus [SKP...] & Renesas Starter Kits [RSK...]

These kits bundle a low-cost target board with the E8 on-chip debug emulator and the evaluation version of the HEW IDE to offer an



integrated evaluation and development platform that lets you get up and running quickly with the H8 family. The E8 provides a foolproof connection to the host IDE and can also power the target board without the need for an external power supply.

E8 and E10A-USB on-chip emulators

The E8 and E10A-USB emulators are designed to connect with Renesas' H8 Tiny and JTAG



E10A-USB Emulator

■ Hardware (continued)

on-chip debugging interfaces, respectively. These low-cost tools provide real-time debugging on the target device, using the dedicated debugging resources built into the target microcontroller in your user hardware. The on-chip emulators connect to the target system via an interface that can be used both to debug the system and to program the MCU's on-chip flash memory.

The E8 and E10A-USB emulators use plug-and-play USB 2.0 compatible interfaces for easy connection to both notebook computers and desktop machines. These emulators offer:

- 255 PC breakpoints
- Hardware breakpoints on data and address
- Saved record of last 4 branches
- On-chip flash programming
- Integrated debugging support in HEW

Compact Emulators for H8 Tiny Series MCUs

For users who require full in-circuit emulation, but not the expanded resources of a traditional ICE, the compact emulator provides a superior cost-performance ratio in an extremely compact design. The emulator main unit comes in a significantly reduced size, compared with conventional emulator systems, allowing easier connection to target systems.

Although being affordable in price, it has all the basic functions needed for real development, such as access to all of the devices, pins and

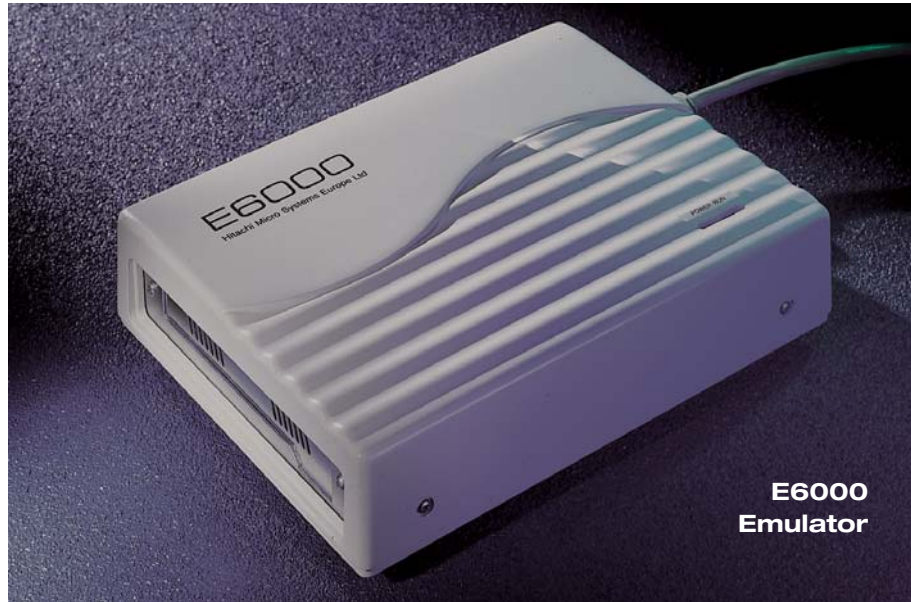

**E6000
Emulator**

memory map as well as real-time trace and hardware breaks.

- Includes HEW integrated development and debugging environment and evaluation copy of C/C++ compiler tools.
- Supplied as a package including the target cable and PCB adaptor.

E6000/E6000H in-circuit emulators

Renesas' E6000 series comprises a range of advanced real-time in-circuit emulators, each of which supports a family of processors. You can use the emulators as totally self-contained solutions for software development and debugging, or connect them via a custom cable to a target system for debugging your hardware. These powerful debugging tools provide:

- Zero wait-state, non-intrusive real-time emulation (E6000 < 33MHz, E6000H < 66MHz)
- Emulation memory from 1MB to 4MB, which can be mapped into the target processor's address space

- 256 PC breakpoints
- Trace Buffer of up to 32K cycles, which can be stopped and read during program execution
- Trace buffer acquisition filtering using the Complex Event System
- Post-acquisition trace filtering and search facility
- Automatic tracking of the target system supply voltage to ensure that the emulator draws no power
- Multiple target clock selection
- Integrated debugging support in HEW

E6000 Complex Event System

The debugging power of the E6000 comes from the Complex Event System (CES), a sophisticated mechanism that lets you specify exactly the set of conditions you want to examine. Break, trace or timing functions are activated using Event and Range channels. You control the CES from the HEW environment.

Specify exact conditions for an Event

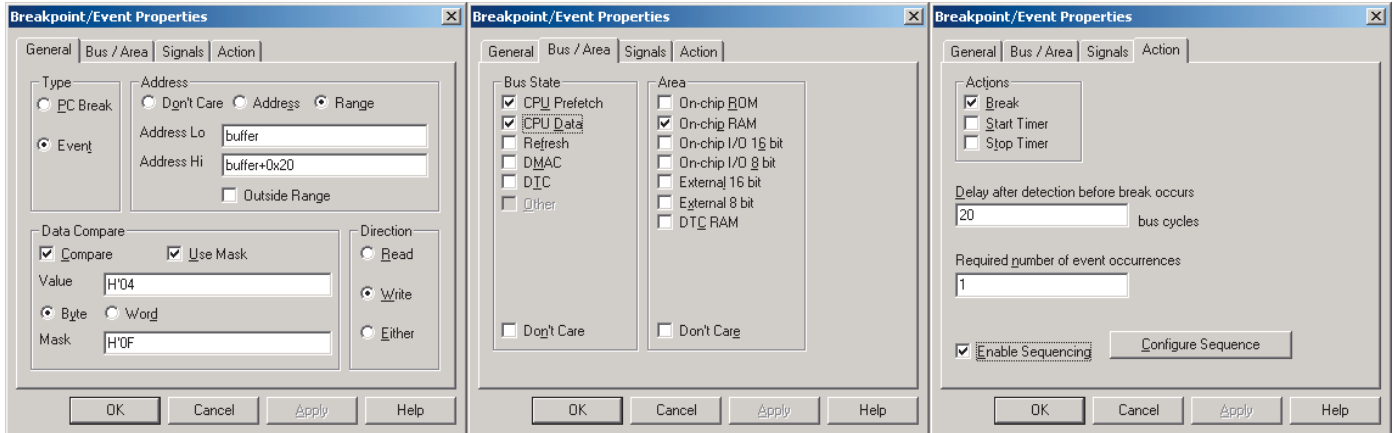

Complex Event System (CES) Event Block

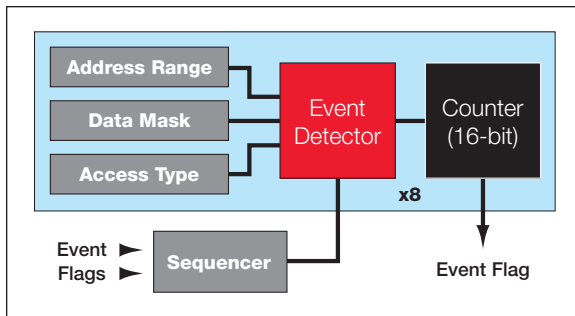

Combine Events logically and sequentially for precise control

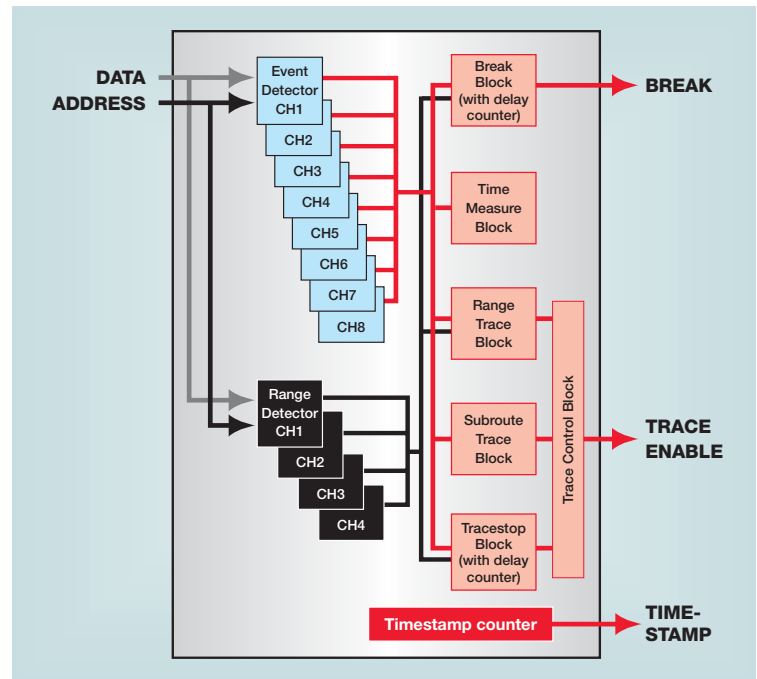

The Complex Event System offers:

- Up to 12 hardware breakpoints using the Event and Range channels
- Execution time measurement of total time or relative time, with a resolution of 20ns to 16µs
- Four user logic probes that can be used as CES trigger events and trace data

Events may be combined to define a complex sequence of conditions/actions. An event sequence defines a list of events, where each event may be activated or deactivated by the occurrence of another. Up to eight events can be sequenced to generate an action. The event sequencer gives you such flexible control over the CES that practically any development problem can be trapped and investigated.

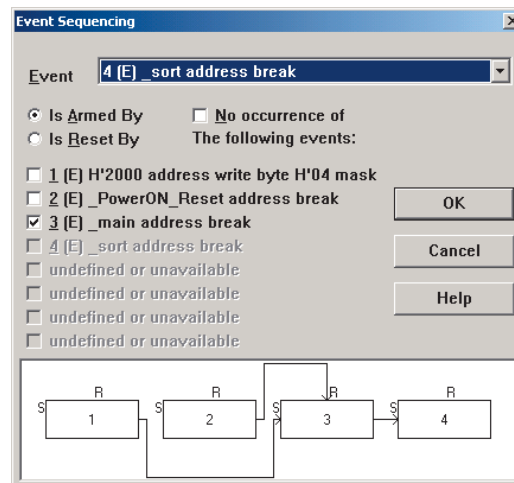

Event Sequencing dialog gives a graphical view of Complex Event System logic

In-Circuit Emulator Selection

Choosing the components required to complete a full emulation system for a device can be a complicated task, due to specific device support and package variations. The Renesas website provides a useful tool to aid in selecting the required components.

Easy Instructions:

1

Go to the Renesas web site and browse to an emulator product page.

2

Click on the **Options** link in the navigation menu to open the selection search.

3

Select the emulator type in the “Tool Name” menu and then the required Family, Series and Group. Click “Display Results” for a list of the required components.

The screenshot shows the Renesas website's 'In-circuit Emulators (HW)' page for the E6000. A navigation menu on the left includes 'Options' with a red arrow pointing to it. The main content area features a search tool with a 'Tool Name' dropdown set to 'E6000'. Below this are dropdowns for 'Family' (H8S Family), 'Series' (H8S/2300 Series), and 'Group' (H8S/2329 Group). A 'Display results' button is visible. A note below the search tool reads: 'note: Search for options to E6000. Please select a device and click "Display results". For details, see at the following the Accessory Guide. <http://tool-support.renesas.com/eng/accessories/index.html>'.

The search results are organized into sections: 'H8S Family', 'H8S/2329 Group', and 'H8S/2300 Series H8S/2329 Group FP-128'. The 'Recommended products' table for the H8S/2300 Series H8S/2329 Group FP-128 is as follows:

	Product name	Mass produced	Under development	Discontinued	Option Included	Note
Emulator Type Number	HS2339EP61H	x				
Memory Board	HS6000EMS12H	x			x	4MB Expanded Memory
User interface cable or User interface board	HS2328ECH61H	x				
IC socket (connect to target system)	NOPACK128RD	x			x	Tokyo Eletech Co., Ltd. (One socket is attached to the user interface board or user interface cable product.)
Host System Interface (at least one interface board)	HS6000EIP02H	x				PCMCIA Interface HS6000EIP01H has shifted to HS6000EIP02H.
	HS6000EIC02H	x				PCI Interface
	HS6000ELN01H	x				LAN Interface
	HS6000EIU02H	x				USB Interface

The 'Recommended products' table for the H8S/2300 Series H8S/2329 Group PTQP0120LA-A *Previous code : TFP-120 is as follows:

	Product name	Mass produced	Under development	Discontinued	Option Included	Note
Emulator Type Number	HS2339EP61H	x				
Memory Board	HS6000EMS12H	x			x	4MB Expanded Memory
User interface cable or User interface board	HS2328ECN61H	x				
IC socket (connect to target system)	IC149-120-043-B51	x			x	Yamaichi Electronics Co., Ltd. (One socket is attached to the user interface board or user interface cable

H8 Family Development Tool Selector

Series	Group	Catalog Part Number	Renesas Package Code	Starter Kit	On-chip Debug Emulator	Compact Emulator	Full Emulator			IDE (C Compiler)*
						Compact Emulator (including PCB Adaptor)	Base Unit including PC Interface	Personality Kit (Pod/Probe)	PCB Adaptor (Target Cable)	
SLP	H8/38602R	HD64F38602RFT4V	PVQN0032KA-A	SKP38602	R0E000080KCE00	-	-	-	-	RTA-HEWH8-1U
	H8/38004	HD64F38004H4V	PRQP0064GB-A	SKP38024	R0E000080KCE00	-	HS38000EPI61H	HS3800EBK61H	HS3802ECH61H	RTA-HEWH8-1U
	H8/38024	HD64F38024RHV	PRQP0080JB-A	SKP38024	R0E000080KCE00	-	HS38000EPI61H	HS3800EBK61H	HS38024ECH61H	RTA-HEWH8-1U
	H8/3827	HD64F38324HV	PRQP0080JB-A	R0K438347S000BE	R0E000080KCE00	-	HS38000EPI61H	HS388REBK61H	HS3864ECH61H	RTA-HEWH8-1U
	H8/3827	HD64F38327HV	PRQP0080JB-A	R0K438347S000BE	R0E000080KCE00	-	HS38000EPI61H	HS388REBK61H	HS3864ECH61H	RTA-HEWH8-1U
	H8/3847	HD64F38344HV	PRQP100KA-A	R0K438347S000BE	R0E000080KCE00	-	HS38000EPI61H	HS388REBK61H	HS3887ECH61H	RTA-HEWH8-1U
	H8/3847	HD64F38347HV	PRQP100KA-A	R0K438347S000BE	R0E000080KCE00	-	HS38000EPI61H	HS388REBK61H	HS3887ECH61H	RTA-HEWH8-1U
	H8/38076R	HD64F38076RH4V	PRQP0080JB-A	3DK38076	R0E000080KCE00	-	-	-	-	RTA-HEWH8-1U
H8/38086R	HD64F38086RH4V	PRQP0080JB-A	3DK38086R	R0E000080KCE00	-	-	-	-	RTA-HEWH8-1U	
H8/Tiny	H8/36912	HD64F36912GFHV	PLQP0032GC-A	SKP36912	R0E000080KCE00	-	HS3664EPI62H	-	HS36902ECH61H	RTA-HEWH8-1U
	H8/36014	HD64F36012GFPV	PLQP0064KC-A	SKPH8TINY	R0E000080KCE00	R0E436640CPE20	HS3664EPI62H	-	HS36014ECH61H	RTA-HEWH8-1U
	H8/36014	HD64F36014GFPV	PLQP0064KC-A	SKPH8TINY	R0E000080KCE00	R0E436640CPE20	HS3664EPI62H	-	HS36014ECH61H	RTA-HEWH8-1U
	H8/36064	HD64F36064GHV	PRQP0064GB-A	SKPH8TINY	R0E000080KCE00	R0E436640CPE10	HS3664EPI62H	-	HS3687ECH62H	RTA-HEWH8-1U
	H8/36094	HD64F36094XXX	PVQN0048KA-A	SKPH8TINY	R0E000080KCE00	-	HS3664EPI62H	-	HS36014ECN61H	RTA-HEWH8-1U
	H8/36077	HD64F36074GHV	PRQP0064GB-A	EDK3687	R0E000080KCE00	-	HS3664EPI62H	-	HS3687ECH62H	RTA-HEWH8-1U
	H8/36077	HD64F36077GHV	PRQP0064GB-A	EDK3687	R0E000080KCE00	-	HS3664EPI62H	-	HS3687ECH62H	RTA-HEWH8-1U
	H8/36087	HD64F36087FPV	PLQP0064KC-A	EDK3687	R0E000080KCE00	R0E436640CPE20	HS3664EPI62H	-	HS3687ECH61H	RTA-HEWH8-1U
	H8/36049	HD64F36049GHV	PRQP0080JB-A	EDK3687	R0E000080KCE00	R0E436049CPE10	HS3664EPI62H	HS36024EIO61H	HS36049ECH61H	RTA-HEWH8-1U
H8S	H8S/2168	HD64F2168VTE33V	PTQP0144LC-A	3DK2166	HS0005KCU01H	-	HS6000EIOU2H	HS2168EPI61H	HS2168ECN61H	RTA-HEWH8-1U
	H8S/2168	HD64F2167VTE33V	PTQP0144LC-A	3DK2166	HS0005KCU01H	-	HS6000EIOU2H	HS2168EPI61H	HS2168ECN61H	RTA-HEWH8-1U
	H8S/2168	HD64F2166VTE33V	PTQP0144LC-A	3DK2166	HS0005KCU01H	-	HS6000EIOU2H	HS2168EPI61H	HS2168ECN61H	RTA-HEWH8-1U
	H8S/2212	HD64F2211UFP24V	PLQP0064KC-A	3DK2218	HS0005KCU01H	-	HS2214EPI62H-U	-	HS2212ECH61H	RTA-HEWH8-1U
	H8S/2212	HD64F2212UFP24V	PLQP0064KC-A	3DK2218	HS0005KCU01H	-	HS2214EPI62H-U	-	HS2212ECH61H	RTA-HEWH8-1U
	H8S/2218	HD64F2218UTF24V	PTQP0100LC-A	3DK2218	HS0005KCU01H	-	HS2214EPI62H-U	HS6000EMS12H	HS2218ECN61H	RTA-HEWH8-1U
	H8S/2215	HD64F2215UTE16V	PTQP0120LA-A	EDK2215	-	-	HS2214EPI62H-U	HS6000EMS12H	HS2215RECN61H	RTA-HEWH8-1U
	H8S/2215	HD64F2215RUTE24V	PTQP0120LA-A	R0K42215RS000BE	HS0005KCU01H	-	HS2214EPI62H-U	HS6000EMS12H	HS2215RECN61H	RTA-HEWH8-1U
	H8S/2238R	HD64F2238RF A6V	PRQP100KA-A	EDK2239	-	-	E62633R	-	EBH2238Q100B	RTA-HEWH8-1U
	H8S/2239	HD64F2239FA20V	PRQP100KA-A	EDK2239	-	-	HS2214EPI62H-U	HS6000EMS12H	HS2238ECH61H	RTA-HEWH8-1U
	H8S/2317BL	HD64F2317VTEBL25V	PTQP0100KA-A	EDK2329	HS0005KCU01H	-	E62339	-	EBH2318Q100B	RTA-HEWH8-1U
	H8S/2319	HD64F2318VTE25V	PTQP100KA-A	EDK2329	HS0005KCU01H	-	E62339	-	EBH2318Q100B	RTA-HEWH8-1U
	H8S/2327BL	HD64F2327BVFBL25V	PRQP0128KB-A	EDK2329	HS0005KCU01H	-	E62339	-	EBH2328Q128	RTA-HEWH8-1U
	H8S/2368	HD64F2367VTE33V	PTQP0120LA-A	EDK2378	HS0005KCU01H	-	E62678R	-	EBH2678RQ144	RTA-HEWH8-1U
	H8S/2368	HD64F2368VTE34V	PTQP0120LA-A	EDK2378	HS0005KCU01H	-	E62678R	-	EBH2678RQ144	RTA-HEWH8-1U
	H8S/2378R	HD64F2378R V FQ34V	PLQP0144KC-A	EDK2378	HS0005KCU01H	-	E62678R	-	EBH2678RQ144	RTA-HEWH8-1U
H8S/2633	HD64F2633RF28V	PRQP0128KB-A	EDK2638	-	-	E62633R	-	EBH2633Q128	RTA-HEWH8-1U	
H8SX	H8SX/1653	R5F61653N50FTV	PTQP0120LA-A	R0K561664S000BE	HS0005KCU01H	-	HS6000EIOU2H	HS1650EPH60H	HS1653ECN61H	RTA-HEWH8-1U

For more information on tool accessories or different packages, please go to Renesas' tools website.

* Multi-user and floating network licenses available; see website for details.

Third-party Development Tools

Many third-party experts offer hardware and software development tools supported by design services, RTOS, compilers, board-level solutions, custom firmware, and board-support packages (BSPs) to meet the needs of customers developing H8-based products.

IAR Systems offers a consistent IDE that supports nearly all MCU targets in the industry. The environment includes MISRA C support with integrated CSpy debugging, E8 and E10A-USB support and Elf/Dwarf debug output (compatible with HEW for debugging with full ICE). In addition, IAR offers RTOS-aware debugging

with plug-ins for Micrium μ C/OS-II, OSEK (ORTI) and Segger embOS. www.iar.com

Segger Microcontroller Systems provides a small and efficient real-time kernel embOS with graphical GUI and file system libraries. www.segger.com

KPIT Cummins Infosystems provides free-of-charge maintenance and support for GNU compiler tools, including installers that integrate the GCC toolchain into the HEW IDE and allow use with Renesas debuggers and emulators. www.kpitgnutools.com

For more details about 3rd party support, please visit: <http://america.renesas.com/toolspartners>



H8 Super Low Power Series Line-up

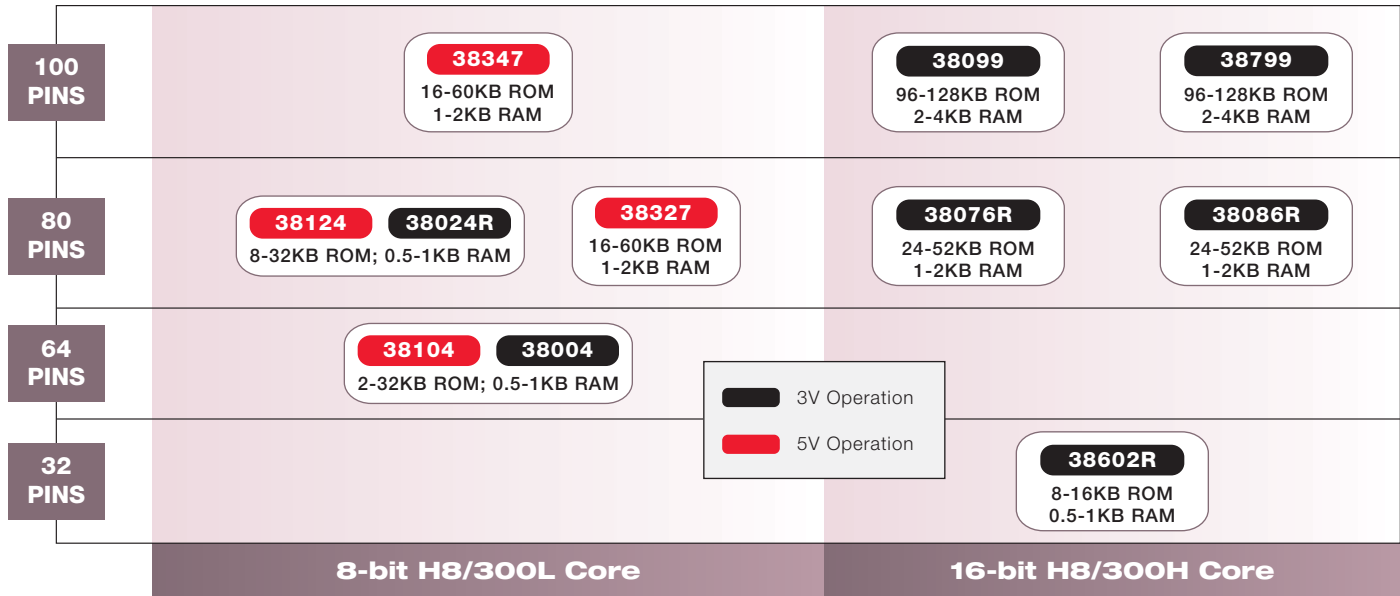

■ Features

- Multiple techniques minimize power consumption and extend battery life
 - Low-power CMOS technology for 1.8V operation
 - Up to 9 Low-power modes
 - 32 kHz on-chip sub-clock oscillator
 - Peripheral-independent standby mode
- Advanced analog interfaces such as 14-bit Delta-Sigma converter
- Shorter oscillation stabilization time lets applications wake up faster from standby mode, conserving power
- LCD controller with built-in voltage booster circuit eliminates need for external DC/DC converter
- High current port for driving LEDs directly
- 16-bit asynchronous counter (AEC) operates even when device is in standby mode
- Low cost development tools using on-chip debug

■ Applications

Metering: Electric, gas and water meters

Medical: Glucose meters, heart-rate monitors, thermometers, weight scales

Security: Intrusion detection systems, smoke detectors, fire alarms

Consumer: Refrigerators, washer/dryers, remote controllers, dehumidifiers, thermostats, lawn sprinkler timers

Computing: Remotely updatable displays, remote actuators

Typical Power Consumption (@ 1.8V, 25°C)



H8/38086R Block Diagram

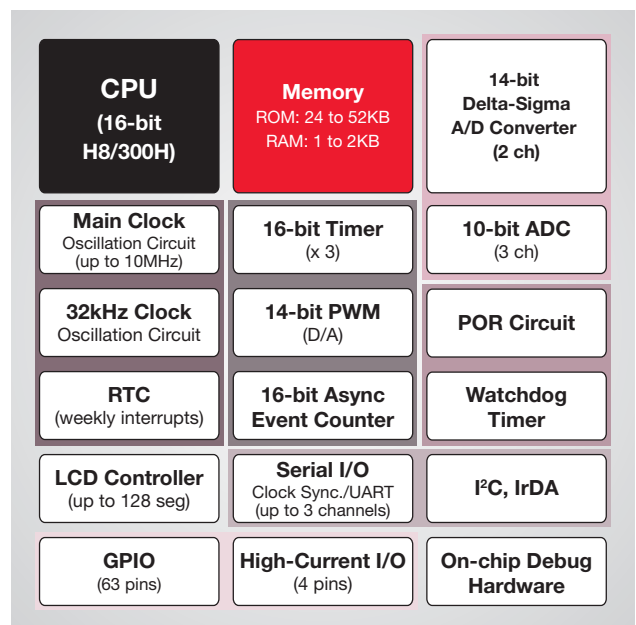

H8 Super Low Power Series Selector Guide

Group	Catalog Part Number	Flash (Kbytes)	Mask ROM Option (Kbytes) (See Note 1)	RAM (Kbytes)	Vcc Min	Vcc Max	Max Input MHz @ Vcc Max	32 kHz Sub Clock (See Note 6)	Power Down Modes	Timers				Serial I/F (Sync/Async)	LCD Controller	A/D 10-bit Resolution	GPIO [See Note 2] (High Current) (See Note 3)	Extended Temperature (See Note 4)	Special Features	Package Code: Part No. Suffix (See Note 5)														
										8-bit Timers	16-bit Timers	Watchdog Timers	14-bit PWM Serial I/F (Sync/Async)							PLQP0064KC-A : FP	PLQP0100KB-A : F	PRQP0064GB-A : H	PRQP0080GB : F	PRQP0080JB-A : H	PRQP0100KA-A : H	PTLG0085JA-A : LPV	PTLG0113JA-A : LGV	PTQP0080KC-A : W	PTQP0100KA-A : X	PTQP0100LC-A : X	PVQN0032KA-A : FT			
8-bit H8/300L Core	H8/38327	HD64F38324	32	16-60	2	2.7	5.5	16	Y	8	3	1	1	1	2	32x4	8	64 (8)	Y	16-bit AEC	-	-	-	-	Y	-	-	-	-	Y	-	-	-	-
		HD64F38327	60		2	2.7	5.5	16	Y	8	3	1	1	1	2	32x4	8	64 (8)	Y	16-bit AEC	-	-	-	-	Y	-	-	-	-	Y	-	-	-	
	H8/38347	HD64F38344	32	16-60	2	2.7	5.5	16	Y	8	3	1	1	1	2	40x4	12	84 (16)	Y	16-bit AEC	-	-	-	-	Y	-	-	-	Y	-	Y	-	-	
		HD64F38347	60		2	2.7	5.5	16	Y	8	3	1	1	1	3	40x4	12	84 (16)	Y	16-bit AEC	-	-	-	-	Y	-	-	-	Y	-	Y	-	-	
	H8/38004	HD64F38002FP10	16	8-32	1	2.7	3.6	10	Y	7	1	1	1	-	1	4	50 (6)	Y	16-bit AEC, 2-ch 10-bit PWM	Y	-	-	-	-	-	-	-	-	-	-	-	-		
		HD64F38002FP4	16		1	2.2	3.6	4	Y	7	1	1	1	-	1	4	50 (6)	-		Y	-	-	-	-	-	-	-	-	-	-	-	-	-	
		HD64F38002H10	16		1	2.7	3.6	10	Y	7	1	1	1	-	1	4	50 (6)	Y		-	Y	-	-	-	-	-	-	-	-	-	-	-	-	
		HD64F38002H4	16		1	2.2	3.6	4	Y	7	1	1	1	-	1	4	50 (6)	-		-	Y	-	-	-	-	-	-	-	-	-	-	-	-	
		HD64F38004FP10	32		1	2.7	3.6	10	Y	7	1	1	1	-	1	25x4	4	50 (6)		Y	Y	-	-	-	-	-	-	-	-	-	-	-	-	-
		HD64F38004FP4	32		1	2.2	3.6	4	Y	7	1	1	1	-	1	25x4	4	50 (6)		-	Y	-	-	-	-	-	-	-	-	-	-	-	-	-
		HD64F38004H10	32		1	2.7	3.6	10	Y	7	1	1	1	-	1	25x4	4	50 (6)		Y	-	Y	-	-	-	-	-	-	-	-	-	-	-	-
HD64F38004H4	32	1	2.2	3.6	4	Y	7	1	1	1	-	1	25x4	4	50 (6)	-	-	Y	-	-	-	-	-	-	-	-	-	-	-	-				
H8/38104	HD64F38102	16	8-32	1	2.7	5.5	20	Y	7	1	1	1	-	1	25x4	4	49 (12)	Y	16-bit AEC, 2-ch 10-bit PWM, POR, LVD	Y	Y	-	-	-	-	-	-	-	-	-	-	-	-	
	HD64F38104	32		1	2.7	5.5	20	Y	7	1	1	1	-	1	25x4	4	49 (12)	Y	16-bit AEC, 2-ch 10-bit PWM, POR, LVD	Y	Y	-	-	-	-	-	-	-	-	-	-	-	-	-
H8/38024R	HD64F38024R	32	8-32	1	2.7	3.6	10	Y	8	3	1	1	-	1	32x4	8	66 (6)	Y	16-bit AEC, 2-ch 10-bit PWM	-	-	-	Y	Y	-	Y	-	Y	-	Y	-	-	-	
H8/38124	HD64F38122	16	8-32	1	2.7	5.5	20	Y	8	3	1	1	-	1	32x4	8	65 (14)	Y	16-bit AEC, 2-ch 10-bit PWM, POR, LVD	-	-	-	-	Y	-	-	-	Y	-	-	-	-		
	HD64F38124	32		1	2.7	5.5	20	Y	8	3	1	1	-	1	32x4	8	65 (14)	Y	16-bit AEC, 2-ch 10-bit PWM, POR, LVD	-	-	-	-	Y	-	-	-	Y	-	-	-	-		
H8/38076R	HD64F38076RH10	52	24-48	2	2.7	3.6	10	Y	7	-	3	1	2	3	32x4	8	63 (4)	Y	RTC, 16-bit AEC, IrDA, I ² C, POR	-	-	-	Y	-	-	-	-	-	-	-	-			
	HD64F38076RH4	52		2	1.8	3.6	4	Y	7	-	3	1	2	3		8	63 (4)	Y		-	-	-	Y	-	-	-	-	-	-	-	-	-		
	HD64F38076RLP10	52		2	2.7	3.6	10	Y	7	-	3	1	2	3		8	63 (4)	Y		-	-	-	-	Y	-	-	-	-	-	-	-	-		
	HD64F38076RPL4	52		2	1.8	3.6	4	Y	7	-	3	1	2	3		8	63 (4)	Y		-	-	-	-	Y	-	-	-	-	-	-	-	-		
	HD64F38076RW10	52		2	2.7	3.6	10	Y	7	-	3	1	2	3		8	63 (4)	Y		-	-	-	-	-	Y	-	-	-	-	-	-	-		
	HD64F38076RW4	52		2	1.8	3.6	4	Y	7	-	3	1	2	3		8	63 (4)	Y		-	-	-	-	-	Y	-	-	-	-	-	-	-		
H8/38086R	HD64F38086RH10	52	24-48	2	2.7	3.6	10	Y	7	-	3	1	2	3	32x4	3	63 (4)	Y	RTC, 16-bit AEC, IrDA, 2-ch 14-bit ΔΣ ADC, I ² C, POR	-	-	-	Y	-	-	-	-	-	-	-	-			
	HD64F38086RH4	52		2	1.8	3.6	4	Y	7	-	3	1	2	3		3	63 (4)	-		-	-	-	Y	-	-	-	-	-	-	-	-			
	HD64F38086RPL10	52		2	2.7	3.6	10	Y	7	-	3	1	2	3		3	63 (4)	Y		-	-	-	-	Y	-	-	-	-	-	-	-			
	HD64F38086RPL4	52		2	1.8	3.6	4	Y	7	-	3	1	2	3		3	63 (4)	-		-	-	-	-	Y	-	-	-	-	-	-	-			
	HD64F38086RW10	52		2	2.7	3.6	10	Y	7	-	3	1	2	3		3	63 (4)	Y		-	-	-	-	-	Y	-	-	-	-	-	-	-		
	HD64F38086RW4	52		2	1.8	3.6	4	Y	7	-	3	1	2	3		3	63 (4)	-		-	-	-	-	-	Y	-	-	-	-	-	-	-		
H8/38099	HD64F38099FP4	128	96-128	4	1.8	3.6	4	Y	7	2	3	1	4	4	40x4	8	83 (4)	Y	RTC, 16-bit AEC, IrDA, I ² C, POR	-	Y	-	-	-	-	-	-	-	-	-	-			
	HD64F38099FP10	128		4	2.7	3.6	10	Y	7	2	3	1	4	4		8	83 (4)	Y		-	Y	-	-	-	-	-	-	-	-	-	-	-		
	HD64F38099LG4V	128		4	1.8	3.6	4	Y	7	2	3	1	4	4		8	83 (4)	Y		-	-	-	-	-	Y	-	-	-	-	-	-	-		
	HD64F38099LG10V	128		4	2.7	3.6	10	Y	7	2	3	1	4	4		8	83 (4)	Y		-	-	-	-	-	-	Y	-	-	-	-	-	-		
H8/38799	HD64F38799FP4	128	96-128	4	1.8	3.6	4	Y	7	2	3	1	4	4	-	8	83 (4)	Y	RTC, 16-bit AEC, IrDA, I ² C, POR	-	Y	-	-	-	-	-	-	-	-	-	-			
	HD64F38799FP10	128		4	2.7	3.6	10	Y	7	2	3	1	4	4		8	83 (4)	Y		-	Y	-	-	-	-	-	-	-	-	-	-	-		
	HD64F38799LG4V	128		4	1.8	3.6	4	Y	7	2	3	1	4	4		8	83 (4)	Y		-	-	-	-	-	Y	-	-	-	-	-	-	-		
	HD64F38799LG10V	128		4	2.7	3.6	10	Y	7	2	3	1	4	4		8	83 (4)	Y		-	-	-	-	-	-	Y	-	-	-	-	-	-		
H8/38602R	HD64F38602RFT10	16	8-16	1	2.7	3.6	10	Y	7	1	1	1	-	1	-	6	19 (3)	Y	RTC, 16-bit AEC, IrDA, I ² C, 2-ch comparator, SSU, POR	-	-	-	-	-	-	-	-	-	-	-	-	Y		
	HD64F38602RFT4	16		1	1.8	3.6	4	Y	7	1	1	1	-	1	-	6	19 (3)	Y	RTC, 16-bit AEC, IrDA, I ² C, 2-ch comparator, SSU, POR	-	-	-	-	-	-	-	-	-	-	-	Y			

Notes:

1. Please refer to the Hardware Manual for the operating voltage of Mask ROM devices.
2. This is the sum of the I/O pins + input-only + output-only.
3. High-current is defined as greater than or equal to 10mA for a signal being driven low. This pin count is included in the GPIO total.
4. Please visit Renesas website for full part number, specification, and availability of extended temperature parts.
5. Full part number includes **Package Suffix** for desired package. Refer to Appendix C for more details on part numbering.
6. Y = Yes, includes 32kHz crystal oscillator circuitry.

H8 Tiny Series Line-up

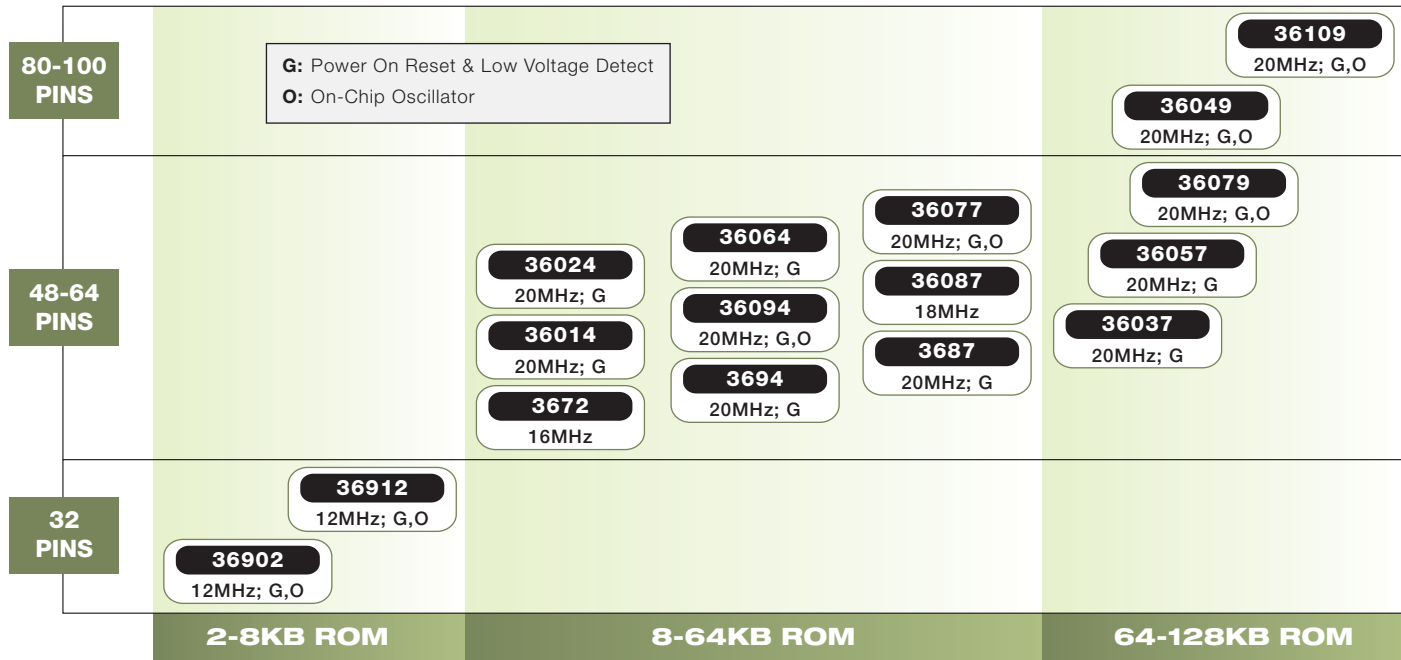

■ Features

- High performance 16-bit CPU, with eight 32-bit general-purpose registers and 32-bit data processing
- Up to 20MHz operation
- On-chip flash for simplified production programming or code update
- Flexible clocking scheme with multiple clock sources and multiple levels of clock dividers
- Various 8- and 16-bit timers for advanced waveform generations typically used in motor control applications
- Multiple fail-safe features such as watchdog timers with dedicated on-chip oscillator, external oscillator fail detection, low-voltage detection and Reset source detection
- High current port for driving LEDs directly
- High peripheral integration, including real-time clock, up to sixteen A/D channels and a range of communication interfaces
- System cost reduction with built-in power-on reset circuitry, band-gap voltage regulators and on-chip oscillators
- Low-cost development tools using on-chip debug
- Code and peripheral function compatibility with other H8 microcontroller families

■ Applications

- Consumer:** White goods (refrigerators, washer/dryers, cooking ranges, etc.), home electronics, game pads, vacuum cleaners
- Industrial:** HVAC systems, thermostats, controllers for small DC brushless motors, stepper motors
- Office Automation:** Mechanical controls for fax, printers, measurement devices

36077, 36079 Block Diagram

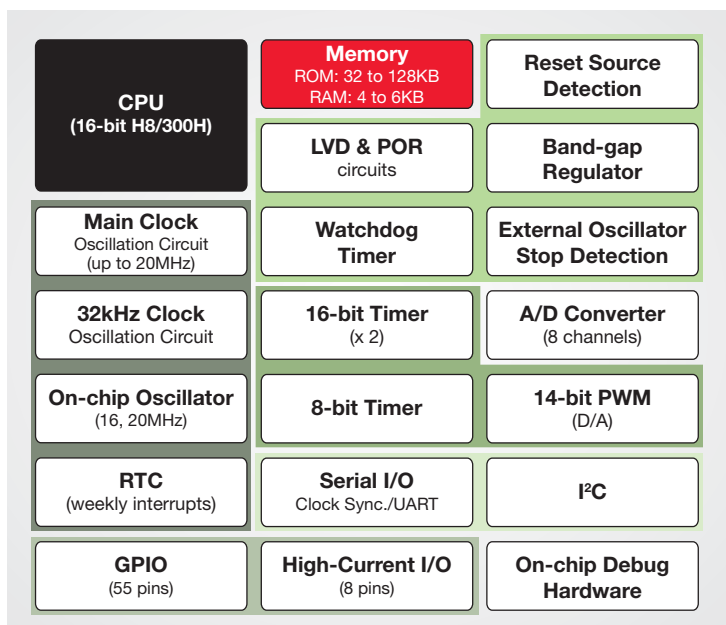

H8 Tiny Series Selector Guide

Group	Catalog Part Number	Flash (Kbytes)	Mask ROM Options (Kbytes) (See Note 1)	RAM (Kbytes)	Vcc Min	Vcc Max	Max MHz @ Vcc Max	32 kHz Sub Clock (See Note 6)	Timers				Serial I/F			A/D 10-bit Resolution POR and LVD On-chip Debug	GPIO (See Note 2) (High current) [See Note 3] Extended Temperature (See Note 4)	Special Features	Package Code : Part No. Suffix (See Note 5)																
									8-bit Timers	16-bit Timers	Watchdog Timers	14-bit PWM D/A	Serial (Sync/Async) SSU (SPI Compatible)	I ² C	PLQP0032GC-A : FH PLQP0048JA-A : FX PLQP0048KC-A : FY PLQP0064KB-A : FZ PLQP0064KC-A : FP PLQP0100KB-A : F PRD0032BB-A : P PRQP0064GB-A : H PRQP0080JB-A : H PRQP0100JE-B : F PRSP0032DC-A : TP PVQND048KA-A : FT																				
H8/3672	HD64F3670	8	-	2	3.0	5.5	16	-	1	1	1	-	1	-	-	4	-	Y	30 (5)	Y	-	-	-	-	-	-	-	-	-	-	-	-	-		
	HD64F3672	16	-	2	3.0	5.5	16	-	1	1	1	-	1	-	-	4	-	Y	30 (5)	Y	-	-	-	-	-	-	-	-	-	-	-	-			
H8/3687	HD64F3684	32	-	4	3.0	5.5	20	Y	2	2	1	1	2	-	1	8	-	Y	53 (8)	Y	-	-	-	-	-	-	-	-	-	-	-	-	-		
	HD64F3684G	32	16-56	4	3.0	5.5	20	Y	2	2	1	1	2	-	1	8	Y	Y	53 (8)	Y	-	-	-	-	-	-	-	-	-	-	-	-	-		
	HD64F3687	56	-	4	3.0	5.5	20	Y	2	2	1	1	2	-	1	8	-	Y	53 (8)	Y	-	-	-	-	-	-	-	-	-	-	-	-	-	-	
	HD64F3687G	56	-	4	3.0	5.5	20	Y	2	2	1	1	2	-	1	8	Y	Y	53 (8)	Y	-	-	-	-	-	-	-	-	-	-	-	-	-	-	
H8/3694	HD64F3694	32	-	2	3.0	5.5	20	Y	2	1	1	-	1	-	1	8	-	Y	37 (8)	Y	-	-	-	-	-	-	-	-	-	-	-	-	-	-	
	HD64F3694G	32	8-32	2	3.0	5.5	20	Y	2	1	1	-	1	-	1	8	Y	Y	37 (8)	Y	-	-	-	-	-	-	-	-	-	-	-	-	-	-	
H8/36014	HD64F36012	16	-	2	3.0	5.5	20	-	1	1	1	-	2	-	-	4	-	Y	34 (5)	Y	-	-	-	-	-	-	-	-	-	-	-	-	-	-	
	HD64F36012G	16	8-32	2	3.0	5.5	20	-	1	1	1	-	2	-	-	4	Y	Y	34 (5)	Y	-	-	-	-	-	-	-	-	-	-	-	-	-	-	
	HD64F36014	32	-	2	3.0	5.5	20	-	1	1	1	-	2	-	-	4	-	Y	34 (5)	Y	-	-	-	-	-	-	-	-	-	-	-	-	-	-	
	HD64F36014G	32	-	2	3.0	5.5	20	-	1	1	1	-	2	-	-	4	Y	Y	34 (5)	Y	-	-	-	-	-	-	-	-	-	-	-	-	-	-	
H8/36024	HD64F36022	16	-	2	3.0	5.5	20	-	1	1	1	-	3	-	-	4	-	Y	34 (5)	Y	-	-	-	-	-	-	-	-	-	-	-	-	-	-	
	HD64F36022G	16	16-32	2	3.0	5.5	20	-	1	1	1	-	3	-	-	4	Y	Y	34 (5)	Y	-	-	-	-	-	-	-	-	-	-	-	-	-	-	
	HD64F36024	32	-	2	3.0	5.5	20	-	1	1	1	-	3	-	-	4	-	Y	34 (5)	Y	-	-	-	-	-	-	-	-	-	-	-	-	-	-	
	HD64F36024G	32	-	2	3.0	5.5	20	-	1	1	1	-	3	-	-	4	Y	Y	34 (5)	Y	-	-	-	-	-	-	-	-	-	-	-	-	-	-	
H8/36037	HD64F36034	32	-	2	3.0	5.5	20	-	2	2	1	-	1	1	-	8	-	Y	53 (8)	Y	-	-	-	-	-	-	-	-	-	-	-	-	-	-	
	HD64F36034G	32	16-56	2	3.0	5.5	20	-	2	2	1	-	1	1	-	8	Y	Y	53 (8)	Y	-	-	-	-	-	-	-	-	-	-	-	-	-	-	
	HD64F36037	56	-	3	3.0	5.5	20	-	2	2	1	-	1	1	-	8	-	Y	53 (8)	Y	-	-	-	-	-	-	-	-	-	-	-	-	-	-	
	HD64F36037G	56	-	3	3.0	5.5	20	-	2	2	1	-	1	1	-	8	Y	Y	53 (8)	Y	-	-	-	-	-	-	-	-	-	-	-	-	-	-	
H8/36057	HD64F36054	32	-	2	3.0	5.5	20	-	2	2	1	-	2	1	-	8	-	Y	53 (8)	Y	-	-	-	-	-	-	-	-	-	-	-	-	-	-	-
	HD64F36054G	32	32-56	2	3.0	5.5	20	-	2	2	1	-	2	1	-	8	Y	Y	53 (8)	Y	-	-	-	-	-	-	-	-	-	-	-	-	-	-	
	HD64F36057	56	-	3	3.0	5.5	20	-	2	2	1	-	2	1	-	8	-	Y	53 (8)	Y	-	-	-	-	-	-	-	-	-	-	-	-	-	-	
	HD64F36057G	56	-	3	3.0	5.5	20	-	2	2	1	-	2	1	-	8	Y	Y	53 (8)	Y	-	-	-	-	-	-	-	-	-	-	-	-	-	-	
H8/36049	HD64F36049HV	96	-	4	3.0	5.5	20	Y	2	3	1	1	3	-	1	8	-	Y	67 (13)	Y	-	-	-	-	-	-	-	-	-	-	-	-	-	-	
	HD64F36049GHV	96	64-96	4	3.0	5.5	20	Y	2	3	1	1	3	-	1	8	Y	Y	67 (13)	Y	-	-	-	-	-	-	-	-	-	-	-	-	-	-	
H8/36064	HD64F36064G	32	-	2	3.0	5.5	20	-	2	2	1	1	2	-	1	8	Y	Y	53 (8)	Y	-	-	-	-	-	-	-	-	-	-	-	-	-	-	
H8/36077	HD64F36074G	32	-	4	4.5	5.5	20	Y	2	2	1	1	2	-	1	8	Y	Y	55 (8)	Y	-	-	-	-	-	-	-	-	-	-	-	-	-	-	
	HD64F36077G	56	-	4	4.5	5.5	20	Y	2	2	1	1	2	-	1	8	Y	Y	55 (8)	Y	-	-	-	-	-	-	-	-	-	-	-	-	-	-	
H8/36079	HD64F36079G	128	-	6	4.5	5.5	20	Y	2	2	1	1	2	-	1	8	Y	Y	55 (8)	Y	-	-	-	-	-	-	-	-	-	-	-	-	-	-	
H8/36094	HD64F36094	32	-	2	3.0	5.5	20	Y	2	1	1	-	1	-	1	8	-	Y	39 (8)	Y	-	-	-	-	-	-	-	-	-	-	-	-	-	-	
	HD64F36094G	32	-	2	4.5	5.5	20	Y	2	1	1	-	1	-	1	8	Y	Y	39 (8)	Y	-	-	-	-	-	-	-	-	-	-	-	-	-	-	
H8/36087	HD64F36067	56	16-56	4	3.0	3.6	18	Y	2	2	1	1	2	-	1	8	-	Y	53 (8)	Y	-	-	-	-	-	-	-	-	-	-	-	-	-	-	
H8/36109	HD64F36109	128	-	5	3.0	5.5	20	Y	2	3	1	1	3	-	1	16	-	Y	87 (20)	-	-	-	-	-	-	-	-	-	-	-	-	-	-	-	
	HD64F36109G	128	-	5	3.0	5.5	20	Y	2	3	1	1	3	-	1	16	Y	Y	87 (20)	-	-	-	-	-	-	-	-	-	-	-	-	-	-	-	
H8/36902	HD64F36902G	8	2-8	1.5	3.0	5.5	12	-	1	1	1	-	1	-	-	4	Y	Y	22 (5)	Y	-	-	-	-	-	-	-	-	-	-	-	-	-	-	
H8/36912	HD64F36912G	8	4-8	1.5	3.0	5.5	12	-	2	1	1	-	1	-	-	4	Y	Y	22 (5)	Y	-	-	-	-	-	-	-	-	-	-	-	-	-	-	

Notes:

1. Please refer to the Hardware Manual for the operating voltage of Mask ROM devices.
2. This is the sum of the I/O pins + input-only + output-only.
3. High-current is defined as greater than or equal to 10mA for a signal being driven low. This pin count is included in the GPIO total.
4. Please visit Renesas website for full part number, specification, and availability of extended temperature parts.
5. Full part number includes **Package Suffix** for desired package. Refer to Appendix C for more details on part numbering.
6. Y = Yes, includes 32kHz crystal oscillator circuitry.

H8S/2100 Series Line-up

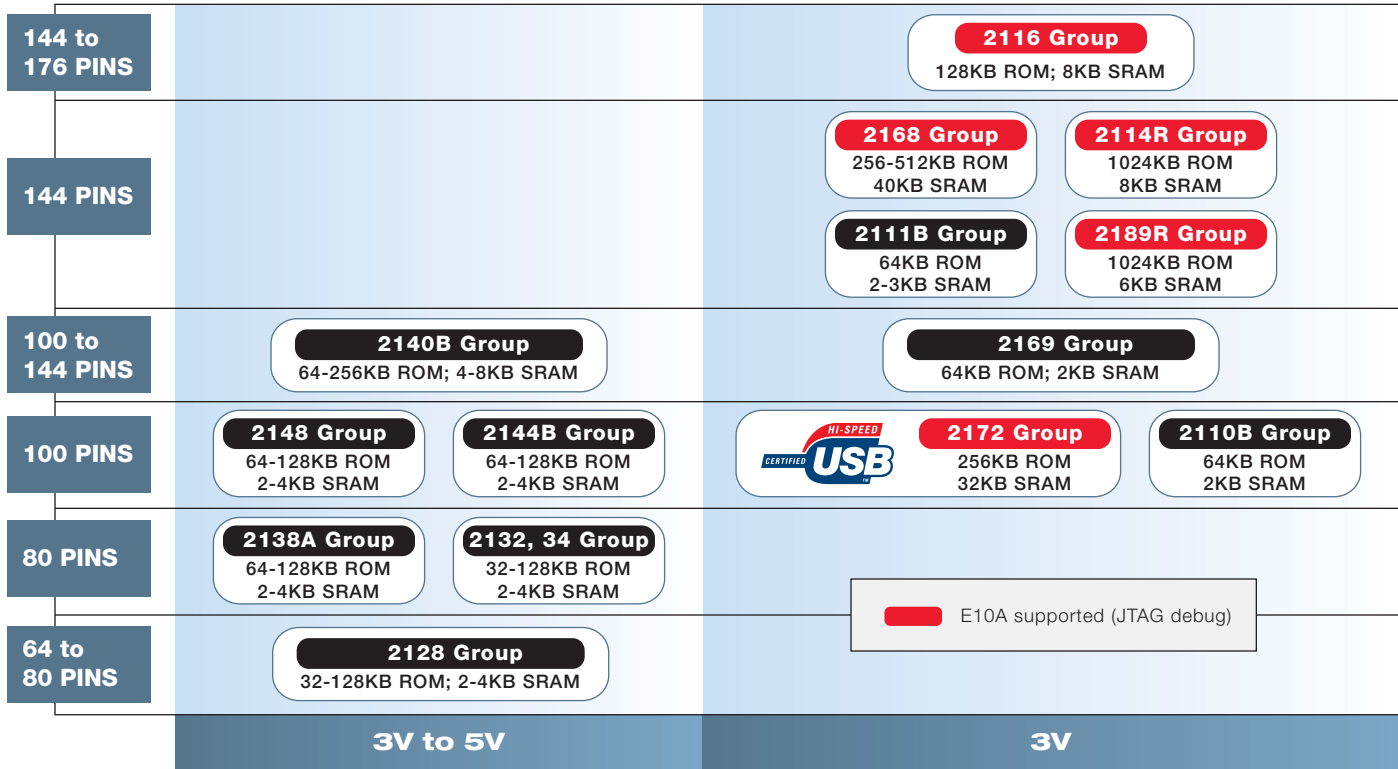

■ Features

- Up to 33MHz, low-power, 16-bit static core CPU
- 8 power-down modes for reducing power consumption
- Built-in Data Transfer Controller (DTC) with maximum of 85 channels
- Low-Pin-Count (LPC) bus interface synchronized with 33MHz PCI clock
- X-Bus (ISA) bus interface for legacy devices
- Multiple independent Inter IC (I²C™) two-wire serial bus interfaces
- IrDA interface for easy wireless connectivity
- 3-channel on-chip keyboard buffer controller conforming to PS/2 interface specification
- Built-in Bus Controller (BSC) for glueless basic bus or burst-ROM interface to external devices
- Fully integrated IPMI software available from Renesas partners
- Up to 16 PWM channels for multiple fan control

■ Applications

- Computing:** Enclosure management for servers and routers, IKAP
- Industrial:** HVAC, utility meters, GPS systems
- Automotive:** Controllers for safety systems, LCD backlight controllers
- Medical:** Controllers for health and fitness equipment
- Consumer:** Handheld products, appliances

H8S/2166 Series Block Diagram

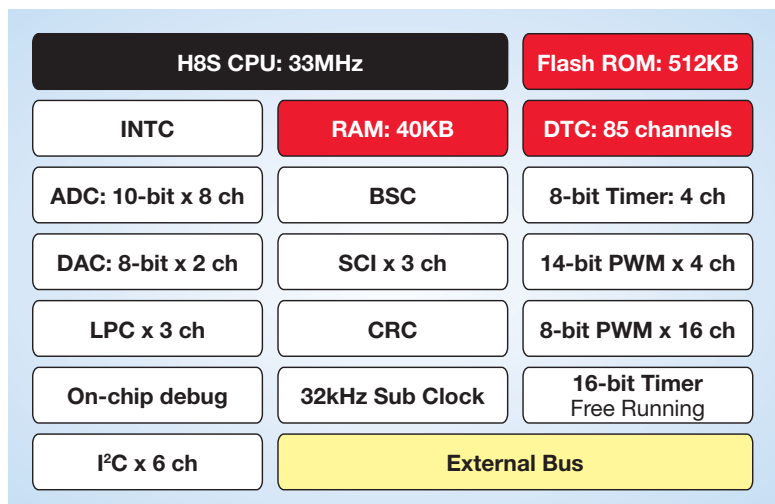

H8S/2100 Series Selector Guide

Group	Catalog Part Number	Flash (Kbytes)	Mask ROM Options (Kbytes)	RAM (Kbytes)	Vcc Min	Vcc Max	Max MHz @ Vcc Max	32 kHz Sub Clock (See Note 1)	Timers				Analog		Serial			DTC	DMA Channels	External Interrupts	GPIO [See Note 2] (High Current) [See Note 3]	External Data Bus	Extended Temp. (See Note 4)	Special Features	Package Code			
									8-bit Timers	16-bit Timers	Watchdog Timers	8-bit PWM	14-bit PWM D/A	A/D 10-bit Resolution	D/A 8-bit Resolution	Sync/Async	IrDA									Smart Card Interface	I ² C	
H8S/2110B ⁵	HD64F2110BVFA10	64	-	2	3.0	3.6	10	in	2	1	2	-	2	-	-	1	-	-	2	-	-	31	82 (6)	-	-	KBD, LPC, 3 ch PS2, 5v IO	PRQP0100KA-A PTQP0100KA-A	
	HD64F2110BVTE10	64	-	2	3.0	3.6	10	in	2	1	2	-	2	-	-	1	-	-	2	-	-	31	82 (6)	-	-			
H8S/2111B	HD64F2111BVTE10B	64	-	2	3.0	3.6	10	in	6	1	2	8	-	6	-	1	-	-	2	-	-	31	122 (6)	-	-	KBD, LPC, 3 ch PS2, 5v IO	PTQP0144LC-A PTQP0144LC-A	
	HD64F2111BVTE10C	64	-	3	3.0	3.6	10	in	6	1	2	8	-	6	-	1	-	-	2	-	-	31	122 (6)	-	-			
H8S/2114	R4F2114RVTE20V	1024	-	8	3.0	3.6	20	in	4	4	2	8	2	8	-	2	Y	Y	2	Y	-	49	119 (6)	-	-	KBD, LPC, 3 ch PS2, BSCAN, 5v IO,	PTQP0144LC-A	
H8S/2116	R4F2116VTE20V	128	-	8	3.0	3.6	20	in	4	3	2	8	2	16	-	1	-	Y	3	-	-	41	125 (40)	Y	-	LPC, PS/2	PTQP0144LC-A	
	R4F2116VBG20V	128	-	8	3.0	3.6	20	in	4	3	2	8	2	16	-	1	-	Y	3	-	-	41	125 (40)	Y	-	LPC, PS/2	PLBG0176GA-A	
H8S/2128	HD64F2128FA20V	128	Y	4	4.0	5.5	20	in	4	1	2	16	2	8	-	2	-	-	2	Y	-	4	51 (24)	Y	Y	TMC	PRQP0064GB-A PRDP0064BB-A PTQP0080KC-A PRQP0064GB-A	
	HD64F2128PS20V	128	Y	4	4.0	5.5	20	in	4	1	2	16	2	8	-	2	-	-	2	Y	-	4	51 (24)	Y	-			
	HD64F2128TF20V	128	Y	4	4.0	5.5	20	in	4	1	2	16	2	8	-	2	-	-	2	Y	-	4	51 (24)	Y	Y			
	HD64F2128VFA10V	128	Y	4	3.0	5.5	10	in	4	1	2	16	2	8	-	2	-	-	2	Y	-	4	51 (24)	Y	-			
H8S/2132 and H8S/2134 (See Note 6)	HD64F2132RFA20V	64	Y	2	4.0	5.5	20	in	3	1	2	-	2	8	2	3	Y	-	-	-	-	15	66 (24)	Y	Y	X-Bus, KBD, TMC	PRQP0080JB-A PTQP0080KC-A PRQP0080JB-A PTQP0080KC-A	
	HD64F2132RTF20V	64	Y	2	4.0	5.5	20	in	3	1	2	-	2	8	2	3	Y	-	-	-	-	15	66 (24)	Y	Y			
	HD64F2132RVFA10V	64	Y	2	3.0	5.5	10	in	3	1	2	-	2	8	2	3	Y	-	-	-	-	15	66 (24)	Y	-			
	HD64F2132RVTF10V	64	Y	2	3.0	5.5	10	in	3	1	2	-	2	8	2	3	Y	-	-	-	-	15	66 (24)	Y	-			
H8S/2138A	HD64F2138AFA20V	128	Y	4	4.0	5.5	20	in	4	1	2	16	2	8	2	3	Y	-	2	Y	-	15	66 (24)	Y	Y	X-Bus, KBD, TMC	PRQP0080JB-A PTQP0080KC-A PRQP0080JB-A PTQP0080KC-A	
	HD64F2138ATF20V	128	Y	4	4.0	5.5	20	in	4	1	2	16	2	8	2	3	Y	-	2	Y	-	15	66 (24)	Y	Y			
	HD64F2138AVFA10V	128	Y	4	2.7	3.6	10	in	4	1	2	16	2	8	2	3	Y	-	2	Y	-	15	66 (24)	Y	-			
	HD64F2138AVTF10V	128	Y	4	2.7	3.6	10	in	4	1	2	16	2	8	2	3	Y	-	2	Y	-	15	66 (24)	Y	-			
H8S/2140B ⁵	HD64F2140BVFA10V	64	-	4	2.7	3.6	10	in	4	1	2	16	2	8	2	3	Y	-	2	Y	-	31	82 (6)	Y	-	LPC, X-Bus, KBD, 3-ch PS2, TMC, 5v IO	PRQP0100KA-A PTQP0100KA-A PRQP0100KA-A PTQP0100KA-A PTQP0100KA-A PRQP0100KA-A PTQP0100KA-A HD64F2145BTE20V HD64F2145BVFA10V HD64F2145BVTE10V HD64F2148BVFA20V HD64F2148BFA20V HD64F2148BTE20V HD64F2148BVFA10V HD64F2148BVTE10V HD64F2160BVTE10V HD64F2161BVTE10V	
	HD64F2140BVTE10V	64	-	4	2.7	3.6	10	in	4	1	2	16	2	8	2	3	Y	-	2	Y	-	31	82 (6)	Y	-			
	HD64F2141BVFA10V	128	-	4	2.7	3.6	10	in	4	1	2	16	2	8	2	3	Y	-	2	Y	-	31	82 (6)	Y	-			
	HD64F2141BVTE10V	128	-	4	2.7	3.6	10	in	4	1	2	16	2	8	2	3	Y	-	2	Y	-	31	82 (6)	Y	-			
	HD64F2145BTE20V	256	-	8	4.5	5.5	20	in	4	1	2	16	2	8	2	3	Y	-	2	Y	-	31	82 (6)	Y	-			
	HD64F2145BVFA10V	256	-	8	2.7	3.6	10	in	4	1	2	16	2	8	2	3	Y	-	2	Y	-	31	82 (6)	Y	-			
	HD64F2145BVTE10V	256	-	8	2.7	3.6	10	in	4	1	2	16	2	8	2	3	Y	-	2	Y	-	31	82 (6)	Y	-			
	HD64F2148BVFA20V	128	-	4	4.0	5.5	20	in	4	1	2	16	2	8	2	3	Y	-	2	Y	-	31	82 (34)	Y	Y			
	HD64F2148BFA20V	128	-	4	4.0	5.5	20	in	4	1	2	16	2	8	2	3	Y	-	2	Y	-	31	82 (34)	Y	Y			
	HD64F2148BTE20V	128	-	4	4.0	5.5	20	in	4	1	2	16	2	8	2	3	Y	-	2	Y	-	31	82 (34)	Y	-			
	HD64F2148BVFA10V	128	-	4	2.7	3.6	10	in	4	1	2	16	2	8	2	3	Y	-	2	Y	-	31	82 (6)	Y	-			
	HD64F2148BVTE10V	128	-	4	2.7	3.6	10	in	4	1	2	16	2	8	2	3	Y	-	2	Y	-	31	82 (6)	Y	-			
	HD64F2160BVTE10V	64	-	4	2.7	3.6	10	in	4	1	2	16	2	8	2	3	Y	-	2	Y	-	31	122 (6)	Y	-			
	HD64F2161BVTE10V	128	-	4	2.7	3.6	10	in	4	1	2	16	2	8	2	3	Y	-	2	Y	-	31	122 (6)	Y	-			
H8S/2144B	HD64F2134BFA20V	128	-	4	4.0	5.5	20	in	3	1	2	-	2	8	2	3	Y	-	-	-	-	23	66 (24)	Y	Y	X-Bus, KBD, TMC	PRQP0080JB-A PTQP0080KC-A PRQP0100KA-A PTQP0100KA-A	
	HD64F2134BTE20V	128	-	4	4.0	5.5	20	in	3	1	2	-	2	8	2	3	Y	-	-	-	-	23	66 (24)	Y	Y			
	HD64F2144BFA20V	128	-	4	4.0	5.5	20	in	3	1	2	-	2	8	2	3	Y	-	-	-	-	23	82 (24)	Y	Y			
	HD64F2144BTE20V	128	-	4	4.0	5.5	20	in	3	1	2	-	2	8	2	3	Y	-	-	-	-	23	82 (24)	Y	Y			
H8S/2168	HD64F2166VTE33V	512	-	40	3.0	3.6	33	in	4	1	2	16	4	8	2	3	Y	Y	6	Y	-	41	115 (0)	Y	-	LPC, CRC, HSS, BSCAN, 5v IO, OCD	PTQP0144LC-A PTQP0144LC-A PTQP0144LC-A	
	HD64F2167VTE33V	384	-	40	3.0	3.6	33	in	4	1	2	16	4	8	2	3	Y	Y	6	Y	-	41	115 (0)	Y	-			
	HD64F2168VTE33V	256	-	40	3.0	3.6	33	in	4	1	2	16	4	8	2	3	Y	Y	6	Y	-	41	115 (0)	Y	-			
H8S/2169	HD64F2149YVTE10V	64	-	2	2.7	3.6	10	in	4	1	2	16	2	8	2	3	Y	-	2	Y	-	9	82 (6)	Y	-	LPC, X-Bus, KBD, 3-ch PS2, TMC	PTQP0100KA-A PTQP0144LC-A	
	HD64F2169YVTE10V	64	-	2	2.7	3.6	10	in	4	1	2	16	2	8	2	3	Y	-	2	Y	-	9	122 (6)	Y	-			
H8S/2172	HD64F2170VTE33V	256	-	32	3.0	3.6	33	-	2	-	1	-	-	-	-	1	-	-	-	-	4	9	76 (0)	Y	-	USBH, DRAMC	PTQP0100KA-A	
H8S/2189R	R4F2189VTE20V	1024	-	6	3.0	3.6	20	in	4	4	2	8	2	8	-	2	Y	Y	2	-	-	49	119 (15)	-	-	IP protect, 5v IO	PTQP0144LC-A	

Notes:

- “in” = external 32KHz clock input for sub clock mode.
- This is the sum of the I/O pins + input-only + output-only.
- High-current is defined as greater than or equal to 10mA for a signal being driven low. This pin count is included in the GPIO total.
- Please visit Renesas website for full part number, specification, and availability of extended temperature parts.
- This group contains a specific voltage supply for some of the GPIO pins. Please refer to the Hardware Manual for full specifications of these pins and voltages.
- For H8S/2134 devices, please refer to the H8S/2144B Group Hardware Manual.

H8S/2200 Series Line-up

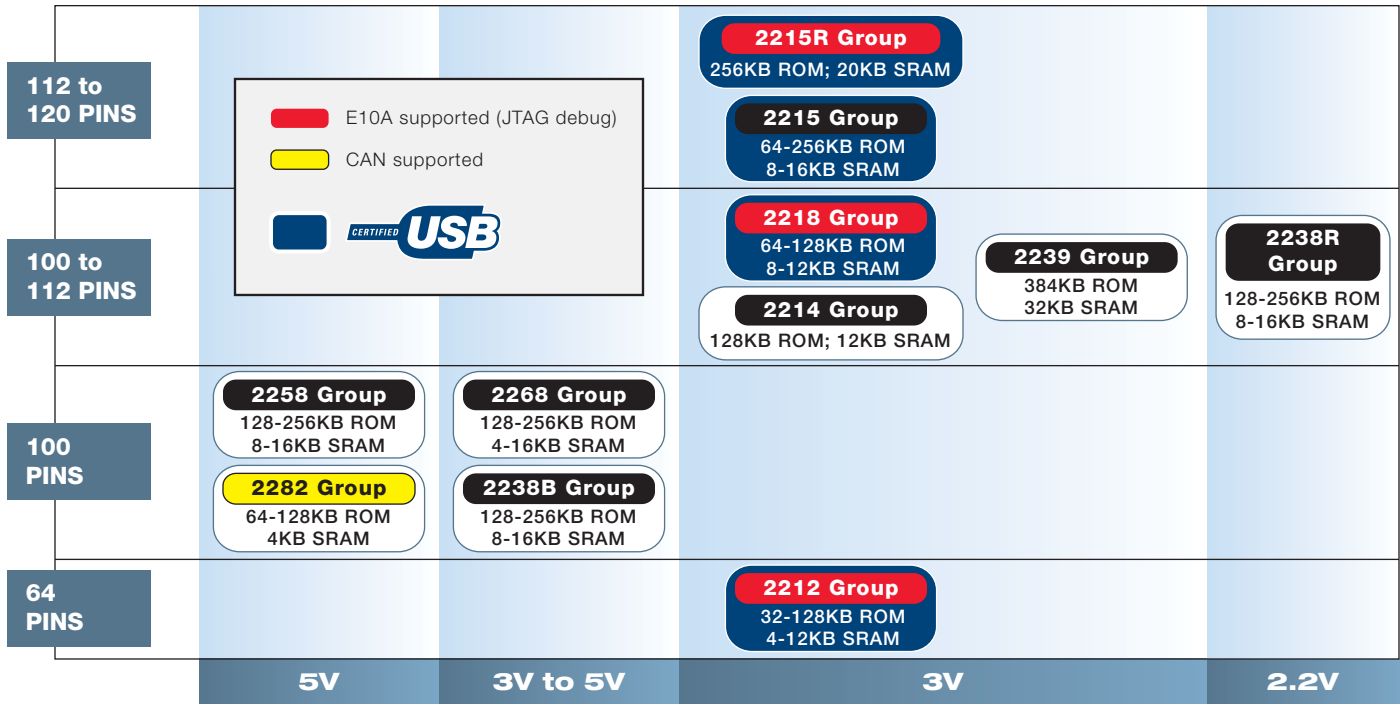

■ Features

- Up to 24MHz, low-power, 16-bit static CPU
- 8 power-down modes for reducing power consumption
- 32kHz sub-clock oscillator circuit allows CPU to be switched to sub-active mode to save power
- Built-in Data Transfer Controller (DTC) with maximum of 85 channels
- Built-in DMA controller (DMAC) with maximum of 4 channels
- Bus-powered/self-powered on-chip USB (v2.0 full speed) core for easy serial connectivity
- 40-segment on-chip LCD controller with voltage booster circuit
- Supports Smart Card interface conforming to ISO/IEC 7816-3
- Multi-channel Inter IC (I²C™) two-wire serial bus interface
- Built-in Bus Controller (BSC) provides glueless basic bus or burst-ROM I/F
- Miniature BGA packages smaller than 10mm (per side) with thickness equal to 1.2mm

■ Applications

- Computing:** Keyboard controllers, USB slaves, serial-mode converters, power-monitors
- Metering:** Electric meters, gas meters, water meters, thermostats
- Medical:** Glucose monitors, drug-pump monitors, heart-rate monitors, ambulatory IV pumps
- Industrial/Commercial:** Emissions test equipment, automotive diagnostic instruments, data loggers, barcode scanner
- Network/Communication:** Communication protocol converters, GPS systems

H8S/2215R Series Block Diagram

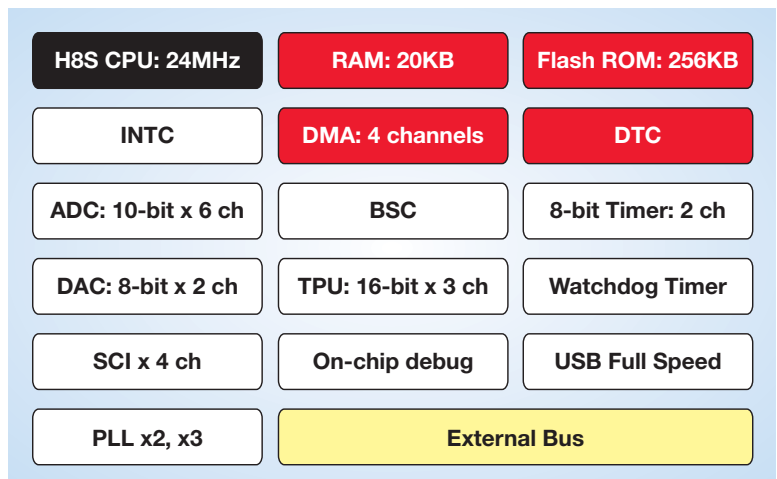

H8S/2300 Series Line-up

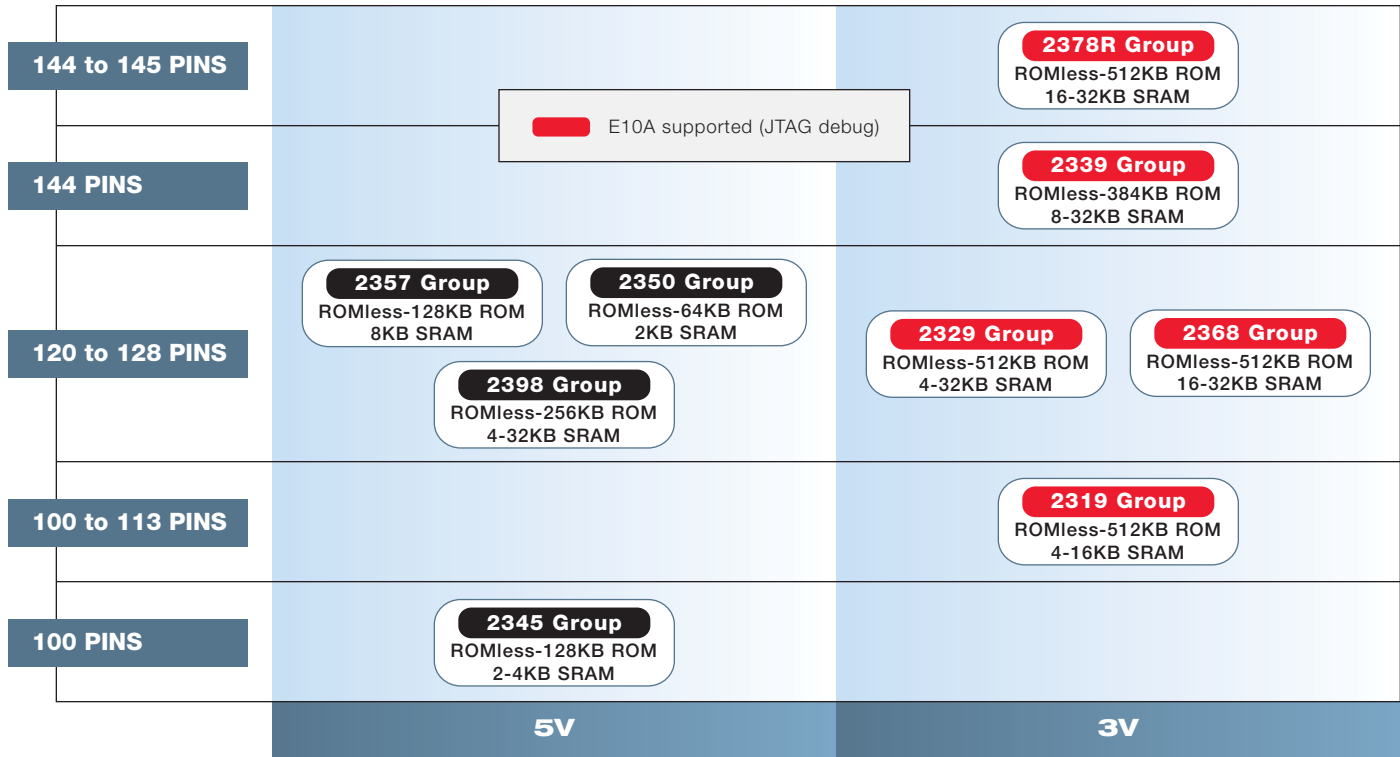

■ Features

- Up to 35MHz, low-power, 16-bit static CPU
- 6 power-down modes for reducing power consumption
- Built-in Data Transfer Controller (DTC) with max. 85 channels
- Built-in DMA controller (DMAC) with maximum of 4 channels
- IrDA Interface for easy wireless connectivity
- Supports Smart Card interface conforming to ISO/IEC 7816-3
- 16-bit PPG with up to four different 4-bit group outputs
- Built-in Bus Controller (BSC) with arbitration bus to manage basic bus or burst-ROM interface
- Miniature BGA packages smaller than 10mm (per side) with thickness equal to 1.2mm

■ Applications

Computing: Printers, label printers, touch screen controllers, CD R/W drives

Industrial: Data analyzers, emission test equipment, GPS systems, Barcode scanners

Automotive: Car audio, automotive diagnostic equipment

Medical: Blood oxygen monitors, drug pump monitors, heart rate monitors

Network/Communication: LAN hubs, GPS systems

H8S/2378R Series Block Diagram

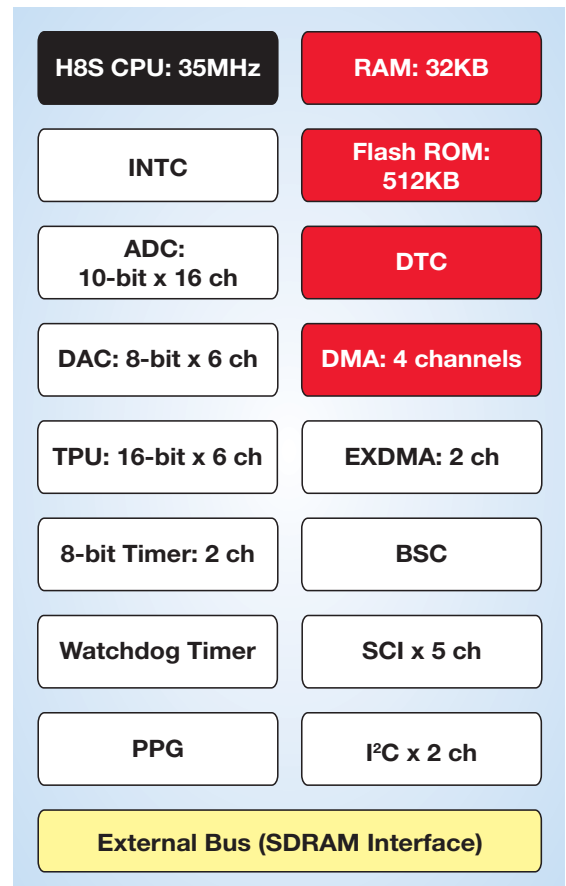

H8S/2300 Series Selector Guide — Part 1 of 2

Group	Catalog Part Number	Flash (Kbytes)	Mask ROM Options (Kbytes)	RAM (Kbytes)	Vcc Min	Vcc Max	Max MHz @ Vcc Max	8-bit Timers	16-bit Timers	Watchdog Timers	Waveform Generator (PPG)	A/D 10-bit Resolution	D/A 8-bit Resolution	Serial (Sync/Async)	IrDA	Smart Card Interface	ƒC	DTC	DMA Channels	External Interrupts	GPIO [See Note 1] (High Current) [See Note 2]	External Data Bus	Extended Temperature (See Note 3)	Special Features	Package Code
H8S/2319	HD6412312SVF20V	-	-	8	3.0	3.6	20	2	6	1	-	8	2	2	-	Y	-	Y	-	9	79 (0)	Y	-		PRQP0100JE-B
	HD6412312SVF25V	-	-	8	3.0	3.6	25	2	6	1	-	8	2	2	-	Y	-	Y	-	9	79 (0)	Y	-		PRQP0100JE-B
	HD6412312SVTE20V	-	-	8	3.0	3.6	20	2	6	1	-	8	2	2	-	Y	-	Y	-	9	79 (0)	Y	-		PTQP0100KA-A
	HD6412312SVTE25V	-	-	8	3.0	3.6	25	2	6	1	-	8	2	2	-	Y	-	Y	-	9	79 (0)	Y	-		PTQP0100KA-A
	HD64F2314VTE25V	384	Y	4	3.0	3.6	25	2	6	1	-	8	2	2	-	Y	-	Y	-	9	79 (0)	Y	-		PTQP0100KA-A
	HD64F2315VF25V	384	Y	8	3.0	3.6	25	2	6	1	-	8	2	2	-	Y	-	Y	-	9	79 (0)	Y	-		PRQP0100JE-B
	HD64F2315VTE25V	384	Y	8	3.0	3.6	25	2	6	1	-	8	2	2	-	Y	-	Y	-	9	79 (0)	Y	-		PTQP0100KA-A
	HD64F2317VTE25V	128	Y	8	3.0	3.6	25	2	6	1	-	8	2	2	-	Y	-	Y	-	9	79 (0)	Y	-		PTQP0100KA-A
	HD64F2317VTF25V	128	Y	8	3.0	3.6	25	2	6	1	-	8	2	2	-	Y	-	Y	-	9	79 (0)	Y	-		PTQP0100LC-A
	HD64F2318VF25V	256	Y	8	3.0	3.6	25	2	6	1	-	8	2	2	-	Y	-	Y	-	9	79 (0)	Y	-		PRQP0100JE-B
	HD64F2318VTE25V	256	Y	8	3.0	3.6	25	2	6	1	-	8	2	2	-	Y	-	Y	-	9	79 (0)	Y	-		PTQP0100KA-A
	HD64F2318VTF25V	256	Y	8	3.0	3.6	25	2	6	1	-	8	2	2	-	Y	-	Y	-	9	79 (0)	Y	-		PTQP0100LC-A
	HD64F2319CVF25V	512	-	16	3.0	3.6	25	2	6	1	-	8	2	2	-	Y	-	Y	-	9	79 (0)	Y	-		PRQP0100JE-B
	HD64F2319CVLP25V	512	-	16	3.0	3.6	25	2	6	1	-	8	2	2	-	Y	-	Y	-	9	79 (0)	Y	-		PTL0113JA
	HD64F2319CVTE25V	512	-	16	3.0	3.6	25	2	6	1	-	8	2	2	-	Y	-	Y	-	9	79 (0)	Y	-		PTQP0100KA-A
	HD64F2319EVF25V	512	Y	8	3.0	3.6	25	2	6	1	-	8	2	2	-	Y	-	Y	-	9	79 (0)	Y	-		PRQP0100JE-B
	HD64F2319EVTE25V	512	Y	8	3.0	3.6	25	2	6	1	-	8	2	2	-	Y	-	Y	-	9	79 (0)	Y	-		PTQP0100KA-A
HD64F2319VF25V	512	Y	8	3.0	3.6	25	2	6	1	-	8	2	2	-	Y	-	Y	-	9	79 (0)	Y	-		PRQP0100JE-B	
HD64F2319VTE25V	512	Y	8	3.0	3.6	25	2	6	1	-	8	2	2	-	Y	-	Y	-	9	79 (0)	Y	-		PTQP0100KA-A	
H8S/2329	HD6412320VF20V	-	-	4	2.7	3.6	20	2	6	1	16	8	2	3	-	Y	-	Y	4	9	95 (0)	Y	-	DRAMC	PRQP0128KB-A
	HD6412320VF25V	-	-	4	3.0	3.6	25	2	6	1	16	8	2	3	-	Y	-	Y	4	9	95 (0)	Y	-		PRQP0128KB-A
	HD6412320VTE20V	-	-	4	2.7	3.6	20	2	6	1	16	8	2	3	-	Y	-	Y	4	9	95 (0)	Y	-		PTQP0120LA-A
	HD6412320VTE25V	-	-	4	3.0	3.6	25	2	6	1	16	8	2	3	-	Y	-	Y	4	9	95 (0)	Y	-		PTQP0120LA-A
	HD6412321VF20V	-	-	4	2.7	3.6	20	2	6	1	16	8	2	3	-	Y	-	Y	-	9	95 (0)	Y	-		PRQP0128KB-A
	HD6412321VF25V	-	-	4	3.0	3.6	25	2	6	1	16	8	2	3	-	Y	-	Y	-	9	95 (0)	Y	-		PRQP0128KB-A
	HD6412321VTE20V	-	-	4	2.7	3.6	20	2	6	1	16	8	2	3	-	Y	-	Y	-	9	95 (0)	Y	-		PTQP0120LA-A
	HD6412321VTE25V	-	-	4	3.0	3.6	25	2	6	1	16	8	2	3	-	Y	-	Y	-	9	95 (0)	Y	-		PTQP0120LA-A
	HD6412322RVF20V	-	-	8	2.7	3.6	20	2	6	1	16	8	2	3	-	Y	-	Y	4	9	95 (0)	Y	-		PRQP0128KB-A
	HD6412322RVF25V	-	-	8	3.0	3.6	25	2	6	1	16	8	2	3	-	Y	-	Y	4	9	95 (0)	Y	-		PRQP0128KB-A
	HD6412322RVTE20V	-	-	8	2.7	3.6	20	2	6	1	16	8	2	3	-	Y	-	Y	4	9	95 (0)	Y	-		PTQP0120LA-A
	HD6412322RVTE25V	-	-	8	3.0	3.6	25	2	6	1	16	8	2	3	-	Y	-	Y	4	9	95 (0)	Y	-		PTQP0120LA-A
	HD6412324SVF25V	-	-	32	3.0	3.6	25	2	6	1	16	8	2	3	-	Y	-	Y	4	9	95 (0)	Y	-		PRQP0128KB-A
	HD6412324SVTE20V	-	-	32	2.7	3.6	20	2	6	1	16	8	2	3	-	Y	-	Y	4	9	95 (0)	Y	-		PTQP0120LA-A
	HD6412324SVTE25V	-	-	32	3.0	3.6	25	2	6	1	16	8	2	3	-	Y	-	Y	4	9	95 (0)	Y	-		PTQP0120LA-A
	HD64F2326CVF25V	512	-	16	3.0	3.6	25	2	6	1	16	8	2	3	-	Y	-	Y	4	9	95 (0)	Y	-		PRQP0128KB-A
	HD64F2326CVTE25V	512	-	16	3.0	3.6	25	2	6	1	16	8	2	3	-	Y	-	Y	4	9	95 (0)	Y	-		PTQP0120LA-A
HD64F2326VF25V	512	-	8	3.0	3.6	25	2	6	1	16	8	2	3	-	Y	-	Y	4	9	95 (0)	Y	-		PRQP0128KB-A	
HD64F2326VTE25V	512	-	8	3.0	3.6	25	2	6	1	16	8	2	3	-	Y	-	Y	4	9	95 (0)	Y	-		PTQP0120LA-A	
HD64F2328BVF25V	256	Y	8	3.0	3.6	25	2	6	1	16	8	2	3	-	Y	-	Y	4	9	95 (0)	Y	-		PRQP0128KB-A	
HD64F2328BVTE25V	256	Y	8	3.0	3.6	25	2	6	1	16	8	2	3	-	Y	-	Y	4	9	95 (0)	Y	-		PTQP0120LA-A	
HD64F2329BVF25V	384	-	32	3.0	3.6	25	2	6	1	16	8	2	3	-	Y	-	Y	4	9	95 (0)	Y	-		PRQP0128KB-A	
HD64F2329BVTE25V	384	-	32	3.0	3.6	25	2	6	1	16	8	2	3	-	Y	-	Y	4	9	95 (0)	Y	-		PTQP0120LA-A	
HD64F2329EVF25V	384	-	32	3.0	3.6	25	2	6	1	16	8	2	3	-	Y	-	Y	4	9	95 (0)	Y	-		PRQP0128KB-A	
HD64F2329EVTE25V	384	-	32	3.0	3.6	25	2	6	1	16	8	2	3	-	Y	-	Y	4	9	95 (0)	Y	-		PTQP0120LA-A	
H8S/2339	HD6412332VFC20V	-	-	8	2.7	3.6	20	2	6	1	16	12	4	3	-	Y	-	Y	4	9	118 (0)	Y	-		PRQP0144KA-A
	HD6412332VFC25V	-	-	8	3.0	3.6	25	2	6	1	16	12	4	3	-	Y	-	Y	4	9	118 (0)	Y	-		PRQP0144KA-A
	HD64F2338VFC25V	256	Y	8	3.0	3.6	25	2	6	1	16	12	4	3	-	Y	-	Y	4	9	118 (0)	Y	-		PRQP0144KA-A
	HD64F2339EVFC25V	384	-	32	3.0	3.6	25	2	6	1	16	12	4	3	-	Y	-	Y	4	9	118 (0)	Y	-		PRQP0144KA-A
HD64F2339VFC25V	384	-	32	3.0	3.6	25	2	6	1	16	12	4	3	-	Y	-	Y	4	9	118 (0)	Y	-		PRQP0144KA-A	

(The H8S/2300 Series Selector Guide is continued on page 31)

Notes:

1. This is the sum of the I/O pins + input-only + output-only.
2. High-current is defined as greater than or equal to 10mA for a signal being driven low. This pin count is included in the GPIO total.
3. Please visit Renesas website for full part number, specification, and availability of extended temperature parts.

When it comes to USB,
H8 stands in front.

simplicity + greater design versatility

H8 Microcontrollers Can Be Self-Powered or USB Bus-Powered

With Renesas H8 devices, there's no need to create two designs to satisfy different power requirements for applications that use USB links. Selection of self-powered or USB-bus powered operation is made via an input pin. Either way, when the USB cable is disconnected from your system, the microcontroller is automatically put into a defined state, a powered-down mode. A simple, effective solution. Apply it and see for yourself!



Guide to USB-compatible H8S Devices

Group	ROM/RAM/Speed	Features
USB 2.0 Full-Speed [Bulk, Interrupt, Control transfers supported]		
H8S/2212	128KB/12KB/24MHz	Single Chip, Sub Clock, On-Chip Debugger
H8S/2211	64KB/8KB/24MHz	USB FIFO: 456 Bytes Package: 64-pin QFP
H8S/2218	128KB/12KB/24MHz	Sub Clock, On-Chip Debugger
H8S/2218		USB FIFO: 456 Bytes Package: 100-pin QFP
H8SX/1664	512KB/40KB/48MHz	On-Chip Debugger
H8SX/1663	384KB/40KB/48MHz	USB FIFO: 288 Bytes Package: 144-pin LQFP
H8SX/1654	512KB/40KB/48MHz	On-Chip Debugger
H8SX/1653	384KB/40KB/48MHz	USB FIFO: 288 Bytes Package: 120-pin QFP
USB 2.0 Full-Speed [Isochronous, Bulk, Interrupt, Control transfers supported]		
H8S/2215	256KB/16KB/16MHz	USB FIFO: 1288 Bytes
H8S/2215		Packages: 120-pin QFP, 112-pin BGA
H8S/2215R	256KB/20KB/24MHz	On-Chip Debugger, USB Cera Lock Support
H8S/2215R		USB FIFO: 1288 Bytes
H8S/2215R		Packages: 120-pin QFP, 112-pin BGA
USB 2.0 High-Speed/Full-Speed [Bulk, Interrupt, Control transfers supported]		
H8S/2170B	256KB/32KB/33MHz	On-Chip Debugger
H8S/2170B		USB FIFO: 1224 Bytes Package: 100-pin QFP

H8S/2300 Series Selector Guide — Part 2 of 2

Group	Catalog Part Number	Flash (Kbytes)	Mask ROM Options (Kbytes)	RAM (Kbytes)	Vcc Min	Vcc Max	Max MHz @ Vcc Max	8-bit Timers	16-bit Timers	Watchdog Timers	Waveform Generator (PPG)	A/D 10-bit Resolution	D/A 8-bit Resolution	Serial (Sync/Async)	IrDA	Smart Card Interface	i ² C	DTC	DMA Channels	External Interrupts	GPIO [See Note 1] (High Current) [See Note 2]	External Data Bus	Extended Temperature (See Note 3)	Special Features	Package Code
H8S/2345	HD6412340FA10V	-	-	2	2.7	5.5	10	2	6	1	-	8	2	2	-	Y	-	Y	-	9	79 (28)	Y	Y		PRQP0100KA-A PRQP0100KA-A PTQP0100KA-A
	HD6412340FA20V	-	-	2	4.5	5.5	20	2	6	1	-	8	2	2	-	Y	-	Y	-	9	79 (28)	Y	Y		PRQP0100JE-B PRQP0100KA-A PTQP0100KA-A
	HD6412340TE20V	-	-	2	4.5	5.5	20	2	6	1	-	8	2	2	-	Y	-	Y	-	9	79 (28)	Y	Y		PRQP0100KA-A PRQP0100KA-A PTQP0100KA-A
	HD64F2345F20V	128	Y	4	4.5	5.5	20	2	6	1	-	8	2	2	-	Y	-	Y	-	9	79 (28)	Y	Y		PRQP0100KA-A PRQP0100KA-A PTQP0100KA-A
	HD64F2345FA20V	128	Y	4	4.5	5.5	20	2	6	1	-	8	2	2	-	Y	-	Y	-	9	79 (28)	Y	Y		PRQP0100KA-A PRQP0100KA-A PTQP0100KA-A
	HD64F2345TE20V	128	Y	4	4.5	5.5	20	2	6	1	-	8	2	2	-	Y	-	Y	-	9	79 (28)	Y	Y		PRQP0100KA-A PRQP0100KA-A PTQP0100KA-A
H8S/2357	HD6412352F13V	-	-	8	3.0	5.5	13	2	6	1	16	8	2	3	-	Y	-	Y	4	9	95 (32)	Y	-		PRQP0128KB-A PRQP0128KB-A PTQP0120LA-A
	HD6412352F20V	-	-	8	4.5	5.5	20	2	6	1	16	8	2	3	-	Y	-	Y	4	9	95 (32)	Y	-		PRQP0128KB-A PRQP0128KB-A PTQP0120LA-A
	HD6412352TE13V	-	-	8	3.0	5.5	13	2	6	1	16	8	2	3	-	Y	-	Y	4	9	95 (32)	Y	-		PRQP0128KB-A PRQP0128KB-A PTQP0120LA-A
	HD6412352TE20V	-	-	8	4.5	5.5	20	2	6	1	16	8	2	3	-	Y	-	Y	4	9	95 (32)	Y	-		PRQP0128KB-A PRQP0128KB-A PTQP0120LA-A
	HD64F2357F20V	128	Y	8	4.5	5.5	20	2	6	1	16	8	2	3	-	Y	-	Y	4	9	95 (32)	Y	-		PRQP0128KB-A PRQP0128KB-A PTQP0120LA-A
	HD64F2357TE20V	128	Y	8	4.5	5.5	20	2	6	1	16	8	2	3	-	Y	-	Y	4	9	95 (32)	Y	-		PRQP0128KB-A PRQP0128KB-A PTQP0120LA-A
	HD64F2357VF13V	128	Y	8	3.0	5.5	13	2	6	1	16	8	2	3	-	Y	-	Y	4	9	95 (32)	Y	-		PRQP0128KB-A PRQP0128KB-A PTQP0120LA-A
HD64F2357VTE13V	128	Y	8	3.0	5.5	13	2	6	1	16	8	2	3	-	Y	-	Y	4	9	95 (32)	Y	-		PRQP0128KB-A PRQP0128KB-A PTQP0120LA-A	
H8S/2368	HD64F2360VTE33V ⁴	256	Y	16	3.0	3.6	33	2	6	1	16	10	2	5	Y	Y	2	Y	4	9	94 (0)	Y	-		TPTQ0120LA-A TPTQ0120LA-A
	HD64F2361VTE33V ⁴	256	-	24	3.0	3.6	33	2	6	1	16	10	2	5	Y	Y	2	Y	4	9	94 (0)	Y	-		TPTQ0120LA-A TPTQ0120LA-A
	HD64F2362VTE33V	256	-	32	3.0	3.6	33	2	6	1	16	10	2	5	Y	Y	2	Y	4	9	94 (0)	Y	-		TPTQ0120LA-A TPTQ0120LA-A
	HD6412363VF33V	-	-	16	3.0	3.6	33	2	6	1	16	10	2	5	Y	Y	2	Y	4	9	94 (0)	Y	-		PRQP0128KB-A PRQP0120LA-A PTQP0120LA-A
	HD6412363VTE33V	-	-	16	3.0	3.6	33	2	6	1	16	10	2	5	Y	Y	2	Y	4	9	94 (0)	Y	-		TPTQ0120LA-A
	HD64F2364VTE33V ⁴	384	-	32	3.0	3.6	33	2	6	1	16	10	2	5	Y	Y	2	Y	4	9	94 (0)	Y	-		TPTQ0120LA-A
	HD64F2366VF33V	384	-	30	3.0	3.6	33	2	6	1	-	10	2	5	Y	Y	2	Y	-	9	94 (0)	Y	-		PRQP0128KB-A PTQP0120LA-A
	HD64F2366VTE33V	384	-	30	3.0	3.6	33	2	6	1	-	10	2	5	Y	Y	2	Y	-	9	94 (0)	Y	-		HSS
	HD64F2367VF33V	384	-	24	3.0	3.6	33	2	6	1	16	10	2	5	Y	Y	2	Y	4	9	94 (0)	Y	-		DRAMC, HSS, BT
	HD64F2367VTE33V	384	-	24	3.0	3.6	33	2	6	1	16	10	2	5	Y	Y	2	Y	4	9	94 (0)	Y	-		DRAMC, HSS, BT
	HD64F2368VTE33V	512	-	32	3.0	3.6	34	2	6	1	16	10	2	5	Y	Y	2	Y	4	9	94 (0)	Y	-		DRAMC, HSS
H8S/2378R	HD6412370VFQ34V ⁴	256	Y	16	3.0	3.6	34	2	6	1	16	16	6	5	Y	Y	2	Y	4	17	113 (0)	Y	-		PLQP0144KC-A PLQP0144KC-A
	HD6412370RVFQ34V ⁴	256	Y	16	3.0	3.6	34	2	6	1	16	16	6	5	Y	Y	2	Y	4	17	113 (0)	Y	-		PLQP0144KC-A PLQP0144KC-A
	HD6412371VFQ34V ⁴	256	-	24	3.0	3.6	34	2	6	1	16	16	6	5	Y	Y	2	Y	4	17	113 (0)	Y	-		PLQP0144KC-A PLQP0144KC-A
	HD6412371RVFQ34V ⁴	256	-	24	3.0	3.6	34	2	6	1	16	16	6	5	Y	Y	2	Y	4	17	113 (0)	Y	-		PLQP0144KC-A PLQP0144KC-A
	HD6412372VFQ34V ⁴	256	-	32	3.0	3.6	34	2	6	1	16	16	6	5	Y	Y	2	Y	4	17	113 (0)	Y	-		PLQP0144KC-A
	HD6412372RVFQ34V ⁴	256	-	32	3.0	3.6	34	2	6	1	16	16	6	5	Y	Y	2	Y	4	17	113 (0)	Y	-		PLQP0144KC-A
	HD6412373RVFQ33V	-	-	16	3.0	3.6	33	2	6	1	16	16	2	5	Y	Y	2	Y	4	17	113 (0)	Y	-		SDRAMC, HSS
	HD6412374VFQ34V ⁴	384	-	32	3.0	3.6	34	2	6	1	16	16	6	5	Y	Y	2	Y	4	17	113 (0)	Y	-		DRAMC, HSS
	HD6412374RVFQ34V ⁴	384	-	32	3.0	3.6	34	2	6	1	16	16	6	5	Y	Y	2	Y	4	17	113 (0)	Y	-		DRAMC, HSS
	HD64F2376VFQ33V	384	-	30	3.0	3.6	33	2	6	1	16	16	4	5	Y	Y	2	Y	6	17	113 (0)	Y	-		HSS
	HD64F2377RVFQ33V	384	-	24	3.0	3.6	33	2	6	1	16	16	6	5	Y	Y	2	Y	6	17	113 (0)	Y	-		SDRAMC, HSS, BT,
	HD64F2377RVFQ33VWV	384	-	24	3.0	3.6	33	2	6	1	16	16	6	5	Y	Y	2	Y	6	17	113 (0)	Y	-		2 ch EXDMAC
	HD64F2378BVLP35V	512	-	32	3.0	3.6	35	2	6	1	16	16	6	5	Y	Y	2	Y	6	17	113 (0)	Y	-		DRAMC, HSS,
	HD64F2378BVLP35V	512	-	32	3.0	3.6	35	2	6	1	16	16	6	5	Y	Y	2	Y	6	17	113 (0)	Y	-		2 ch EXDMAC
	HD64F2378RVFQ34V	512	-	32	3.0	3.6	34	2	6	1	16	16	6	5	Y	Y	2	Y	6	17	113 (0)	Y	-		SDRAMC, HSS,
H8S/2398	HD6412390F20V	-	-	4	4.5	5.5	20	2	6	1	16	8	2	3	-	Y	-	Y	4	9	95 (32)	Y	-		PRQP0128KB-A PTQP0120LA-A
	HD6412390TE20V	-	-	4	4.5	5.5	20	2	6	1	16	8	2	3	-	Y	-	Y	4	9	95 (32)	Y	-		PRQP0128KB-A PTQP0120LA-A
	HD6412392F20V	-	-	8	4.5	5.5	20	2	6	1	16	8	2	3	-	Y	-	Y	4	9	95 (32)	Y	-		PRQP0128KB-A PTQP0120LA-A
	HD6412392TE20V	-	-	8	4.5	5.5	20	2	6	1	16	8	2	3	-	Y	-	Y	4	9	95 (32)	Y	-		PRQP0128KB-A PTQP0120LA-A
	HD6412394F20V	-	-	32	4.5	5.5	20	2	6	1	16	8	2	3	-	Y	-	Y	4	9	95 (32)	Y	-		PRQP0128KB-A PTQP0120LA-A
	HD6412394TE20V	-	-	32	4.5	5.5	20	2	6	1	16	8	2	3	-	Y	-	Y	4	9	95 (32)	Y	-		PRQP0128KB-A PTQP0120LA-A
	HD64F2398F20V	256	Y	8	4.5	5.5	20	2	6	1	16	8	2	3	-	Y	-	Y	4	9	95 (32)	Y	-		PRQP0128KB-A PTQP0120LA-A
	HD64F2398TE20V	256	Y	8	4.5	5.5	20	2	6	1	16	8	2	3	-	Y	-	Y	4	9	95 (32)	Y	-		PRQP0128KB-A PTQP0120LA-A

Notes:

1. This is the sum of the I/O pins + input-only + output-only.
2. High-current is defined as greater than or equal to 10mA for a signal being driven low. This pin count is included in the GPIO total.
3. Please visit Renesas website for full part number, specification, and availability of extended temperature parts.
4. The specification for this device is subject to change.

H8S/2400/2500 Series Line-up

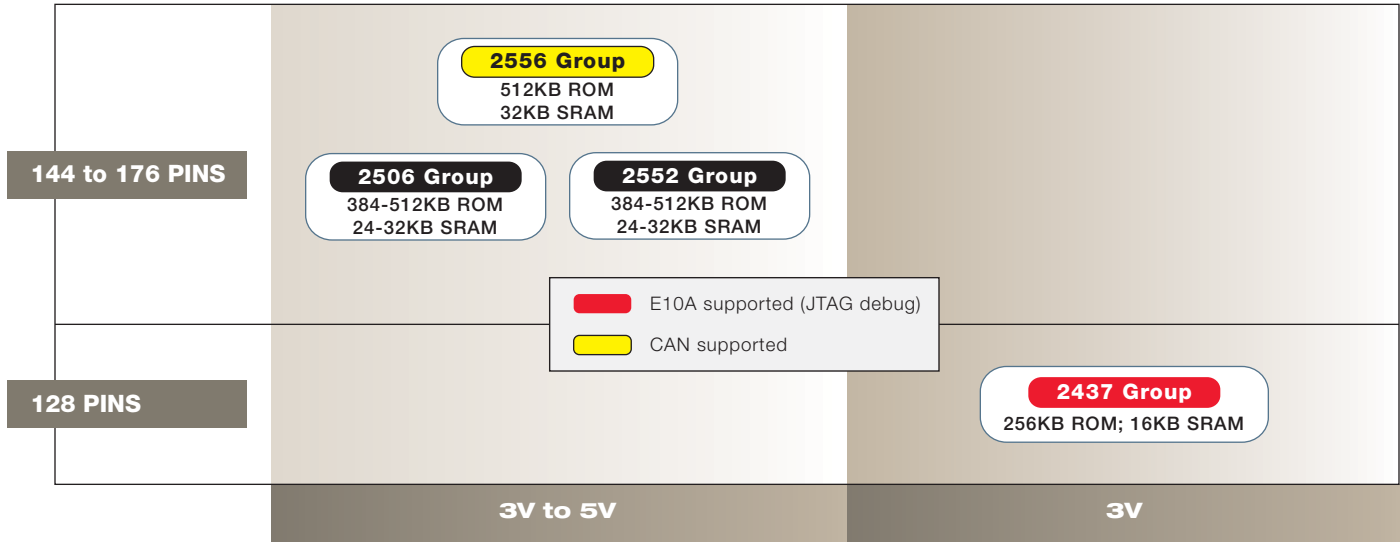

■ Features for H8S/2400 Series

- Up to 20MHz, 16 bit CISC CPU with Hardware Multiply Accumulate Block (H8S/2600 CPU)
- 8 power-down modes for reducing power consumption
- 32kHz sub-clock oscillator
- Support Smart Card interface conforming to ISO/IEC 7816-3

■ Features for H8S/2500 Series

- Up to 26MHz, 16 bit CISC CPU
- 6 power-down modes for reducing power consumption
- 32kHz sub-clock oscillator
- Built-in Data Transfer Controller (DTC) with maximum of 85 channels
- Up to 2-channel Controller Area Network (CAN v2.0) controller
- Support Smart Card interface conforming to ISO/IEC 7816-3
- Dual 3V and 5V I/O functions supported

H8S/2556 Block Diagram

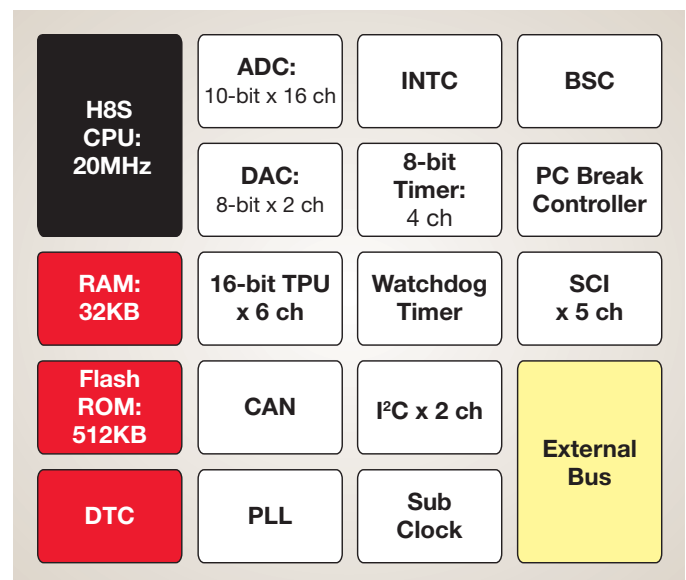

■ Applications

H8S/2400 Series: LCD Monitor, LCD-TV, Plasma-TV, projectors, home electronics

H8S/2500 Series: Audio, automotive audio

H8S/2400 and H8S/2500 Series Selector Guide

Group	Part Number	Flash (Kbytes)	FRAM (Kbytes)	Vcc			VccIO		32 kHz Sub Clock (See Note 1)	Timers					Analog		Serial				GPIO					Special Features	Package Code
				Min	Max	@ Vcc Max	Min	Max		8-bit Timers	16-bit Timers	Watchdog Timers	8-bit PWM	14-bit PWM D/A	A/D 10-bit Resolution	D/A 8-bit Resolution	Serial (Sync/Async)	IrDA	Smart Card Interface	I ² C	DTC	External Interrupts	GPIO (See Note 2)	External Data Bus	Extended Temp. (See Note 3)		
H8S/2437	HD64F2437FV	256	16	3.0	3.6	20	-	-	-	4	5	1	8	2	16	-	5	-	-	4	-	9	110	Y	-	DMC, TMC, 5v IO, Bus Trace	PRQP0128KB-A
H8S/2506	HD64F2505BR26DV	384	32	3.0	5.5	26	3.0	5.5	Y	4	6	2	-	-	16	2	5	-	Y	2	Y	9	120	Y	Y	PC Break, Dual Vcc IO	PLBG0176GA-A
	HD64F2505FC26V	384	32	3.0	5.5	26	3.0	5.5	Y	4	6	2	-	-	16	2	5	-	Y	2	Y	9	120	Y	Y		PRQP0144KB-A
	HD64F2506BR26DV	512	32	3.0	5.5	26	3.0	5.5	Y	4	6	2	-	-	16	2	5	-	Y	2	Y	9	120	Y	Y		PLBG0176GA-A
	HD64F2506FC26V	512	32	3.0	5.5	26	3.0	5.5	Y	4	6	2	-	-	16	2	5	-	Y	2	Y	9	120	Y	Y		PRQP0144KB-A
H8S/2552	HD64F2551BR26DV	384	24	3.0	5.5	26	3.0	5.5	Y	4	6	2	-	-	16	2	5	-	Y	2	Y	9	120	Y	Y	PC Break, Dual Vcc IO, IEB	PLBG0176GA-A
	HD64F2551FC26DV	384	24	3.0	5.5	26	3.0	5.5	Y	4	6	2	-	-	16	2	5	-	Y	2	Y	9	120	Y	Y		PRQP0144KB-A
	HD64F2552BR26DV	512	32	3.0	5.5	26	3.0	5.5	Y	4	6	2	-	-	16	2	5	-	Y	2	Y	9	120	Y	Y		PLBG0176GA-A
	HD64F2552FC26DV	512	32	3.0	5.5	26	3.0	5.5	Y	4	6	2	-	-	16	2	5	-	Y	2	Y	9	120	Y	Y		PRQP0144KB-A
H8S/2556	HD64F2556FC20DV	512	32	3.0	5.5	20	3.0	5.5	Y	4	6	2	-	-	16	2	5	-	Y	2	Y	9	120	Y	Y	PC Break, Dual Vcc IO, CAN	PRQP0144KB-A

Notes:

1. Y = Yes, includes 32kHz crystal oscillator circuitry.
2. This is the sum of the I/O pins + input-only + output-only.
3. Please visit Renesas website for full part number, specification, and availability of extended temperature parts.
4. This voltage supply is specific to some of the GPIO pins and independent of Vcc.

H8S/2600 Series Line-up

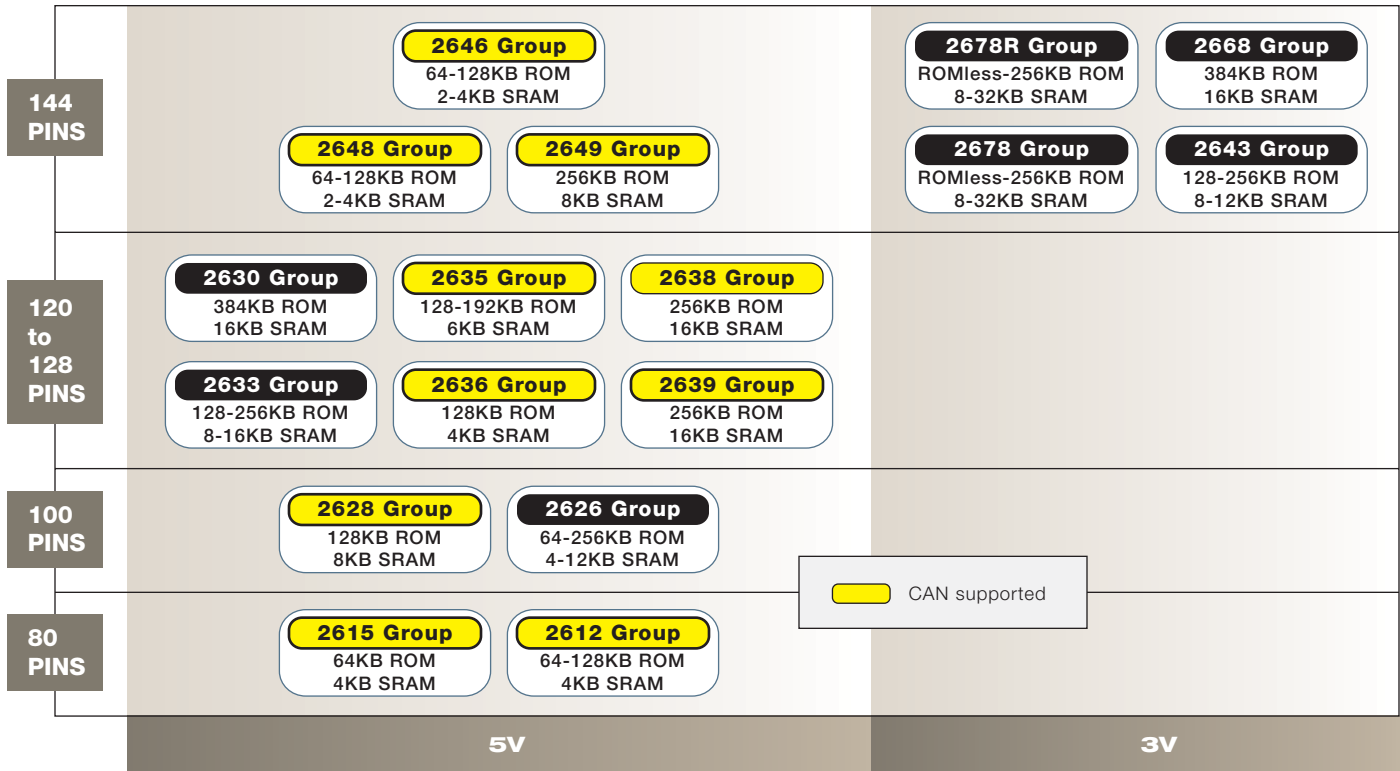

■ Features

- Up to 33MHz, low-power, 16-bit static CPU and hardware MAC
- 6 power-down modes for reducing power consumption
- 32kHz sub-clock oscillator circuit (some devices)
- Built-in Data Transfer Controller (DTC) with maximum of 85 channels
- Built-in DMA controller (DMAC) with maximum of 4 channels
- Up to 2-channel Controller Area Network (CAN v2.0) controller
- Supports Smart Card interface conforming to ISO/IEC 7816-3
- 16-bit motor-control PWM
- 2-channel on-chip PC Break controller for self-monitoring debugger
- Built-in Bus Controller (BSC) with arbitration bus to manage basic bus or burst-ROM interface
- Built-in SDRAM interface (H8S/2674R only)

■ Applications

Automotive: Airbag controllers, radar-collision avoidance systems, body ride/handling control systems, tire pressure monitors, electronic power-steering systems

Industrial: Pump controls, test-fixture controllers, pump units, thermal point controllers, siren controllers

Medical: Wireless base stations, fiber controllers for cable TV, network system controllers

H8S/2633 Series Block Diagram

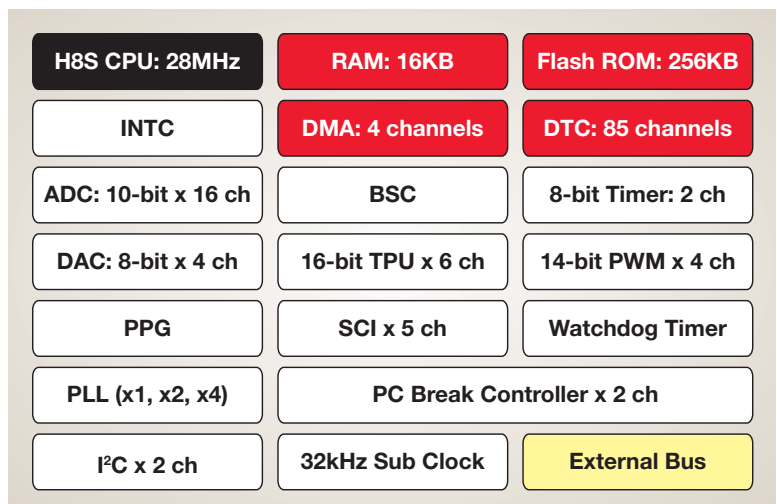

H8S/2600 Series Selector Guide

Group	Catalog Part Number	Flash (Kbytes)	Mask ROM Options (Kbytes)	RAM (Kbytes)	Vcc Min	Vcc Max	Max MHz @ Vcc Max	VccO Min (See Note 5)	VccO Max (See Note 5)	32 kHz Sub Clock (See Note 1)	Timers				Analog		Serial I/F			DMA Channels	External Interrupts	GPIO [See Note 2] (High Current) [See Note 3]	External Data Bus	Extended Temperature (See Note 4)	Special Features	Package Code					
											8-bit Timers	16-bit Timers	Watchdog Timers	Waveform Generator (PPG)	Motor Control PWM Timer	14-bit PWM D/A	A/D 10-bit Resolution	D/A 8-bit Resolution	Serial (Sync/Async)								IrDA	Samsrt Card Interface	I ² C	CAN	
H8S/2612	HD64F2612FA20V	128	Y	4	4.5	5.5	20	-	-	-	-	6	1	8	MMT	-	12	-	3	-	Y	-	1	Y	-	7	56 (0)	-	Y	PC Break, MMT	PRQP0080JD-A
H8S/2615	HD64F2615FA24V	64	Y	4	4.5	5.5	24	-	-	DIV	-	6	2	-	-	-	16	-	3	-	Y	-	1	-	-	7	56 (0)	-	Y	-	PRQP0080JD-A
H8S/2626	HD64F2623FA20JV	256	Y	12	4.5	5.5	20	-	-	-	-	6	1	8	-	-	16	-	3	-	Y	-	1	Y	-	7	70 (0)	Y	Y	2-ch PC Break	PRQP0100KA-A
	HD64F2623FA20V	256	Y	12	4.5	5.5	20	-	-	-	-	6	1	8	-	-	16	-	3	-	Y	-	1	Y	-	7	70 (0)	Y	Y		PRQP0100KA-A
	HD64F2626FA20JV	256	Y	12	4.5	5.5	20	-	-	Y	-	6	2	8	-	-	16	2	3	-	Y	-	1	Y	-	7	68 (0)	Y	Y		PRQP0100KA-A
	HD64F2626FA20V	256	Y	12	4.5	5.5	20	-	-	Y	-	6	2	8	-	-	16	2	3	-	Y	-	1	Y	-	7	68 (0)	Y	Y		PRQP0100KA-A
H8S/2628	HD64F2628FA24V	128	Y	8	4.5	5.5	24	-	-	-	4	6	1	8	-	-	16	-	2	-	Y	-	1	Y	-	7	76 (0)	-	Y	PC Break, 2 ch SSU	PRQP0100KB-A
H8S/2630	HD64F2630F20V	384	Y	16	4.5	5.5	20	-	-	-	-	6	2	8	1	-	12	2	3	-	Y	-	2	Y	-	7	84 (16)	Y	Y	15mA IO, PC Break	PRQP0128KB-A
	HD64F2630UF20V	384	Y	16	4.5	5.5	20	-	-	Y	-	6	2	8	1	-	12	2	3	-	Y	-	2	Y	-	7	84 (16)	Y	Y		PRQP0128KB-A
	HD64F2630WF20V	384	Y	16	4.5	5.5	20	-	-	Y	-	6	2	8	1	-	12	2	3	-	Y	2	2	Y	-	7	84 (16)	Y	Y		PRQP0128KB-A
H8S/2633	HD64F2633F16V	256	Y	16	3.0	3.6	16	3.0	5.5	Y	4	6	2	8	-	4	16	4	5	Y	Y	2	-	Y	4	9	89 (0)	Y	Y	PC Break, DRAMC	PRQP0128KB-A
	HD64F2633RF28V	256	-	16	4.5	5.5	28	4.5	5.5	Y	4	6	2	8	-	4	16	4	5	Y	Y	2	-	Y	4	9	89 (0)	Y	Y		PRQP0128KB-A
	HD64F2633RTE28V	256	-	16	4.5	5.5	28	4.5	5.5	Y	4	6	2	8	-	4	16	4	5	Y	Y	2	-	Y	4	9	89 (0)	Y	-		PTQP0120LA-A
	HD64F2633TE16V	256	Y	16	3.0	3.6	16	3.0	5.5	Y	4	6	2	8	-	4	16	4	5	Y	Y	2	-	Y	4	9	89 (0)	Y	Y		PTQP0120LA-A
H8S/2636	HD64F2636F20V	128	Y	4	4.5	5.5	20	-	-	-	-	6	2	8	1	-	12	2	3	-	Y	-	2	Y	-	7	84 (16)	Y	Y	15mA IO, PC Break	PRQP0128KB-A
	HD64F2636UF20V	128	Y	4	4.5	5.5	20	-	-	Y	-	6	2	8	1	-	12	2	3	-	Y	-	2	Y	-	7	84 (16)	Y	Y		PRQP0128KB-A
H8S/2638	HD64F2638F20V	256	Y	16	4.5	5.5	20	-	-	-	-	6	2	8	1	-	12	2	3	-	Y	-	2	Y	-	7	84 (16)	Y	Y	15mA IO, PC Break	PRQP0128KB-A
	HD64F2638UF20V	256	Y	16	4.5	5.5	20	-	-	Y	-	6	2	8	1	-	12	2	3	-	Y	-	2	Y	-	7	84 (16)	Y	Y		PRQP0128KB-A
	HD64F2638WF20V	256	Y	16	4.5	5.5	20	-	-	Y	-	6	2	8	1	-	12	2	3	-	Y	2	2	Y	-	7	84 (16)	Y	Y		PRQP0128KB-A
H8S/2639	HD64F2639UF20V	256	Y	16	4.5	5.5	20	-	-	DIV	-	6	2	8	1	-	12	2	3	-	Y	-	2	Y	-	7	84 (16)	Y	Y	15mA IO, PC Break	PRQP0128KB-A
	HD64F2639WF20V	256	Y	16	4.5	5.5	20	-	-	DIV	-	6	2	8	1	-	12	2	3	-	Y	2	2	Y	-	7	84 (16)	Y	Y		PRQP0128KB-A
H8S/2643	HD64F2643FC16V	256	Y	16	3.0	3.6	16	3.0	5.5	Y	4	6	2	16	-	-	16	4	5	Y	Y	2	-	Y	4	9	111 (0)	Y	Y	PC Break, DRAMC	PRQP0144KB-A
	HD64F2643FC25V	256	Y	16	3.0	3.6	25	4.5	5.5	Y	4	6	2	16	-	-	16	4	5	Y	Y	2	-	Y	4	9	111 (0)	Y	Y		PRQP0144KB-A
H8S/2648	HD64F2646RFC20JV	128	Y	4	4.5	5.5	20	-	-	Y	-	6	2	8	1	-	12	-	2	-	Y	-	1	Y	-	7	108 (16)	Y	Y	15mA IO, PC Break, 24x4 LCDC	PRQP0144KB-A
	HD64F2646RFC20V	128	Y	4	4.5	5.5	20	-	-	Y	-	6	2	8	1	-	12	-	2	-	Y	-	1	Y	-	7	108 (16)	Y	Y		PRQP0144KB-A
	HD64F2648RFC20JV	128	Y	4	4.5	5.5	20	-	-	Y	-	6	2	8	1	-	12	-	3	-	Y	-	1	Y	-	7	108 (16)	Y	Y	15mA IO, PC Break, 40x4 LCDC	PRQP0144KB-A
	HD64F2648RFC20V	128	Y	4	4.5	5.5	20	-	-	Y	-	6	2	8	1	-	12	-	3	-	Y	-	1	Y	-	7	108 (16)	Y	Y		PRQP0144KB-A
H8S/2649	HD64F2649FC20JV	256	Y	6	4.5	5.5	20	-	-	Y	-	6	2	8	1	-	16	-	4	-	Y	-	2	Y	-	7	113 (0)	Y	Y	PC Break, 40x4 LCDC	PRQP0144KA-A
H8S/2668	HD64F2667VFQ33V	384	-	16	3.0	3.6	33	-	-	-	2	6	1	8	-	-	12	4	3	Y	Y	-	-	Y	-	9	115 (0)	Y	Y	HSS	PLQP0144KC-A
H8S/2678	HD6412670VFC33V	-	-	8	3.0	3.6	33	-	-	-	2	6	1	16	-	-	12	4	3	Y	Y	-	-	Y	8	17	115 (0)	Y	Y	4 ch EXDMAC, DRAMC	PRQP0144KA-A
	HD6412674RVFQ33V	-	-	32	3.0	3.6	33	-	-	-	2	6	1	16	-	-	12	4	3	Y	Y	-	-	Y	8	17	115 (0)	Y	Y	SDRAM, 4 ch EXDMAC, HSS	PLQP0144KC-A
	HD64F2676VFC33V	256	Y	8	3.0	3.6	33	-	-	-	2	6	1	16	-	-	12	4	3	Y	Y	-	-	Y	8	17	115 (0)	Y	Y	4 ch EXDMAC, DRAMC	PRQP0144KA-A

Notes:

- KEY: Y = Yes, includes 32kHz crystal oscillator circuitry; "DIV" = Main clock is divided down for sub clock mode.
- This is the sum of the I/O pins + input-only + output-only.
- High-current is defined as greater than or equal to 10mA for a signal being driven low. This pin count is included in the GPIO total.
- Please visit Renesas website for full part number, specification, and availability of extended temperature parts.
- This voltage supply is specific to some of the GPIO pins, and independent of Vcc.

H8SX Series Line-up

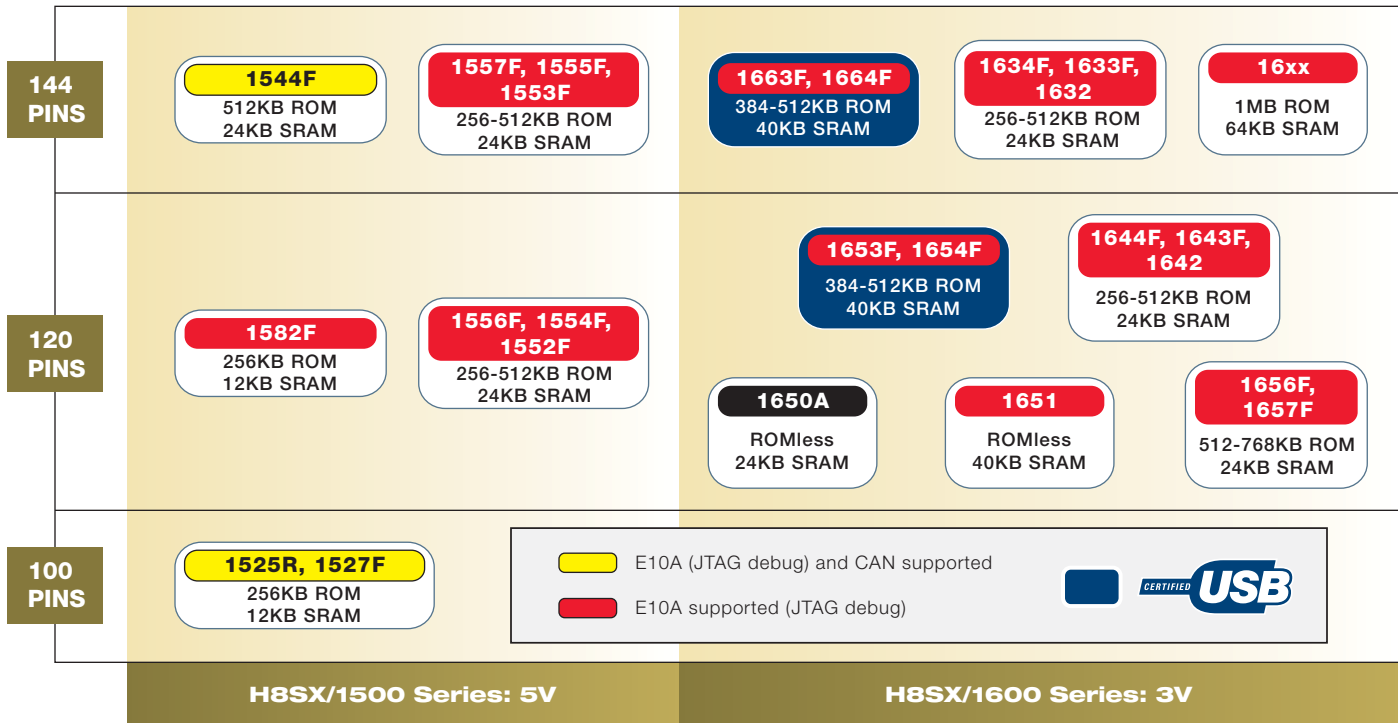

Features

- Up to 50MHz, low-power, 32-bit static CISC CPU
- 6 power-down modes for reducing power consumption
- 32kHz sub-clock oscillator circuit (some devices)
- Highly reliable built-in single-supply flash: 256KB to 1MB
- On-chip high-speed SRAM: 12KB to 64KB
- Built-in Data Transfer Controller (DTC) with maximum of 85 channels
- Built-in DMA controller (DMAC) with maximum of 4 channels
- Bus-powered/self-powered on-chip USB (v2.0 full speed) core for easy serial connectivity
- Up to 2-channel Controller Area Network (CAN v2.0) controller
- Supports Smart Card interface conforming to ISO/IEC 7816-3
- Built-in Bus Controller (BSC) with arbitration bus to manage basic bus or burst-ROM interface
- Built-in SDRAM interface (H8SX/1664 only)

Applications

- Automotive:** Airbag controllers, power steering systems
- Industrial:** Control Modules (LCD, USB), Bar Code scanners, Electronic Point of Sale
- Consumer:** Fitness Machines, Thermostat, Handheld Devices (Bluetooth), Printers, USB Dongles

H8SX/1664 Series Block Diagram

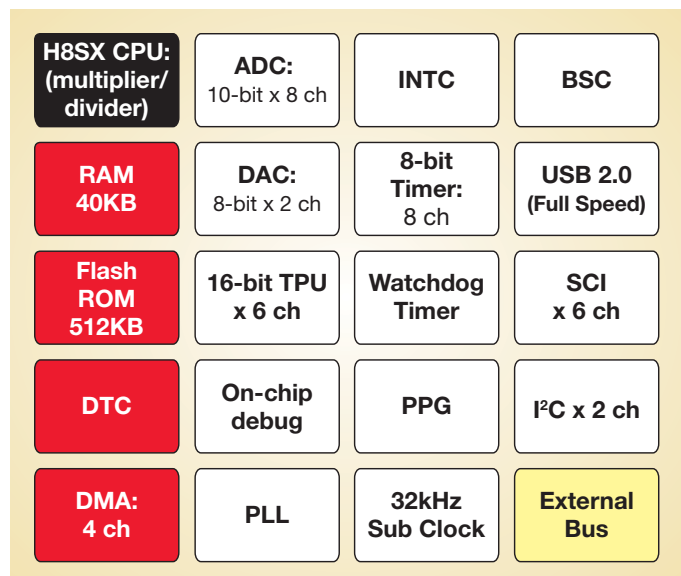

H8SX Series Selector Guide

Group	Part Number	Flash (Kbytes)	RAM (Kbytes)	Vcc Min	Vcc Max	Max. MHz @ Vcc Max	32kHz Sub Clock (See Note 1)				Timers		Analog		Serial				DTC	DMA Channels	External Interrupts	GPIO (See Note 2) (High Current) (See Note 3)	External Data Bus	Extended Temp. (See Note 4)	Special Features	Package Code	
							8-bit Timers	16-bit Timers	Watchdog Timers	Waveform Generator (PPG)	A/D 10-bit Resolution	D/A 8-bit Resolution	Serial (Sync/Async)	SSU (SPI compatible)	IrDA	Smart Card Interface	I ² C	CAN									
H8SX/1525	R5F61525N40FP	256	12	4.5	5.5	40	-	-	6	1	-	16	-	2	3	-	Y	-	1	-	4	16	82 (0)	-	Y	-	PRQP0100KB-A
H8SX/1527	R5F61527N40FP	256	12	4.5	5.5	40	-	-	12	1	8	16	-	2	3	-	Y	-	1	-	4	16	82 (0)	-	Y	-	PRQP0100KB-A
H8SX/1552 ⁵	R5F61552N40FPV	256	24	4.5	5.5	40	-	4	12	1	-	16	2	6	-	-	Y	2	-	Y	4	16	82 (0)	Y	Y	-	PLQP0120LA-A
H8SX/1553 ⁵	R5F61553N40FPV	256	24	4.5	5.5	40	-	4	6	1	-	16	2	6	-	-	Y	2	-	Y	4	16	82 (0)	Y	Y	-	PRQP0144KB-A
H8SX/1554 ⁵	R5F61554N40FPV	384	24	4.5	5.5	40	-	4	12	1	-	16	2	6	-	-	Y	2	-	Y	4	16	82 (0)	Y	Y	-	PLQP0120LA-A
H8SX/1555 ⁵	R5F61555N40FPV	384	24	4.5	5.5	40	-	4	12	1	-	16	2	6	-	-	Y	2	-	Y	4	16	82 (0)	Y	Y	-	PRQP0144KB-A
H8SX/1556 ⁵	R5F61556N40FPV	512	24	4.5	5.5	40	-	4	12	1	-	16	2	6	-	-	Y	2	-	Y	4	16	82 (0)	Y	Y	-	PLQP0120LA-A
H8SX/1557 ⁵	R5F61557N40FPV	512	24	4.5	5.5	40	-	4	12	1	-	16	2	6	-	-	Y	2	-	Y	4	16	82 (0)	Y	Y	-	PRQP0144KB-A
H8SX/1582	R5F61582N48FPV	256	12	4.5	5.5	48	-	-	12	1	8	16	-	2	3	-	Y	-	-	Y	4	17	99 (0)	-	Y	-	PLQP0120LA-A
H8SX/1632 ⁵	R5F61632N50FPV	256	24	3.0	3.6	50	-	4	12	1	-	16	2	6	-	-	Y	2	-	Y	4	16	82 (0)	Y	Y	-	PRQP0144KB-A
H8SX/1633 ⁵	R5F61633N50FPV	384	24	3.0	3.6	50	-	4	12	1	-	16	2	6	-	-	Y	2	-	Y	4	16	82 (0)	Y	Y	-	PRQP0144KB-A
H8SX/1634 ⁵	R5F61634N50FPV	512	24	3.0	3.6	50	-	4	12	1	-	16	2	6	-	-	Y	2	-	Y	4	16	82 (0)	Y	Y	-	PRQP0144KB-A
H8SX/1642 ⁵	R5F61642N50FPV	256	24	3.0	3.6	50	-	4	12	1	-	16	2	6	-	-	Y	2	-	Y	4	16	82 (0)	Y	Y	-	PLQP0120LA-A
H8SX/1643 ⁵	R5F61643N50FPV	384	24	3.0	3.6	50	-	4	12	1	-	16	2	6	-	-	Y	2	-	Y	4	16	82 (0)	Y	Y	-	PLQP0120LA-A
H8SX/1644 ⁵	R5F61644N50FPV	512	24	3.0	3.6	50	-	4	12	1	-	16	2	6	-	-	Y	2	-	Y	4	16	82 (0)	Y	Y	-	PLQP0120LA-A
H8SX/1650	R5S61650N35FTV	0	24	3.0	3.6	35	-	4	6	1	16	8	2	4	-	Y	Y	-	-	Y	-	13	90 (8)	Y	-	HSS	PTQP0120LA-A
H8SX/1651	R5S61651N50FPV	0	40	3.0	3.6	35	-	4	6	1	16	8	2	4	-	Y	Y	-	-	Y	-	13	90 (8)	Y	-	HSS	PLQP0120LA-A
H8SX/1653	R5F61653N50FTV	384	40	3.0	3.6	50	-	4	6	1	8	8	2	6	-	Y	Y	2	-	Y	4	13	84 (125)	Y	-	CRC, HSS, USB	PTQP0120LA-A
H8SX/1654	R5F61654N50FTV	512	40	3.0	3.6	50	-	4	6	1	8	8	2	6	-	Y	Y	2	-	Y	4	13	84 (125)	Y	-	CRC, HSS, USB	PTQP0120LA-A
H8SX/1657	R5F61657BN35FTV	768	24	3.0	3.6	35	-	4	6	1	16	8	2	4	-	Y	Y	-	-	Y	4	13	90 (8)	Y	-	HSS	PTQP0120LA-A
	R5F61657N35FTV	768	24	3.0	3.6	35	-	4	6	1	16	8	2	4	-	Y	Y	-	-	Y	4	13	90 (8)	Y	-		
H8SX/1663	R5F61663N50FTV	384	40	3.0	3.6	50	Y	4	6	1	8	8	2	6	-	Y	Y	2	-	Y	4	13	101 (125)	Y	-	CRC, HSS, USB	PRQP0144KB-A
H8SX/1664	R5F61664N50FTV	512	40	3.0	3.6	50	Y	4	6	1	8	8	2	6	-	Y	Y	2	-	Y	4	13	101 (125)	Y	-	CRC, HSS, USB	PRQP0144KB-A

Notes:

1. Y = Yes, includes 32kHz crystal oscillator circuitry
2. This is the sum of the I/O pins + input-only + output-only.
3. High-current is defined as greater than or equal to 10mA for a signal being driven low. This pin count is included in the GPIO total.
4. Please visit Renesas website for full part number, specification, and availability of extended temperature parts.
5. The specification for this device is subject to change.

Great Performance for System Connectivity!

Microcontrollers in the H8SX series have high-capacity SRAM, high-performance CPUs, and packages with many pins, making them ideal for complex system hub operation.

Wide Address and Data buses allow connection to multiple external blocks for high-speed data transfers.

Large number of GPIOs and an extensive array of serial interface functions allow connections to any type of external device or function.

Advanced DMA engines within H8SX series can move data between external devices in parallel with on-chip transfers for higher system performance.

High-performance H8SX CPU Core	➔	32-bit data and address bus, 1-cycle access 50MHz performance HW 32-bit multiplier/divider	➔	High Performance — 50MIPS Single-cycle 16-bit x 16-bit
Improved system throughput	➔	Add specific registers: VBR (Vector Base Register) SBR (Short-address Base Register) Auto Conversion: Big and Little Endian	➔	High response for INT at double speed High-speed access to external I/O: 1.3 times High-speed network access (Non-overhead, penalty)
Compatibility	➔	Enhanced H8 and H8S instruction set and peripheral functions		

■ Application Example 1: Thermostat Solution Using H8/38076R

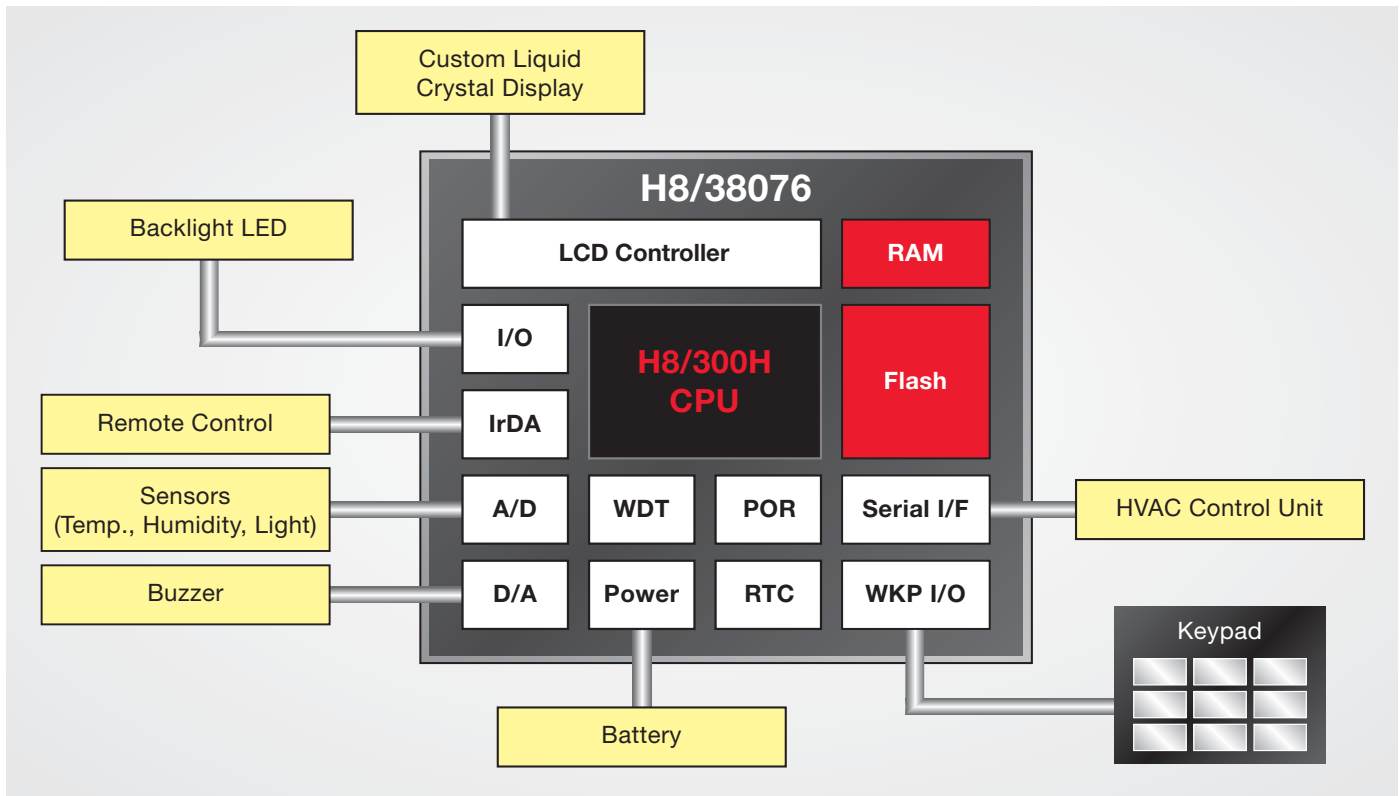

■ Application Example 2: Garage Door Controller using H8/36077

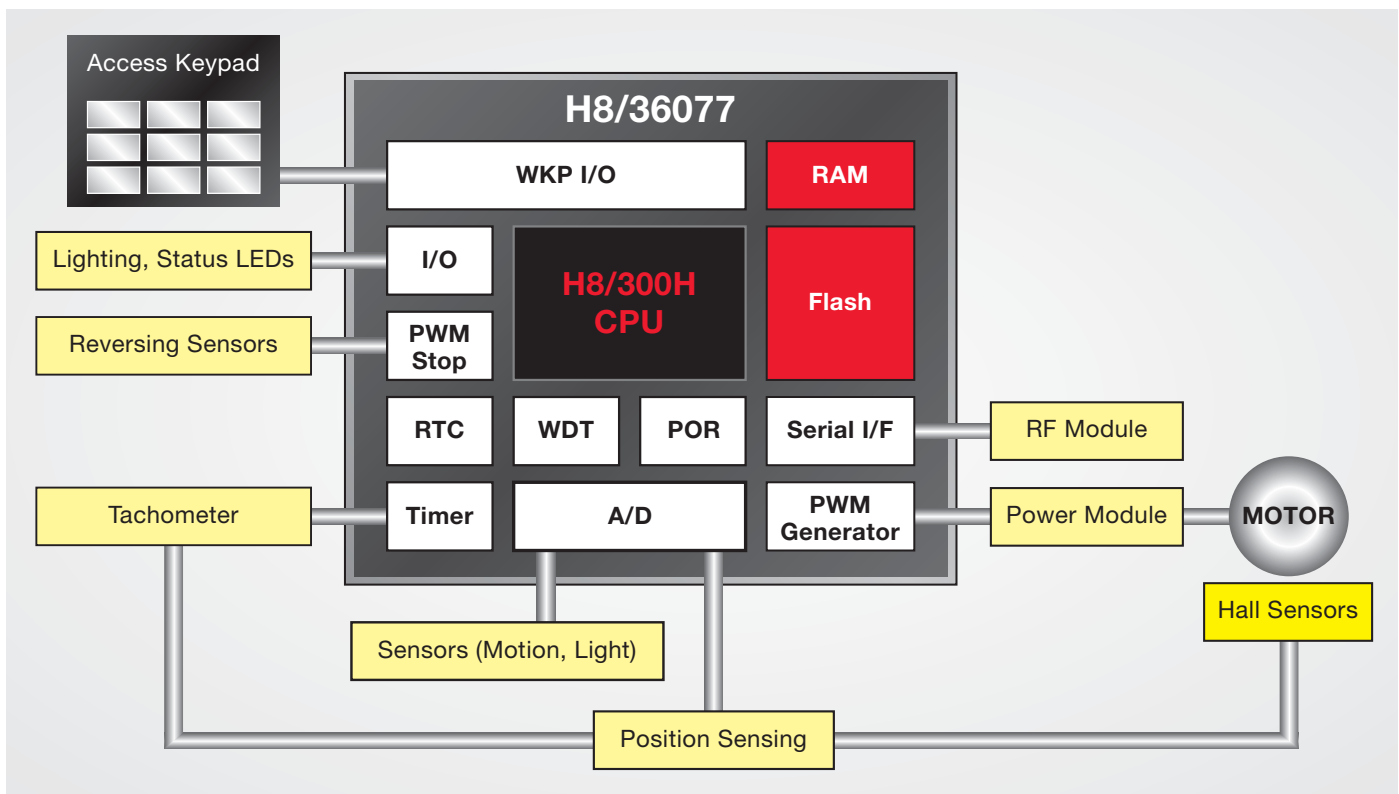

■ Application Example 3: Intelligent Platform Management Interface (IPMI) Solution Using H8S/2166

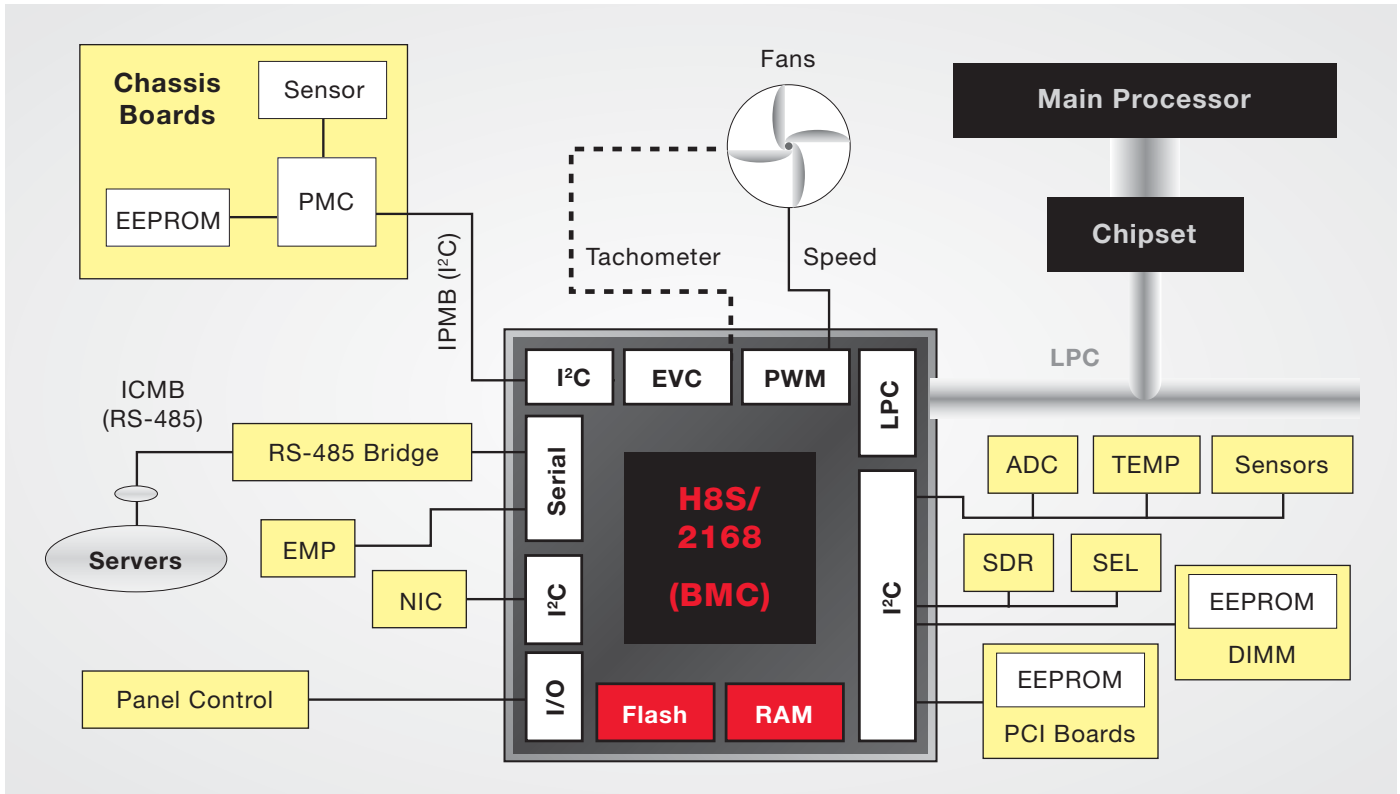

■ Application Example 4: ePOS Solution Using H8SX/1653

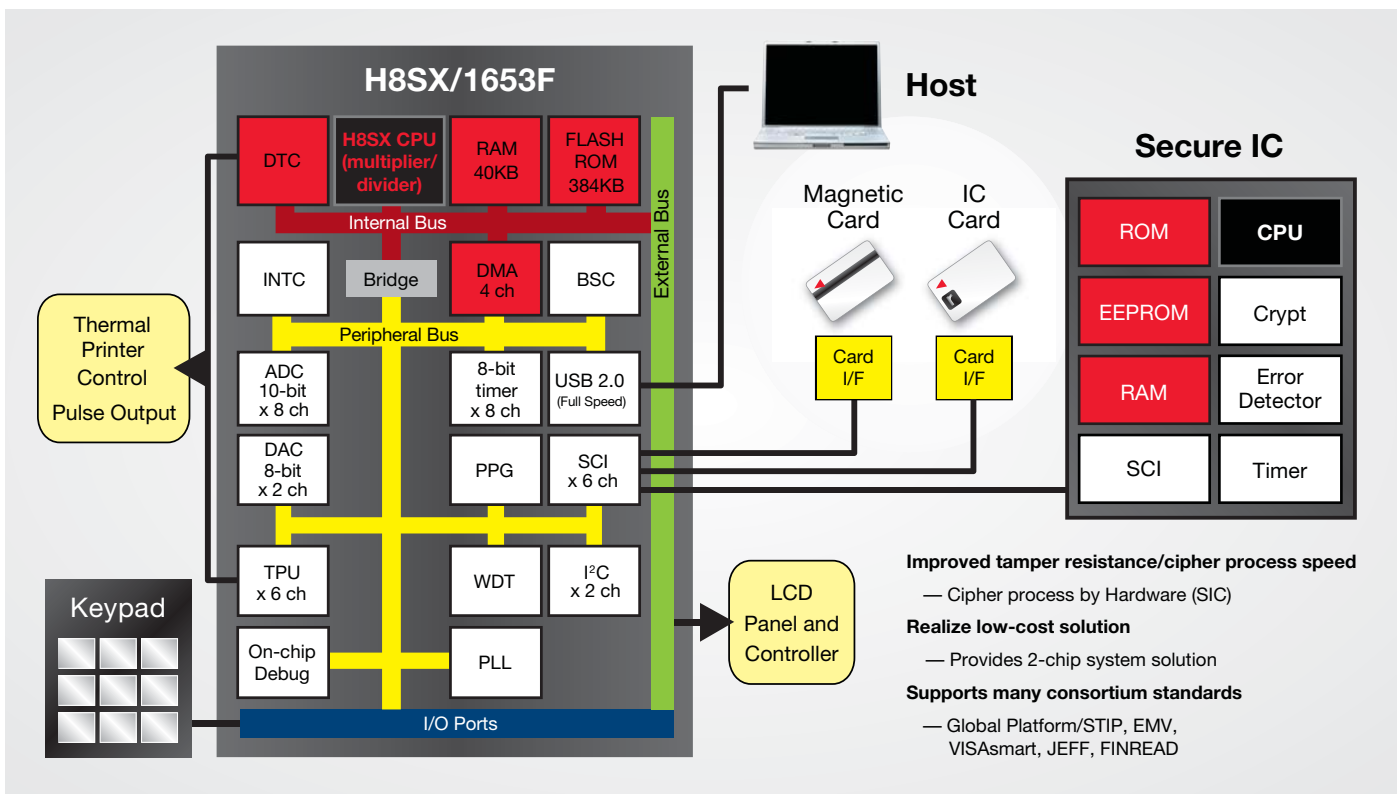

■ Appendix C-1: Catalog Part Number Decoders (1 of 2)

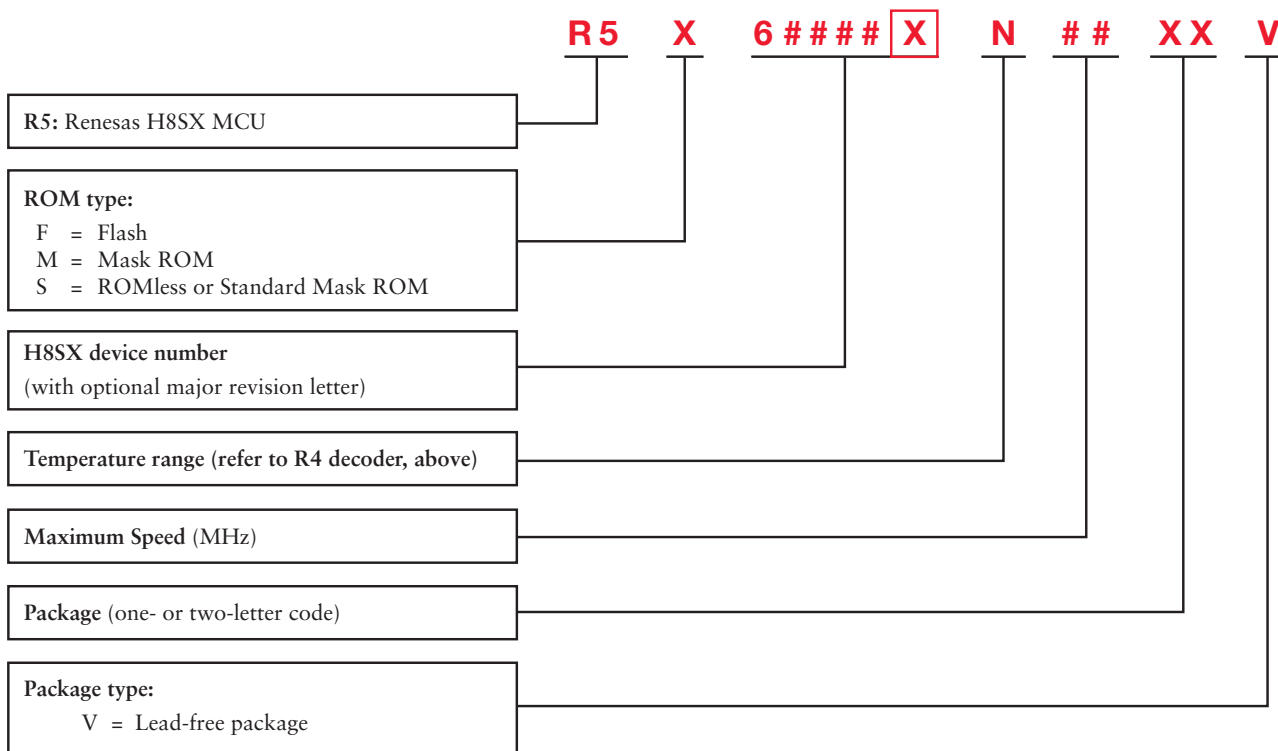
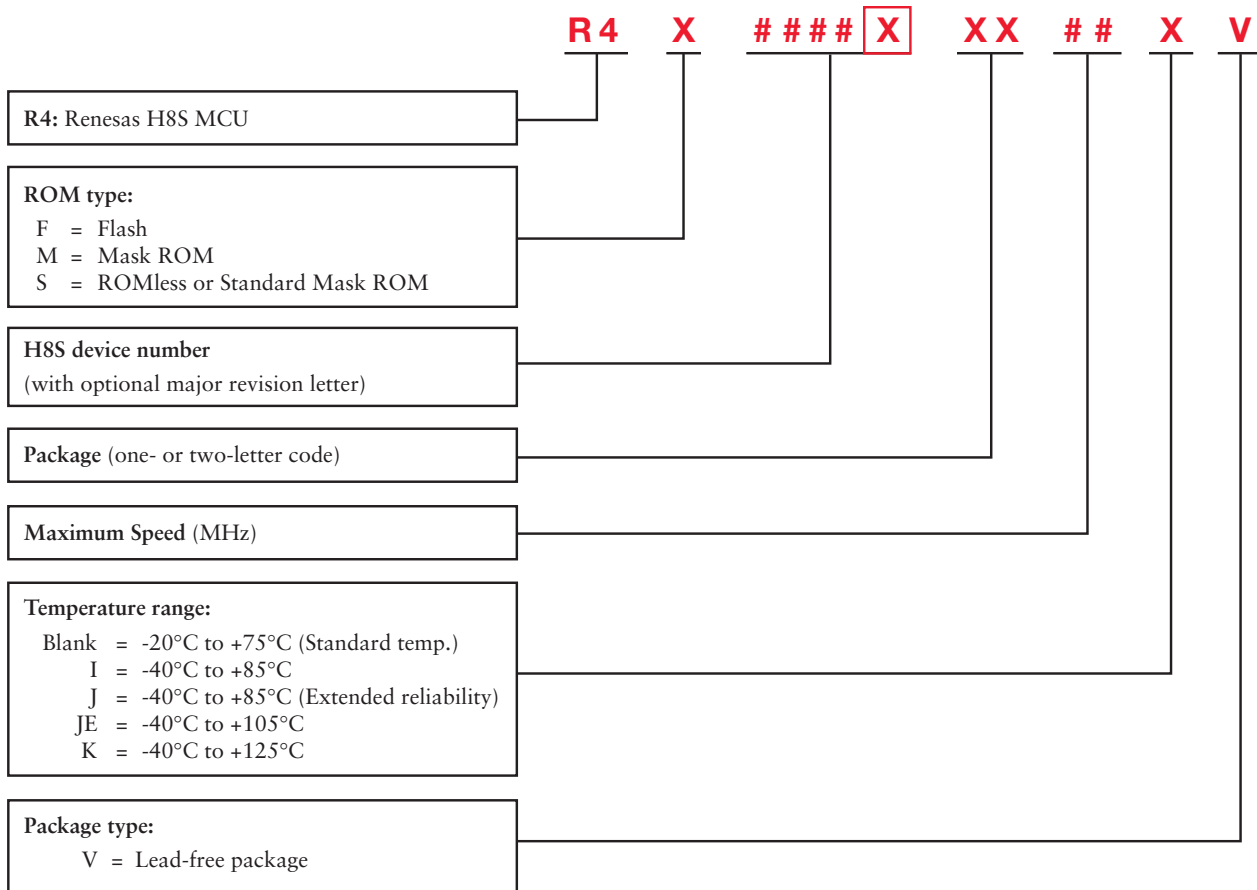

Appendices

■ Appendix C-2: Catalog Part Number Decoders (2 of 2)

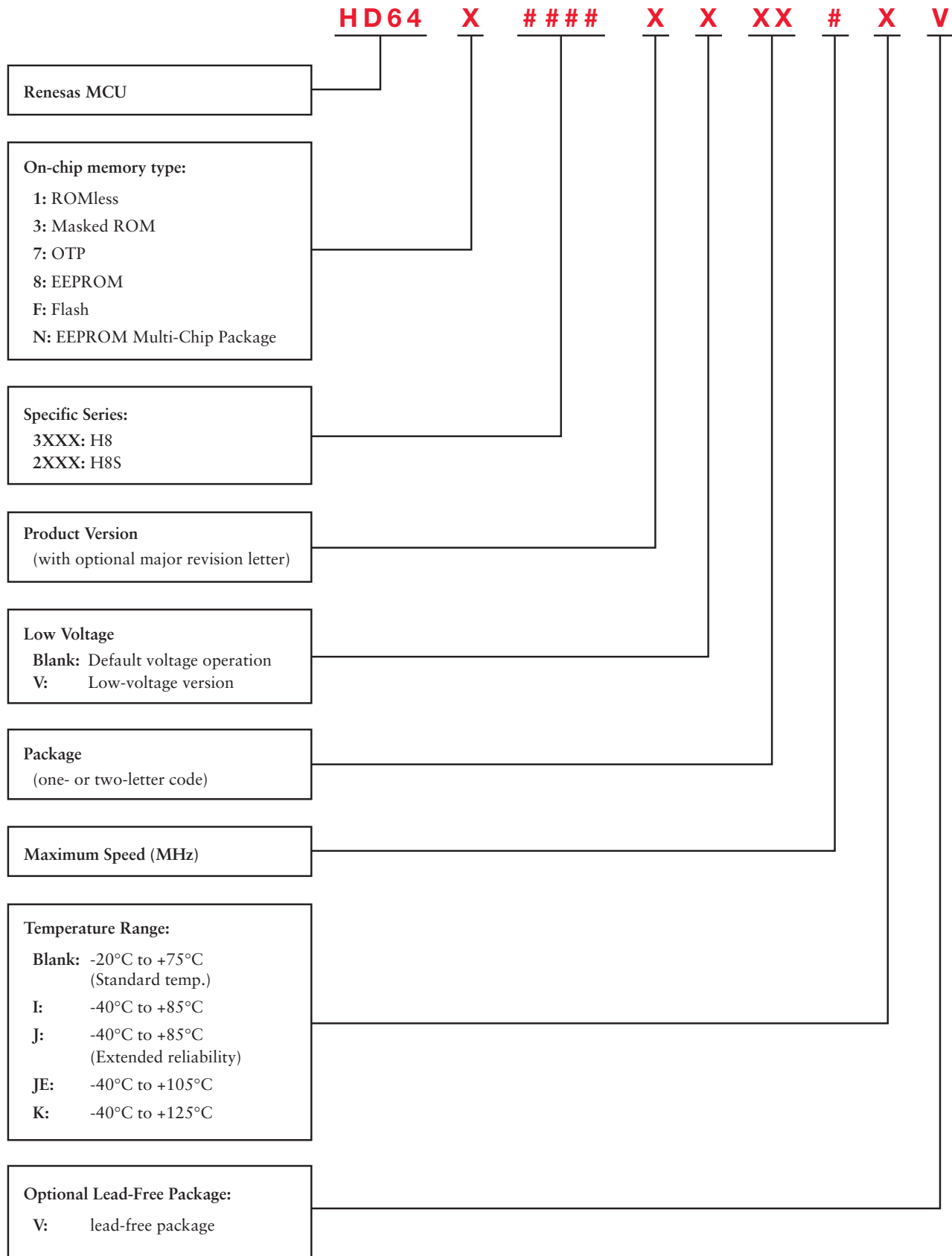

■ Appendix A: Abbreviations

15mA IO	Contains I/O pins that source/sink 15mA
5V IO	Contains I/O pins which are 5V tolerant
ADC	Analog-to-Digital Converter
AEC	Asynchronous Event Counter
Boot from USB	Flash programmable via USB port
BSC	External Bus Controller
BSCAN	Boundary Scan
BT	On-chip Memory Bus Trace
CAN	Controller Area Network
CRC	Cyclic Redundancy Check Generator
CTB	Clock Time Base
DAC	Digital to Analog Converter
DMAC	Direct Memory Access Controller
DMC	Duty Measurement Circuit
DRAMC	DRAM Controller
DTC	Data Transfer Controller
DTMF	Telephone Tone Generator
Dual Vcc IO	Two Vcc domains for I/O Ports
ECF	Event Counter Function
EXDMAC	Enhanced DMA Controller
HSS	High-Speed Serial Communications
I ² C	Inter IC Bus
IC	Input Capture

IC/OC	Input Capture/Output Compare
IrDA	Infrared Serial Port
ITO	Interval Timer Operation
KBD	Keyboard Scan Function
LCDC	LCD Controller/Driver
LPC	Low-Pin-Count Interface Bus
LVD	Low-Voltage Detect
MMT	Motor Management Timer
OCD	On-Chip Debug
OCO	On-Chip Oscillator
PC Break	PC Break Controller
POR	Power-On Reset
PS2	PS2 Interface
PWM	Pulse Width Modulation
ROP	Read-Out Protection
RTC	Real-Time Clock
SDRAM	SDRAM Bus Controller
SPI	Serial Peripheral Interface
SSU	Synchronous Serial Unit (SPI compatible)
TMC	Timer Connection Circuit
USB	Universal Serial Bus Interface
USBH	Universal Serial Bus Interface – High Speed
X-Bus	ISA Bus Interface

■ Appendix B: Package Specifications

Type	Renesas Code	Previous Code	Pin Count	Nominal Body Dimensions (mm)	Lead Pitch (mm)	Thickness (mm)	
QFP	Quad Flat Package	PRQP0064GB-A	FP-64A	64	14 x 14	0.8	3.05
		PRQP0080GD-B	FP-80B	80	20 x 20	0.8	3.10
		PRQP0080JB-A	FP-80Q	80	14 x 14	0.65	3.05
		PRQP0100JE-B	FP-100A	100	14 x 20	0.65	3.10
		PRQP0100KA-A	FP-100B	100	14 x 14	0.5	3.05
		PRQP0100KB-A	FP-100M	100	14 x 14	0.5	3.05
		PRQP0128KB-A	FP-128B	128	14 x 20	0.5	3.15
		PRQP0144KA-A	FP-144G	144	20 x 20	0.5	3.05
		PRQP0144KB-A	FP-144J	144	20 x 20	0.5	3.05
		LQFP	Low-profile QFP	PLQP0032GC-A	FP-32A	32	7 x 7
PLQP0048JA-A	FP-48F			48	10 x 10	0.65	1.70
PLQP0048KC-A	FP-48B			48	7 x 7	0.5	1.70
PLQP0064KB-A	FP-64K			64	10 x 10	0.5	1.70
PLQP0064KC-A	FP-64E			64	10 x 10	0.5	1.70
PLQP0100KB-A	FP-100U			100	14 x 14	0.5	1.70
PLQP0120LA-A	FP-120B			120	14 x 14	0.4	1.70
PLQP0144KC-A	FP-144H			144	20 x 20	0.5	1.70
TQFP	Thin QFP	PTQP0080KC-A	TFP-80C	80	12 x 12	0.5	1.20
		PTQP0100KA-A	TFP-100B	100	14 x 14	0.5	1.20
		PTQP0100LC-A	TFP-100G	100	12 x 12	0.4	1.20
		PTQP0120LA-A	TFP-120	120	14 x 14	0.4	1.20
		PTQP0144LC-A	TFP-144	144	16 x 16	0.4	1.20
LFBGA	LF Ball Grid Array	PLBG0112GA-A	BP-112	112	10 x 10	0.8	1.40
		PLBG0176GA-A	BP-176	176	13 x 13	0.8	1.40
TFBGA	Thin Fine-Pitch BGA	TTBG0112GA-A	TBP-112A	112	10 x 10	0.8	1.20
SDIP	Shrink Dual-Inline Package	PRDP0032BB-A	DP-32S	32	28 x 8.9	1.78	5.08
		PRDP0064BB-A	DP-64S	64	57.6 x 17	1.78	5.08
TFLGA	Thin Fine-Pitch Land Grid Array	PTLG0085JA-A	TLP-85V	85	7 x 7	0.65	1.20
		PTLG0113JA-A	TLP-113V	113	8 x 8	0.65	1.20
		PTLG0145JB-A	TLP-145V	145	9 x 9	0.65	1.20
QFN	Quad Flat Non-lead Pkg.	PVQN0048KA-A	TNP-48	48	7 x 7	0.5	1.00
VQFN	Very Small QFN	PVQN0032KA-A	TNP-32	32	5 x 6	0.5	0.95
SOP	Small-Outline Package	PRSP0032DC-A	FP-32D	32	11.3 x 20.45	1.27	3.00

Converting Catalog Part Numbers to Orderable Part Numbers

To order Renesas devices, the **Catalog Part Numbers** listed in this catalog must be converted to **Orderable Part Numbers**. Here's how:

1

From the Renesas web site, in the Part Number search, enter the "post-slash" Group Number (example: 2140B for H8S/2140B group)

2

Locate the required Catalog Part Number and click on the Buy Now button

3

Locate the Orderable Part Number in the table

The screenshot shows the Renesas website interface. In the search bar, '2140B' is entered. The search results table lists several products, with 'HD64F2140BTE' highlighted. The 'Buy Now' button is clicked for this product. The resulting page shows the 'Purchasing Information' for 'HD64F2140BTE', including a table of 'Orderable Parts Number (s)' with 'DF2140BVTE10V' listed.

Orderable Parts Number (s)	Package Description	Compliance (RoHS compliant)	1000 Piece Budgetary Price	Request Pricing	Distributor Stock	Distributor Name	Distributor Region	Last Updated Date	Distributor Purchase
DF2140BVTE10V	TFP-100B								

Renesas Interactive — Your Online Environment for Semiconductor Device Research, Evaluation and Application

Renesas Interactive is a valuable FREE online evaluation service that lets you work at your own pace, whenever it is most convenient to do so.

- Take an online interactive training course and learn about the details of Renesas MCU product architectures and peripheral functions, as well as hardware and software development tools.

The screenshot shows the 'RENEASAS INTERACTIVE VirtualLab Desktop' interface. It features a sidebar with icons for 'Flash Programmer', 'IDE', 'Debugger', and 'Target Control'. The main window displays a virtual circuit board with various sensors and controls, including 'CDS Cell (Light Sensor)', 'Thermistor (Temperature)', and 'Power Control'.

- Access actual hardware, software and tools in the Virtual Lab Development Environment and take weeks off your MCU assessment, evaluation and setup process.

- Watch live or archived webcasts and find out about new Renesas technology, products and services.



www.renesasinteractive.com

Renesas Technology

www.america.renesas.com

© 2006 Renesas Technology America, Inc. Renesas Technology America, Inc. is a wholly owned subsidiary of Renesas Technology Corporation. H8 and the H8 logo are registered trademarks of Renesas Technology Corporation. All other trademarks are the property of their respective holders. The information supplied by Renesas Technology America, Inc. is believed to be accurate and reliable, but in no event shall Renesas Technology America, Inc. be liable for any damages whatsoever arising out of the use or inability to use the information or any errors that may appear in this publication. The information is provided as is without any warranties of any kind, either express or implied. Renesas Technology America, Inc. reserves the right, without notice, to make changes to the information or to the design and specifications of its hardware and/or software products. Products subject to availability. Printed in U.S.A.



Printed on Recycled Paper 0806/10K/VIP/PF/SP Order Number: REU01B0011-0101