

STM8L1526-EVAL evaluation board

Introduction

The STM8L1526-EVAL evaluation board is a complete demonstration and development platform for STMicroelectronics' STM8 core-based STM8L152C6 microcontroller which supports I2C, SPI, USART, 12-bit ADC, 12-bit DAC, LCD driver, 2 KB internal SRAM, 32 KB EEPROM and SWIM debugging.

The full range of hardware features on the board helps you evaluate all peripherals (motor control, USART, audio DAC, LCD, IR LED, IrDA, SPI Flash, MicroSD Card, temperature sensor and EEPROM... etc.) and develop your own applications. Extension headers facilitate easy connection of a daughterboard or wrapping board for specific applications.

An ST-LINK is integrated on the board as the embedded in-circuit debugger and programmer for the STM8 MCU.

Figure 1. STM8L1526-EVAL evaluation board



Contents

1	Features	4
1.1	Hardware	4
1.2	Demonstration software	4
1.3	Order code	4
2	Hardware layout and configuration	5
2.1	Power supply	8
2.2	Clock source	9
2.3	Reset source	10
2.4	LCD glass module	10
2.5	Audio	11
2.6	EEPROM	12
2.7	RS-232 and IrDA	12
2.8	Motor control	13
2.9	MicroSD Card	15
2.10	Analog input	15
2.11	Serial Flash	15
2.12	Temperature sensor	15
2.13	Development and debug support	16
2.14	Display and input devices	17
2.15	IDD measurement and comparator	18
2.16	Comparator	19
2.17	IR LED	20
3	Connectors	21
3.1	RS-232 connector CN1	21
3.2	Power connector CN2	21
3.3	TFT LCD connector CN3	21
3.4	Daughterboard extension connector CN4 and CN10	22
3.5	LCD glass connector CN5 and CN6	24
3.6	Motor control connector CN7	25

3.7	STice connector CN8	25
3.8	ST-LINK programming connector CN9	27
3.9	USB type B connector CN11	27
3.10	SWIM connector CN12 and CN16	27
3.11	Audio jack CN13	27
3.12	MicroSD connector CN14	28
3.13	BNC connector CN15	28
4	Schematics	29
	Appendix A STM8L1526-EVAL I/O assignment	43
	Revision history	45

1 Features

1.1 Hardware

- Three 5 V power supply options: power jack, ST-LINK USB connector or daughterboard
- Audio speaker and microphone connected to the DAC and ADC of the STM8L152C6
- 1 GByte SPI interface MicroSD Card
- 128 Mbit SPI serial Flash
- I2C compatible serial interface 64 KBit EEPROM and SMBusTemperature sensor
- RS-232 communication
- IrDA transceiver
- Inductor motor control connector
- SWIM debug support, ST-LINK embedded
- 122x32 dot matrix LCD connected to the SPI interface of the STM8L152C6
- Joystick with 4-direction control and selector
- Reset and User button
- 4 color LEDs and one bicolor LED
- MCU consumption measurement circuit
- LCD glass 28 x 4 segments (7 digits alpha numeric) connected to the LCD driver inside the STM8L152C6
- Extension connector for daughterboard or wrapping board
- MCU voltage choice 3.3 V or adjustable from 1.65 V to 3.6 V
- STice connector footprint
- Board RoHS compliant (lead free)

1.2 Demonstration software

Demonstration software is preloaded in the board's Flash memory for easy demonstration of device peripherals in stand-alone mode. For more information and to download the latest version available, please refer to STM8L1526-EVAL demonstration firmware available on web: www.st.com/mcu.

1.3 Order code

To order the STM8L152C6 evaluation board, use the order code STM8L1526-EVAL.

2 Hardware layout and configuration

The STM8L1526-EVAL evaluation board is designed around the STM8L1526C6T6 (48-pin LQFP package). The hardware block diagram *Figure 2* illustrates the connection between the STM8L1526C6 and the peripherals (LCD glass, dot matrix LCD, serial Flash, EEPROM, temperature sensor, USART, IrDA, audio, MicroSD Card, Motor control and embedded ST-LINK). *Figure 3* and *Figure 4* help you locate these features on the actual evaluation board.

Figure 2. Hardware block diagram

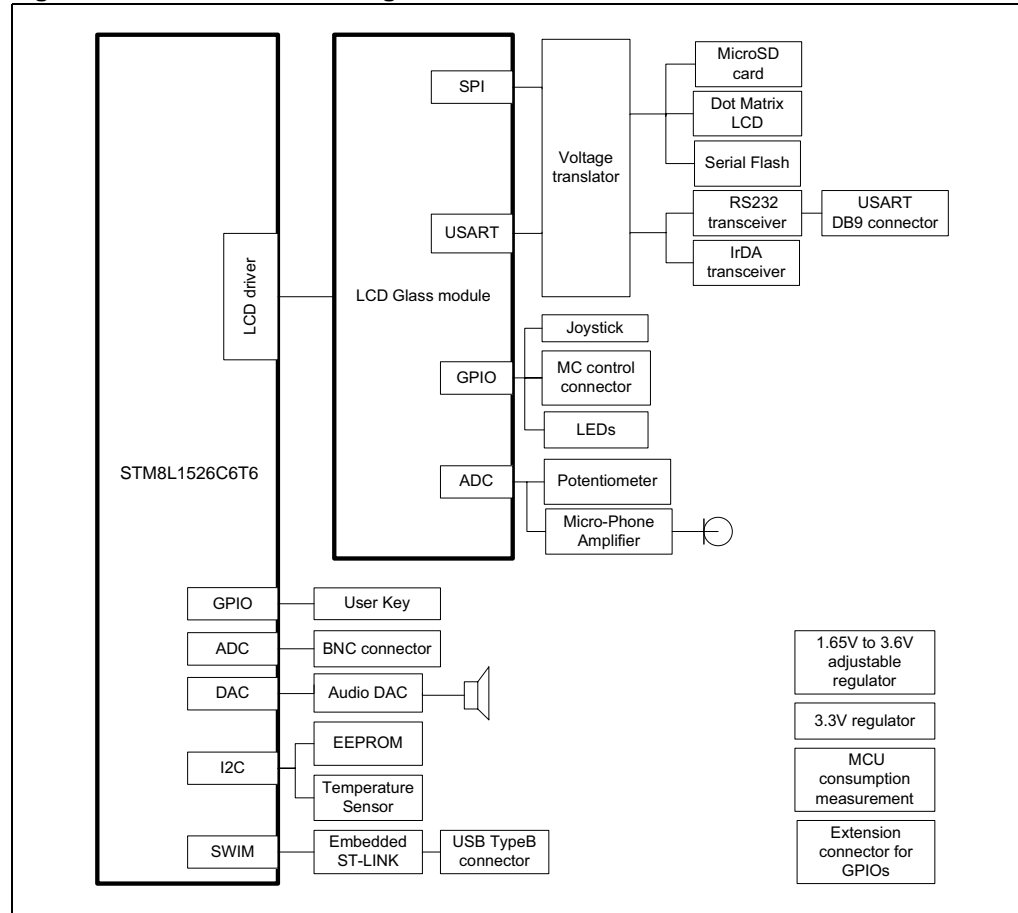

Figure 3. STM8L1526-EVAL layout

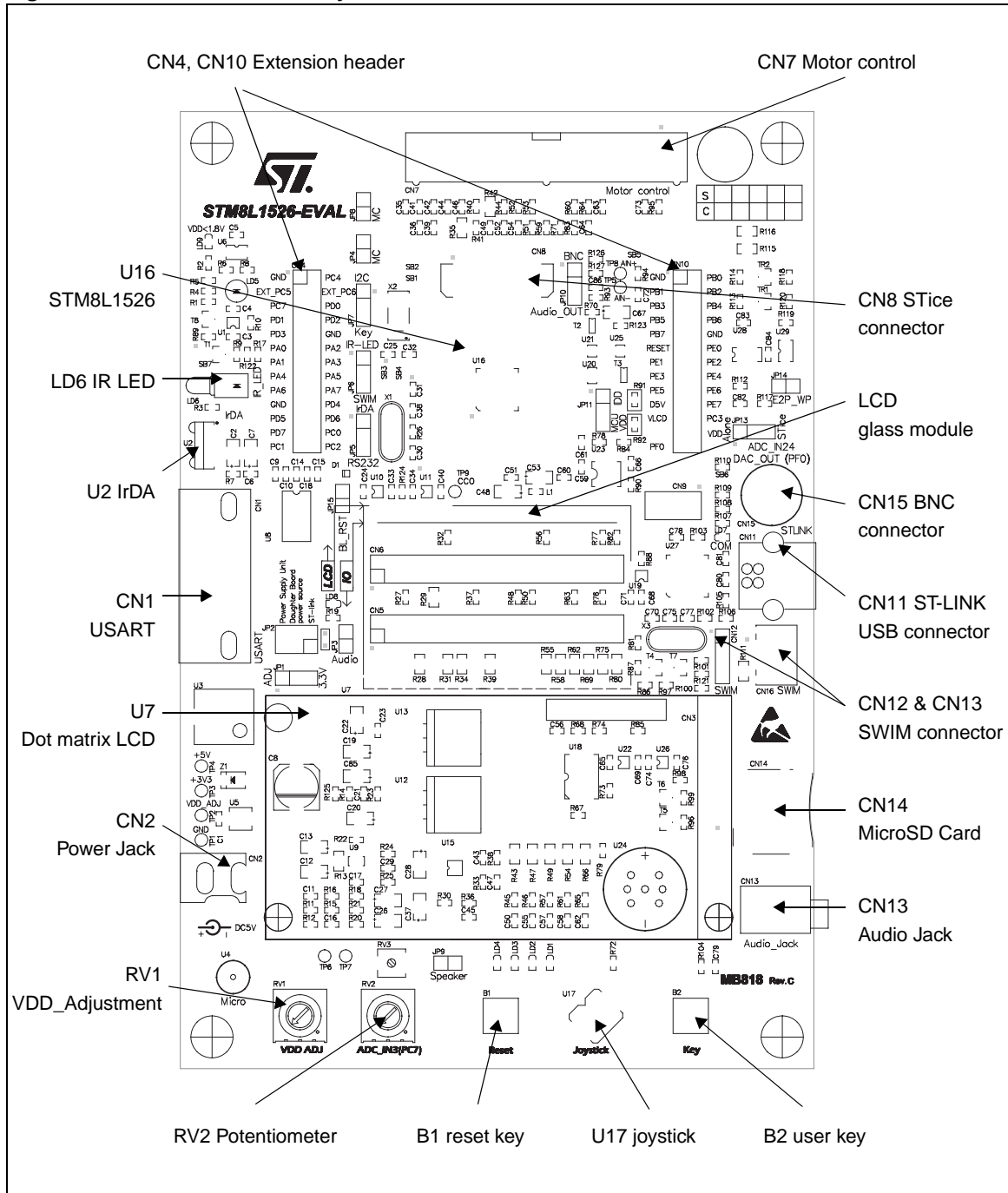
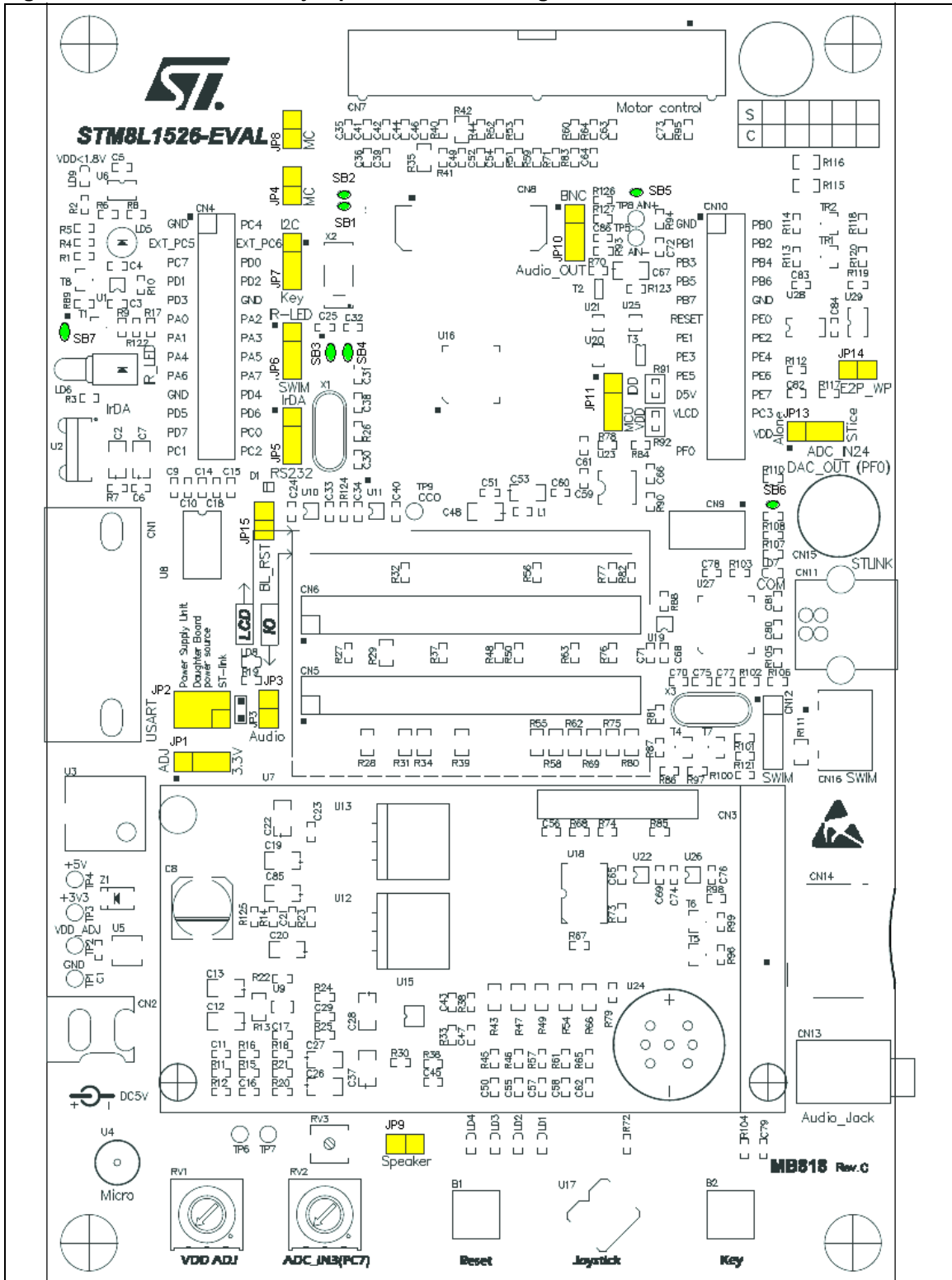

Figure 4. STM8L1526-EVAL jumpers and solder bridges



2.1 Power supply

The STM8L1526-EVAL is designed to be powered by a 5 V DC power supply and to be protected by PolyZen from a wrong power plug-in event. It is possible to configure the evaluation board to use any of following three power supply sources.

1. 5 V DC power adapter connected to CN2, the power jack on the board (power supply unit (PSU) on silk screen).
- 5 V DC power with 500 mA limitation from CN11, the USB type B connector for ST-LINK (ST-link on silkscreen (STL)).
 - 5 V DC power from CN10, the extension connector for daughterboard (daughterboard power source (DTB) on silkscreen).

The power supply is configured by setting the related jumpers JP1, JP2 and JP11 as described in [Table 1](#).

Table 1. Power related jumpers: JP1, JP2, JP11

Jumper	Description	Setting
JP2	JP2 selects one of the three possible power supply resources. For power supply jack(CN2) to the STM8L1526-EVAL only, JP2 is set as shown to the right.	
	For power supply from the daughterboard connectors(CN10) to STM8L1526-EVAL only, JP2 is set as shown to the right.	
	For power supply from ST-LINK connector (CN11) to STM8L1526-EVAL only, JP2 is set as shown to the right (default setting).	
	For power supply from power supply jack (CN2) to both STM8L1526-EVAL and daughterboard connected on CN4 and CN10, JP2 is set as shown to the right (daughterboard must not have its own power supply connected).	
JP1	VDD is connected to fixed +3.3 V DC power when JP1 is set as shown to the right (default setting).	
	VDD is connected to adjustable DC power from 1.65 V to 3.6 V when JP1 is set as shown to the right.	
JP11	VDD power is directly connected to MCU VDD when JP11 is set as shown to the right. Note: For manual IDD measurement the jumper on JP11 must be removed and replaced by an ammeter connected between JP11 pin 2 and pin 3.	
	Connect VDD power to MCU with current-sampling resistor, 2 ohm or 2 Kohm, in-series for IDD current measurement when JP11 is set as shown to the right (default setting).	

To enable MCU power consumption measurement, JP11, JP3 and LCD glass module should be re-configured as described in [Table 1](#) and [Table 2](#).

Table 2. MCU power consumption measurement related jumpers

Jumper	Description
JP3	The microphone output is connected to ADC of the STM8L152C6 when JP3 is closed. Default setting: Fitted
	For MCU power consumption measurement, JP3 must be kept open to avoid current injection. For motor control application, JP3 must be kept open to avoid conflict between the speaker and motor control connector, CN7.
LCD glass module	The LCD glass module must be mounted on the "IO" position for MCU power consumption measurement. Refer to Section 2.4: LCD glass module for details.

The LED LD8 is lit when the STM8L1526-EVAL evaluation board is powered by the 5 V correctly, the LED LD9 is lit if the MCU is powered by a low voltage ($VDD < 1.8$ V).

Note: The AC220V to DC5V power adapter PSU-5V2A (recommended, can be ordered from ST, it is not provided with board by default) or equivalent (polarity compatible with CN2) can be used to power the STM8L1526-EVAL board via the power jack CN2 on the board. To order the recommended power supply, use the order code PSU-5V2A.

2.2 Clock source

Two clock sources are available on the STM8L1526-EVAL for the STM8L152C6 and embedded RTC.

- X2, 32 kHz crystal for embedded RTC
- X1, 16 MHz crystal with socket for the STM8L152C6 microcontroller, it can be removed from the socket when the internal RC clock is used.

Table 3. 32 kHz crystal X2 related solder bridges

Solder bridge	Description
SB3	PC5 is connected to 32 kHz crystal when SB3 is set as pad1 connected to pad2 (default setting).
	PC5 is connected to STice connector CN8 and extension connector CN4 when SB3 is set as pad2 connected to pad3.
SB4	PC6 is connected to 32 kHz crystal when SB4 is set as pad2 connected to pad3 (default setting).
	PC6 is connected to STice connector CN8 and extension connector CN4 when SB4 is set as pad1 connected to pad2.

Note: I/O ports PA2 and PA3 can be used as GPIO on extension connector by closing solder bridges SB1 and SB2 when crystal X1 is removed from its socket.

2.3 Reset source

The reset signal of the STM8L1526-EVAL is low active and the reset sources include:

- Reset button B1
- Debugging tools from SWIM connector CN12 and CN16
- Daughterboard from CN10
- Embedded ST-LINK
- RS-232 connector CN1 for ISP

Table 4. Reset related jumpers

Jumper	Description	Setting						
JP15	The board Reset is managed by pin 1 of connector CN1 (RS-232 DCD signal) when JP15 is closed. This configuration is used for boot loader application only. Default Setting: Not fitted							
JP13	PA1 is connected to the Reset source listed above when JP13 is set as shown to the right: (Default setting).	<table style="display: inline-table; border-collapse: collapse;"> <tr> <td style="padding: 0 5px;">1</td> <td style="padding: 0 5px;">2</td> <td style="padding: 0 5px;">3</td> </tr> <tr> <td style="text-align: center;">●</td> <td style="text-align: center;">●</td> <td style="text-align: center;">●</td> </tr> </table>	1	2	3	●	●	●
1	2	3						
●	●	●						
	PA1 is connected to ground when JP13 is set as shown to the right. So, the MCU is kept on Reset when you connect STice to CN8 for debugging.	<table style="display: inline-table; border-collapse: collapse;"> <tr> <td style="padding: 0 5px;">1</td> <td style="padding: 0 5px;">2</td> <td style="padding: 0 5px;">3</td> </tr> <tr> <td style="text-align: center;">●</td> <td style="text-align: center;">●</td> <td style="text-align: center;">□</td> </tr> </table>	1	2	3	●	●	□
1	2	3						
●	●	□						

2.4 LCD glass module

An LCD glass module (MB821) with 8-digit liquid crystal display is mounted on the STM8L1526-EVAL evaluation board. It can be connected to the LCD driver of the STM8L152C6 MCU or can work as a set of jumpers by mounting it in two possible positions, position IO or position LCD.

- Position IO. All peripherals (USART, IrDA, MicroSD Card, dot matrix LCD, serial Flash, LEDs, joystick, bicolor LED, potentiometer, MCU consumption measurement, motor control and microphone) shared with LCD glass are connected to the STM8L152C6 and the LCD glass is disconnected when LCD glass module is mounted on position IO as shown below (default setting). See [Figure 5](#).
- Position LCD. LCD glass is connected to the LCD driver of the STM8L152C6 and all peripherals shared with the LCD glass are disconnected when the LCD glass module is mounted on position LCD as shown below. In this position, as well as the LCD, there are other resources available on the board:
 - I2C EEPROM or Key button depending on JP7 jumper position
 - Audio speaker amplifier or BNC depending on JP10 jumper position.
 - IR LED depending on JP6 jumper position.

See [Figure 6](#).

Figure 5. LCD glass module in position I/O

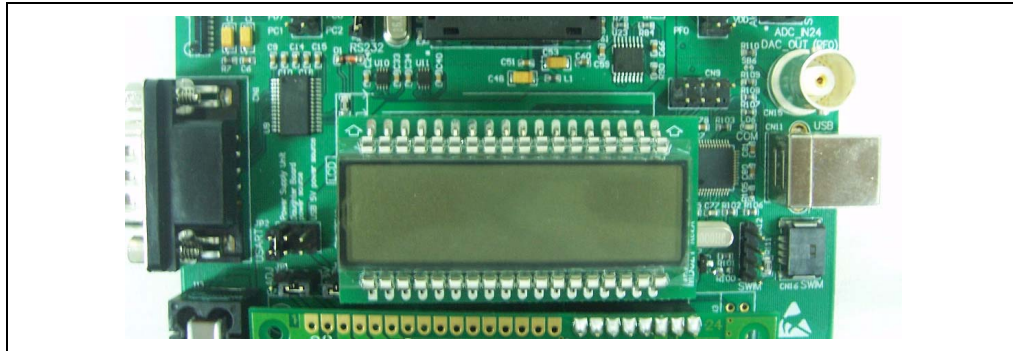
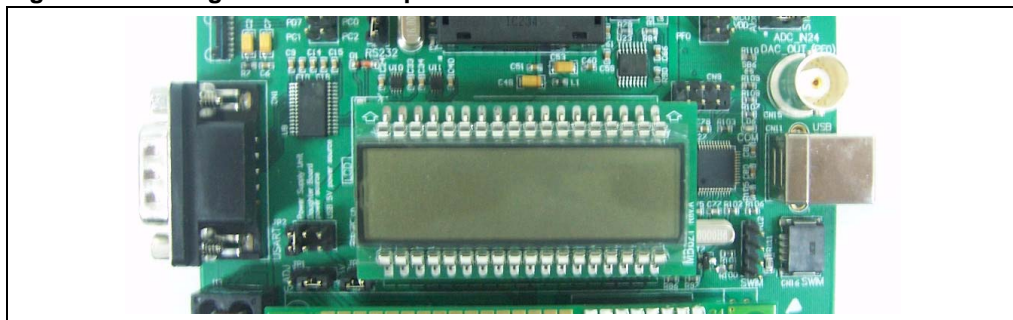

Figure 6. LCD glass module in position LCD



2.5 Audio

The STM8L1526-EVAL supports:

- a speaker connected to the DAC output of the STM8L152C6 through an audio amplifier which can be enabled or disabled by setting JP9. The choice between BNC or DAC output on PF0 is done by JP10, refer to [Table 5](#) for details.
- a microphone connected to the ADC input of the STM8L152C6 through a microphone amplifier. The microphone output can be connected or disconnected to the STM8L152C6 by setting JP3 to closed or open, refer to [Table 2](#) for details.

Table 5. Audio related jumpers

Jumper	Description	Setting						
JP9	The speaker amplifier is enabled when JP9 is closed. Default setting: Fitted							
JP10	PF0 is connected to BNC connector CN15 when JP10 is set as shown to the right.	<table border="1"> <tr> <td>1</td> <td>2</td> <td>3</td> </tr> <tr> <td>●</td> <td>●</td> <td>●</td> </tr> </table>	1	2	3	●	●	●
	1	2	3					
●	●	●						
	PF0 is connected to speaker when JP10 is set as show to the right (default setting).	<table border="1"> <tr> <td>1</td> <td>2</td> <td>3</td> </tr> <tr> <td>●</td> <td>○</td> <td>○</td> </tr> </table>	1	2	3	●	○	○
1	2	3						
●	○	○						

The LCD glass module must be mounted on "IO" position for Microphone. Refer to [Section 2.4: LCD glass module](#) for details.

2.6 EEPROM

A 64 KBit EEPROM is connected to the I2C bus of the STM8L152C6.

Table 6. EEPROM related jumpers

Jumper	Description	Setting
JP14	The I2C EEPROM U29 is in write protection mode when JP14 is not fitted. Default setting: Fitted	
JP7	PC1 is connected to the User button when JP7 is set as shown to the right .	1 2 3 ● ● ●
	PC1 is connected to I2C_SCL when JP7 is set as shown to the right (default setting).	1 2 3 ● ● ●

Note: The E2PROM used on the board (ref M24C64-DFW5TP) is limited in VDD range from 1.7 to 5.5 V by specification therefore its behavior is not guaranteed for VDD from 1.65 to 1.7 V.

2.7 RS-232 and IrDA

Both RS-232 and IrDA communication is supported by D-type 9-pin RS-232 connectors CN1 and IrDA transceiver U2 which connect to the USART of the STM8L152C6 on the STM8L1526-EVAL evaluation board.

The signal Bootloader_RESET is added on the RS-232 connector for ISP support.

RS-232 or IrDA can be selected by setting JP5.

Table 7. RS-232 and IrDA related jumper

Jumper	Description	Setting
JP5	USART_RX is connected to the RS-232 transceiver and RS-232 communication is enabled when JP5 is set as shown to the right (default setting).	1 2 3 ● ● ●
	USART_RX is connected to the IrDA transceiver and IrDA communication is enabled when JP5 is set as shown to the right.	1 2 3 ● ● ●

The LCD glass module must be mounted in the IO position for RS-232 and IrDA. Refer to [Chapter 2.4: LCD glass module](#) for details.

Note: Hardware flow control is not supported by the RS-232 interface (CTS and RTS not managed by MCU).

2.8 Motor control

The STM8L1526-EVAL supports three-phase brushless motor control via a 34-pin connector, CN7, which provides all required control and feedback signals to and from motor power-driving board. Available signals on this connector include emergency stop, motor speed, 3 phase motor current, bus voltage, heat sink temperature coming from the motor driving board and 6 channels of PWM control signal going to the motor driving circuit.

The I/O pins used on the motor control connector, CN7, are multiplexed with some peripherals on the board. The motor control application can be enabled by setting jumpers JP3, JP4 and JP8.

Table 8. Motor control related jumpers

Jumper	Description
JP4	JP4 redirects the PFC synchronization signal to the timer 3 input capture 2 pin, additionally to the timer3 external trigger input. Default setting: Not Fitted.
JP8	JP8 should be kept open when the encoder signal is input from pin31 of CN7. JP8 should be kept closed when analog signal is from pin31 of CN7 for special motor. Default setting: Not Fitted.
JP3	For motor control application, JP3 must be kept open to avoid conflict between speaker and motor control connector, CN7.

Some rework that is required to be done to the board is listed below:

- Remove 0 ohm resistors, R69, R75, R80, R58, R35, R42, R31, R34, R62, R39, R55 and R48 (all resistors are marked in red in [Figure 7](#)) to release I/Os used by motor control and shared with another peripherals.
- Remove MicroSD Card from SD Card socket CN14 (SD Card socket is marked in red in [Figure 7](#)).
- Solder resistor R82 (0 ohm), R59 (0 ohm) and R29 (0 ohm), all components to be soldered are marked in green in [Figure 7](#).

The LCD glass module has to be mounted in the IO position for motor control. Refer to [Section 2.4: LCD glass module](#) for details.

Figure 7. STM8L1526-EVAL motor control re-configuration of board

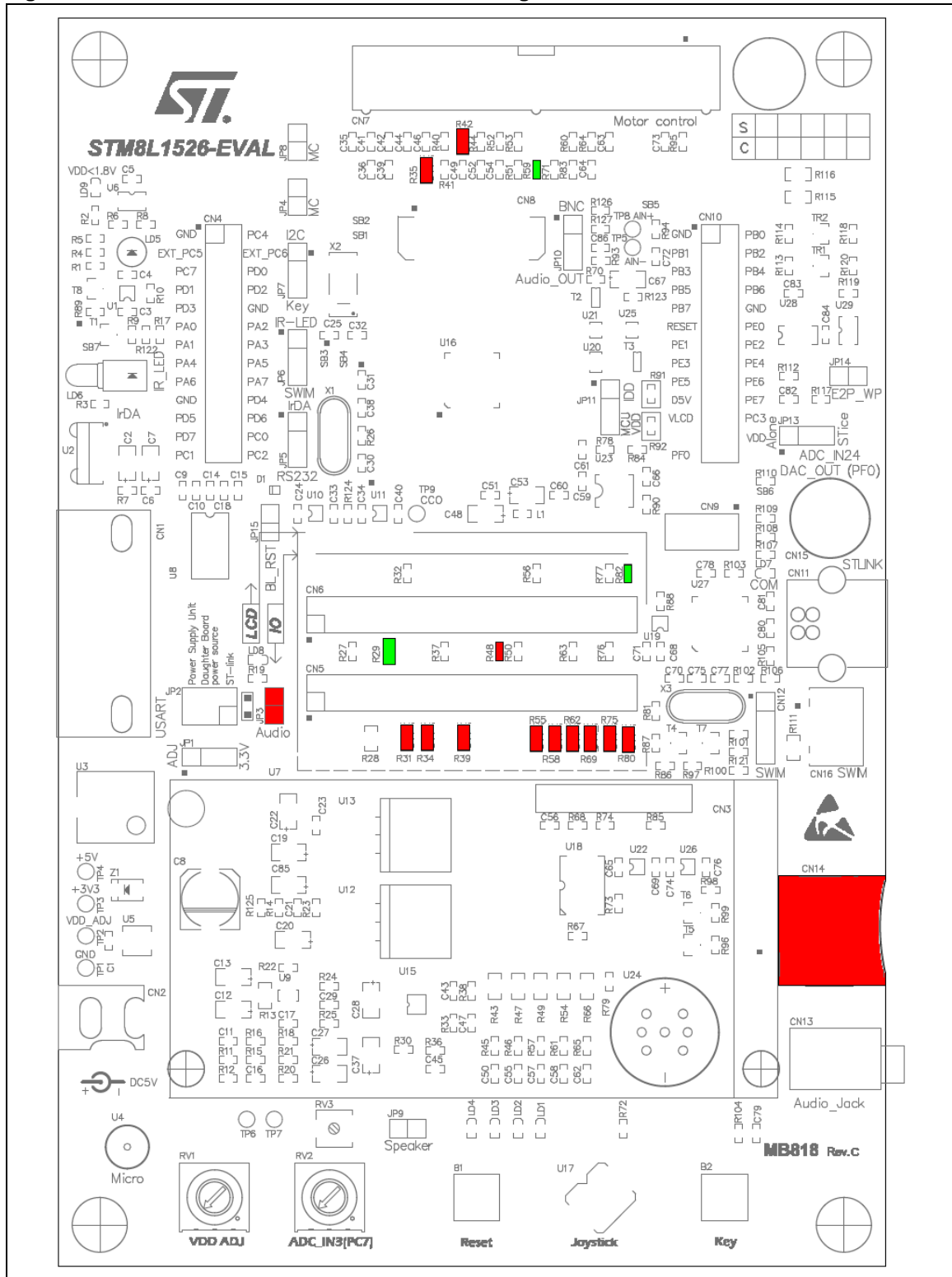

2.9 MicroSD Card

The 1 GByte MicroSD Card connected to the SPI port of the STM8L152C6 is available on the board. MicroSD Card detection is managed by standard I/O port, PD6.

The LCD glass module must be mounted in the IO position for MicroSD Card. Refer to [Chapter 2.4: LCD glass module](#) for details.

2.10 Analog input

The BNC connector, CN15, is connected to PF0 of the STM8L152C6 as an external analog input or DAC output. The 50 ohm terminal resistor can be enabled by closing solder bridge SB6. A low-pass filter can be implemented for the BNC connector by replacing R126 and C86 for ADC input or replacing R127 and C86 for DAC output (with suitable resistor and capacitor as requested by end user's application).

There are also 3 analog signals available on the board.

1. 10 Kohm potentiometer RV2 connected to PC7.
2. IDD measurement output signal connected to PD3 for MCU power consumption test.
3. External ADC input which can be connected to TP8 (AIN+) and TP5 (AIN-). Solder bridge SB5 should be kept on open for this analog input.

The LCD glass module has to be mounted in the IO position for IDD measurement and potentiometer RV2. Refer to [Section 2.4: LCD glass module](#) for details.

2.11 Serial Flash

The M25P128 serial Flash is connected to the SPI bus of the STM8L152C6. The chip select is managed by standard I/O port, PE4.

The LCD glass module has to be mounted in the IO position for serial Flash. Refer to [Section 2.4: LCD glass module](#) for details.

2.12 Temperature sensor

A temperature sensor STLM75M2E is connected to the I2C bus of the STM8L152C6 through two transistors to support a wide voltage range from 1.8 V to 3.3 V on the I2C bus. A voltage lower than 1.8 V is not supported due to the VGS threshold of transistor TR1 and TR2.

The LCD glass module has to be mounted in the IO position for the I2C_SMB signal. Refer to [Section 2.4: LCD glass module](#) for details.

2.13 Development and debug support

An embedded ST-LINK, STM8 debugger developed by STMicroelectronics, is available on the STM8L1526-EVAL as the default debugger. Third-party debuggers are also supported by the SWIM connector, CN12, or low-cost SWIM connector, CN16.

The SWIM connector or embedded ST-LINK can be enabled by setting jumper JP6.

Table 9. SWIM debugging related jumper

Jumper	Description	Setting						
JP6	PA0 is connected to SWIM connector CN12, CN16 and embedded ST-LINK when JP6 is set as shown to the right (default setting).	<table style="border-collapse: collapse; text-align: center;"> <tr> <td style="padding: 0 5px;">1</td> <td style="padding: 0 5px;">2</td> <td style="padding: 0 5px;">3</td> </tr> <tr> <td style="padding: 0 5px;">●</td> <td style="padding: 0 5px;">●</td> <td style="padding: 0 5px;">●</td> </tr> </table>	1	2	3	●	●	●
	1	2	3					
●	●	●						
PA0 is connected to IR LED, LD6 when JP6 is set as show to the right.	<table style="border-collapse: collapse; text-align: center;"> <tr> <td style="padding: 0 5px;">1</td> <td style="padding: 0 5px;">2</td> <td style="padding: 0 5px;">3</td> </tr> <tr> <td style="padding: 0 5px;">●</td> <td style="padding: 0 5px;">●</td> <td style="padding: 0 5px;">●</td> </tr> </table>	1	2	3	●	●	●	
1	2	3						
●	●	●						

A 60-pin connector CN8 is available also for STIce user, it can be used even with MCU silicon mounted on the board by setting jumper JP13. (The STIce connector is available only on the MB818 with an MCU socket).

Table 10. STIce related jumper

Jumper	Description	Setting						
JP13	PA1 is connected to Reset sources when JP13 is set as shown to the right, the board is working on standalone mode without STIce connected (default setting).	<table style="border-collapse: collapse; text-align: center;"> <tr> <td style="padding: 0 5px;">1</td> <td style="padding: 0 5px;">2</td> <td style="padding: 0 5px;">3</td> </tr> <tr> <td style="padding: 0 5px;">●</td> <td style="padding: 0 5px;">●</td> <td style="padding: 0 5px;">●</td> </tr> </table>	1	2	3	●	●	●
	1	2	3					
●	●	●						
PA1 is connected to GND when JP13 is set as show to the right. All I/Os of STM8L152C6 silicon on the board is kept on "floating input" which allows debugging based on STIce connected to CN8.	<table style="border-collapse: collapse; text-align: center;"> <tr> <td style="padding: 0 5px;">1</td> <td style="padding: 0 5px;">2</td> <td style="padding: 0 5px;">3</td> </tr> <tr> <td style="padding: 0 5px;">●</td> <td style="padding: 0 5px;">●</td> <td style="padding: 0 5px;">●</td> </tr> </table>	1	2	3	●	●	●	
1	2	3						
●	●	●						

2.14 Display and input devices

The 122x32 dot-matrix LCD connected to the SPI port of the STM8L152C6, 4 general purpose color LED's (LD 1,2,3,4), and one bicolor LED LD5 are available as display devices. The 4-direction joystick (U17) with selection key and general purpose button (B2) are available as input devices.

The STM8L1526-EVAL evaluation board also supports a second optional 2.4" TFT LCD that can be mounted on the CN3 connector. The 2.4" TFT LCD is not populated by default. MB542 is the reference of the 2.4" TFT LCD to be connected on CN3.

Table 11. LCD modules

122x32 dot-matrix LCD U7 (default)			2.4" TFT LCD CN3 (optional)		
Pin on U7	Description	Pin connection	Pin on CN3	Description	Pin connection
1	Vss	GND	1	CS	PB4
2	Vcc	+3.3V	2	SCL	PB5
3	VO	-	3	SDI	PB6
4	CLK	PB5	4	RS	-
5	SID	PB6	5	WR	-
6	CS	PB4	6	RD	-
7	A	+5V	7	SDO	PB7
8	K	GND	8	RESET	RESET#
			9	VDD	3.3V
			10	VCI	3.3V
			11	GND	GND
			12	GND	GND
			13	BL_VDD	3.3V
			14	BL_Control	3.3V
			15	BL_GND	GND
			16	BL_GND	GND

The LCD glass module must be mounted on the "IO" position for LCD, LED's and joystick. Refer to [Section 2.4: LCD glass module](#) for details.

2.15 IDD measurement and comparator

For IDD measurement the circuit shown in [Figure 9](#) is implemented on the STM8L1526-EVAL.

Figure 8. STM8L1526-EVAL IDD measurement circuit

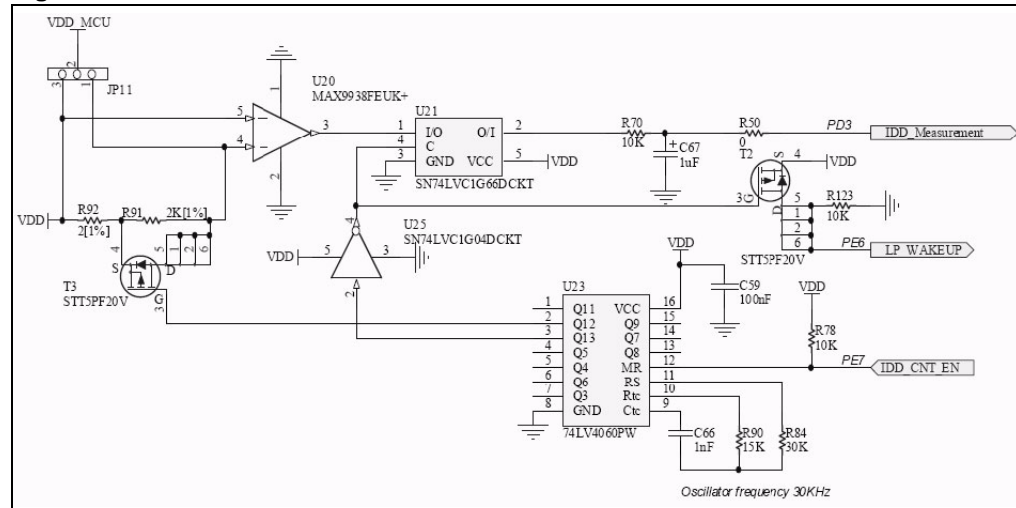

In Run mode, IDD current is measured using MAX9938FEUK+ (U20) connected to the 20ohm shunt resistor. In this case IDD_CNT_EN remains at a high level during measurement and the jumper must be connected between pin 1 and pin 2 of JP11.

In Halt mode, the operational amplifier MAX9938FEUK+ (U20) is connected on the 2 Kohm shunt resistor. To measure a current corresponding to the Halt mode the procedure is:

1. Configure ADC to measure voltage on IDD_measurement pin.
2. Configure PE6 as interrupt input on falling edge.
3. Enter in Halt or active Halt mode with IDD_CNT_EN low.
4. LP_WAKEUP falling edge wakeup the MCU after 150 ms.
5. Start ADC conversion as soon as possible after wakeup in order to measure the voltage corresponding to low power mode on 1 uF capacitor.
6. Reset the counter by programming IDD_CNT_EN high to avoid 2 Kohm to be connected later on VDD_MCU.

In Halt mode, the 2 K resistor is connected when T3 goes off after entering Halt mode. Q12 output of the counter allows connection of the 2 K when the current IDD becomes very low. The measurement timing is given in [Figure 9](#).

Figure 9. STM8L1526-EVAL IDD Halt mode measurement timing diagram

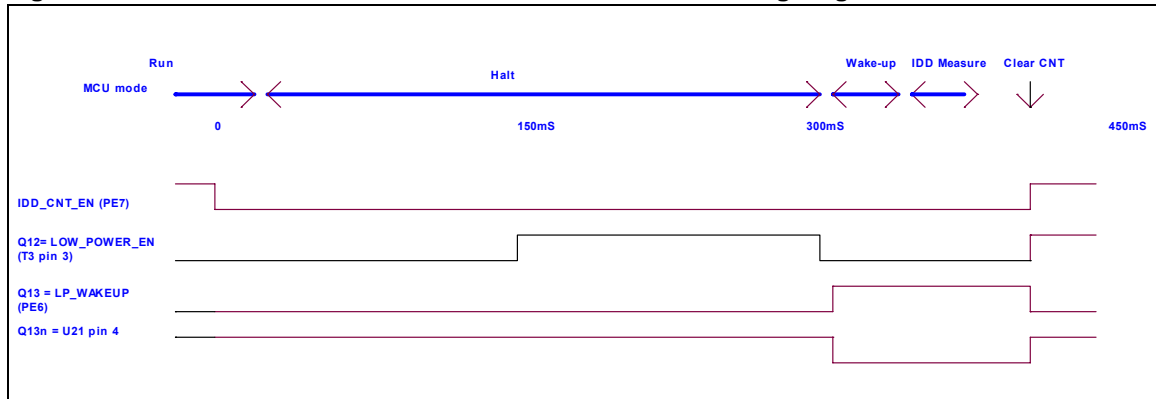

The Halt mode measurement procedure can be used in Halt mode and slow or fast active Halt modes if the IDD current does not exceed 12 uA else the Run measurement procedure should be used up to 12 mA.

2.16 Comparator

Three I/Os are used to implement a comparator feature to be used as low precision ADC in [Figure 10](#).

- Comparator noninverting input PD1 connected to the reference capacitor (Cref).
- One I/O PE0 used as output, connected to the reference resistor (Rref) used to charge Cref.
- Comparator inverting input used as ADC input PC7 to be connected to the potentiometer.

Figure 10. STM8L1526-EVAL low precision ADC based on comparator

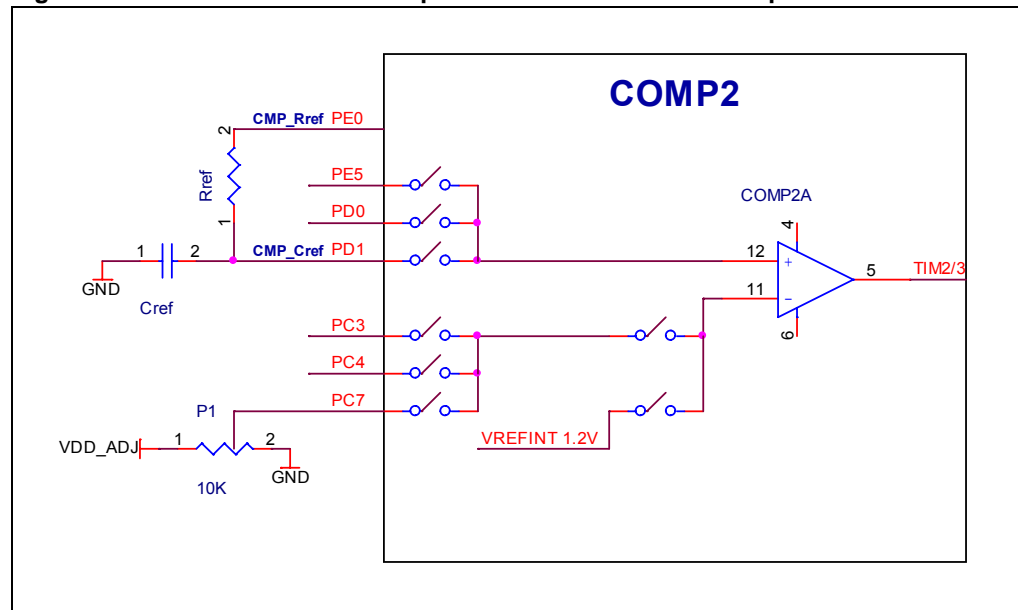

The measurement is performed in three steps:

1. Internal reference voltage VREFINT is connected to the comparator inverting input and Cref to noninverting input to measure the time required to charge the capacitor to internal reference voltage VREFINT by PE0 used as output through Rref.
2. The potentiometer is connected to inverting input to measure the time required to charge Cref to the voltage on potentiometer.
3. The potentiometer voltage is calculated by software interpolation or using a conversion table.

2.17 IR LED

One IR LED, LD6, is driven by either PA0 through two transistors T1 and T8, or PA0 directly; depending on the setting of the solder bridge SB7.

Table 12. IR LED related solder bridges

Solder bridge	Description
SB7	LD6 is driven by PA0 through two transistors, T1 and T8, when SB7 is set as pad1 connected to pad2 (default setting).
	LD6 is driven by PA0 directly when SB7 is set as pad2 connected to pad3.

Note: JP6 needs to be set correspondingly for IR LED, please refer to [Table 9](#) for details.

3 Connectors

3.1 RS-232 connector CN1

Figure 11. RS-232 connector CN1 with ISP support

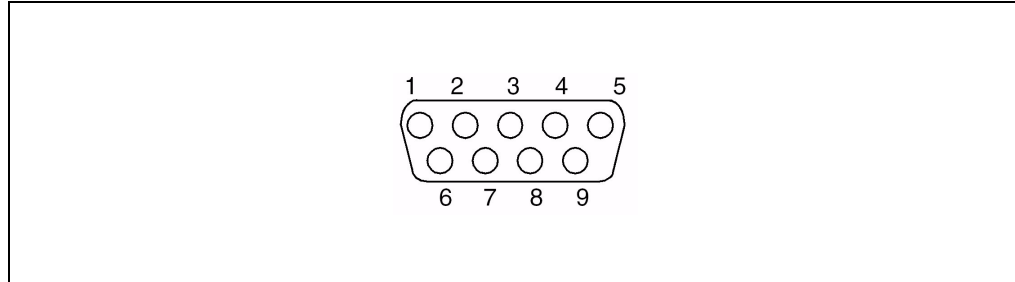

Table 13. RS-232 connector CN1 with ISP support

Pin number	Description	Pin number	Description
1	Bootloader_RESET	6	NC
2	RS232_RX (PC2)	7	NC
3	RS232_TX (PC3)	8	NC
4	NC	9	NC
5	GND		

3.2 Power connector CN2

The STM8L1526-EVAL evaluation board can be powered from a DC 5 V power supply via the external power supply jack (CN2) shown in [Figure 12](#). The central pin of CN2 must be positive.

Figure 12. Power supply connector CN2 viewed from front

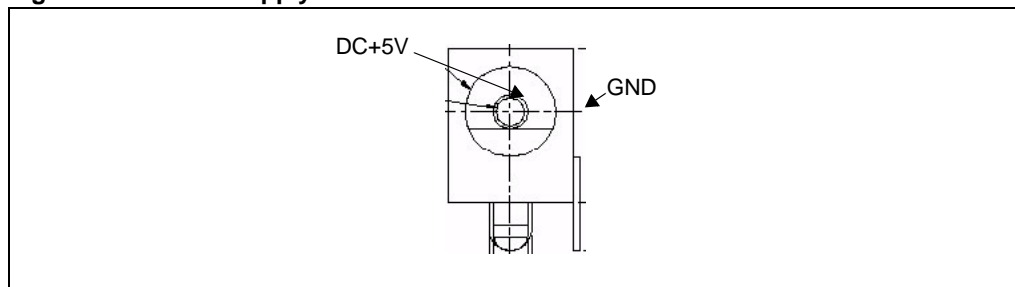

3.3 TFT LCD connector CN3

CN3 is used to support TFT color LCD board (MB542), it is not populated by default.

3.4 Daughterboard extension connector CN4 and CN10

Two 26-pin male headers CN4 and CN10 can be used to connect the daughterboard or standard wrapping board to the STM8L1526-EVAL evaluation board. All GPIOs are available on it. The space between these two connectors and position of power, GND and RESET pin are defined as a standard which allows to develop common daughterboards for several evaluation boards. The standard width between CN4 pin1 and CN10 pin1 is 2700 mils (68.58mm). The standard was implemented on the majority of evaluation boards.

Each pin on CN4 and CN10 can be used by a daughterboard after disconnecting it from the corresponding function block on the STM8L1526-EVAL evaluation board. Please refer to [Table 14](#) and [Table 15](#) for details.

Table 14. Daughterboard extension connector CN4

Pin	Description	Alternative function	How to disconnect with function block on STM8L1526-EVAL board
1	GND	-	
3	PC5	32 kHz crystal	Set SB3 to 2<->3
5	PC7	Potentiometer	Remove R28
7	PD1	CMP_Cref / Motor control connector (PFC sync)	Remove R35
9	PD3	IDD_Measurement	Remove R50
11	PA0	SWIM / IR_LED	Set JP6 to open
13	PA1	RESET button	Set JP13 to open
15	PA4	LED1 / Motor control connector (Current A)	Remove R69 Disconnect power driver board from Motor control connector
17	PA6	LED3 / Motor control connector (Current C)	Remove R80 Disconnect power driver board from Motor control connector
19	GND	-	
21	PD5	Joystick_right / Motor control connector (MC_WH)	Remove R34 Disconnect power driver board from Motor control connector
23	PD7	Joystick_up / Motor control connector (MC_UL)	Remove R31 Disconnect power driver board from Motor control connector
25	PC1	I ² C SDA	Set JP7 to open
2	PC4	I ² C SMB	Remove R27
4	PC6	32 kHz crystal	Set SB4 to 1<->2
6	PD0	Motor control connector (PFC sync)	Disconnect power driver board from Motor control connector
8	PD2	Bicolor_LED / Motor control connector (MC_UH)	Remove R48 Disconnect power driver board from Motor control connector

Table 14. Daughterboard extension connector CN4 (continued)

Pin	Description	Alternative function	How to disconnect with function block on STM8L1526-EVAL board
10	GND	-	
12	PA2	16MHZ crystal	Set SB2 to close Remove X1 and C30
14	PA3	16MHZ crystal	Set SB1 to close Remove X1 and C38
16	PA5	LED2 / Motor control connector (Bus voltage)	Remove R75
18	PA7	LED4 / Motor control connector (Encoder index)	Remove R58 Disconnect power driver board from Motor control connector
20	PD4	Joystick_down / Motor control connector (MC_VH)	Remove R39 Disconnect power driver board from Motor control connector
22	PD6	Motor control connector (EmergencySTOP) / SDcard_detect	Remove SD Card from card socket
24	PC0	I ² C SDA	Remove R115
26	PC2	UART_IrDA_RX	Set JP5 to open

Table 15. Daughterboard extension connector CN10

Pin	Description	Alternative function	How to disconnect with component on STM8L1526-EVAL board
1	GND	-	-
3	PB1	Motor control connector (Dissipative brake & PFC PWM)	Disconnect power driver board from Motor control connector
5	PB3	Audio_ADC_IN	Set JP3 to open
7	PB5	LCD_SDcard_Flash_SCK	-
9	PB7	LCD_SDcard_Flash_MISO	Remove R73 and SD Card from card socket
11	RESET#		-
13	PE1	Joystick_Left / Motor control connector (MC_VL)	Remove R62 Disconnect power driver board from Motor control connector
15	PE3	Micro SD card_CS	Remove SD Card from card socket
17	PE5	Motor control connector (MC_CurrentB)	Disconnect power driver board from Motor control connector
19	D5V	-	-
21	NC	-	-
23	NC	-	-

Table 15. Daughterboard extension connector CN10 (continued)

Pin	Description	Alternative function	How to disconnect with component on STM8L1526-EVAL board
25	PF0	Motor control connector (Current B) / BNC / Audio_DAC_out	Set JP10 to open
2	PB0	Motor control connector (Encoder A)	Disconnect power driver board from Motor control connector
4	PB2	Motor control connector (Encoder B)	Disconnect power driver board from Motor control connector
6	PB4	Dot-matrix LCD_CS	Remove Dot-Matrix LCD module
8	PB6	LCD_SDcard_Flash_MOSI	-
10	GND	-	-
12	PE0	CMP_Rref / Motor control connector (NTC_bypass)	Remove R42 Disconnect power driver board from Motor control connector
14	PE2	Joystick_sel / Motor control connector (MC_WL)	Remove R55 Disconnect power driver board from Motor control connector
16	PE4	Serial Flash_CS	Remove R73
18	PE6	IDD_Measurement_Wakeup	Remove LCD glass module (MB821) 0ohm resistor to be added?
20	PE7	IDD_Measurement_CNT_EN	-
22	PC3	UART_IrDA_TX	-
24	MCU_VDD		-
26	NC		-

Note: All I/O's marked in grey can be disconnected with function block on the STM8L1526-EVAL board by removing LCD glass module (MB821) board.

3.5 LCD glass connector CN5 and CN6

Two 36-pin male headers, CN5 and CN6, can be used to mount the LCD glass module (MB821) on it. Two possible mount positions may be selected by the user for either an LCD glass demonstration or other peripherals on STM8L1526-EVAL board.

3.6 Motor control connector CN7

Figure 13. Motor control connector CN7 viewed from above

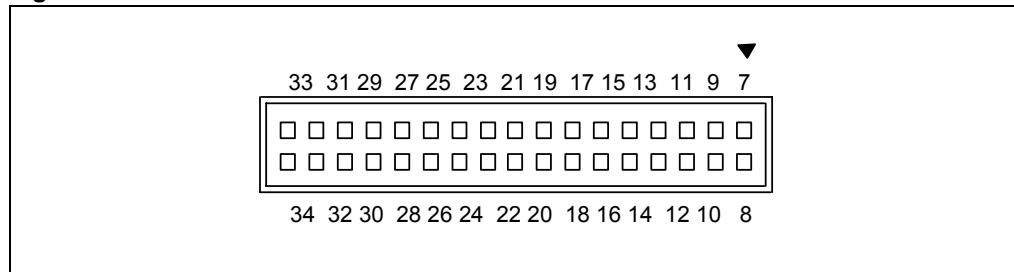

Table 16. Motor control connector CN7

Description	Pin of STM8L152C6	CN17 pin	CN17 pin	Pin of STM8L152C6	Description
EMERGENCY STOP	PD6	1	2		GND
PWM-UH	PD2	3	4		GND
PWM-UL	PD7	5	6		GND
PWM-VH	PD4	7	8		GND
PWM-VL	PE1	9	10		GND
PWM-WH	PD5	11	12		GND
PWM-WL	PE2	13	14	PA5	BUS VOLTAGE
PHASE A CURRENT	PA4	15	16		GND
PHASE B CURRENT	PE5	17	18		GND
PHASE C CURRENT	PA6	19	20		GND
NTC BYPASS RELAY	PE0	21	22		GND
DISSIPATIVE BRAKE PWM	PB1	23	24		GND
+5V power	+5V	25	26	PB3	Heatsink temperature
PFC SYNC	PD0 and PD1	27	28		VDD_Micro
PFC PWM	PB1	29	30		GND
Encoder A	PB0	31	32		GND
Encoder B	PB2	33	34	PA7	Encoder Index

3.7 STice connector CN8

The STice can be connected to emulate the STM8L1526-EVAL board. Jumper JP13 must be set to connect pin 2 and 3 when the STice is connected on CN8. It is used to keep the STM8L152C6 MCU on reset as explained in [Section 2.3: Reset source](#).

Figure 14. STIce debugging connector CN8 viewed from above

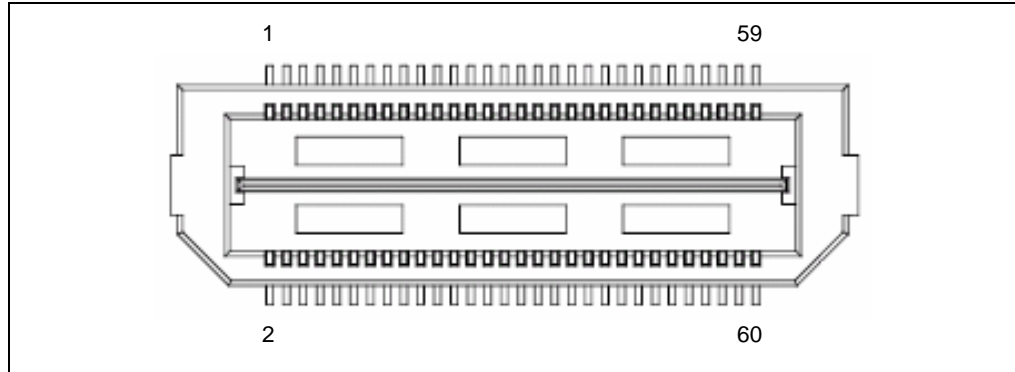

Table 17. STIce debugging connector CN8

Pin number	Description	Pin number	Description
1	PA0	2	RESET#
3	PA2	4	PA3
5	PA4	6	PA5
7	PA6	8	PA7
9	GND	10	VDD_MCU
11	VDDA	12	VDDA
13	VLCD	14	PE0
15	PE1	16	PE2
17	PE3	18	PE4
19	PE5	20	PD0
21	PD1	22	PD2
23	PD3	24	PB0
25	PB1	26	PB2
27	PB3	28	PB4
29	PB5	30	PB6
31	PB7	32	PF0
33	PD4	34	PD5
35	PD6	36	PD7
37	PC0	38	PC1
39	VDD_MCU	40	GND
41	PC2	42	PC3
43	PC4	44	PC5
45	PC6	46	PC7
47	PE6	48	PE7
49-60	NC		

3.8 ST-LINK programming connector CN9

The connector CN9 is used only for embedded ST-LINK programming during board manufacture. It is not populated by default and is not intended for the end user.

3.9 USB type B connector CN11

The USB connector CN11 is used to connect embedded ST-LINK to PC for debugging of board.

Figure 15. USB type B connector CN11 viewed from the front

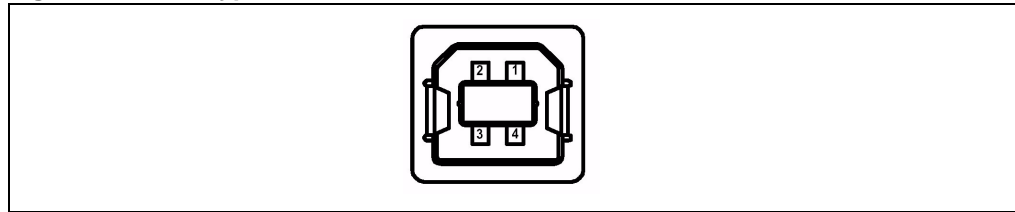

Table 18. USB type B connector CN11

Pin number	Description	Pin number	Description
1	VBUS(power)	4	GND
2	DM	5,6	Shield
3	DP		

3.10 SWIM connector CN12 and CN16

Figure 16. SWIM debugging connector CN16 viewed from the above

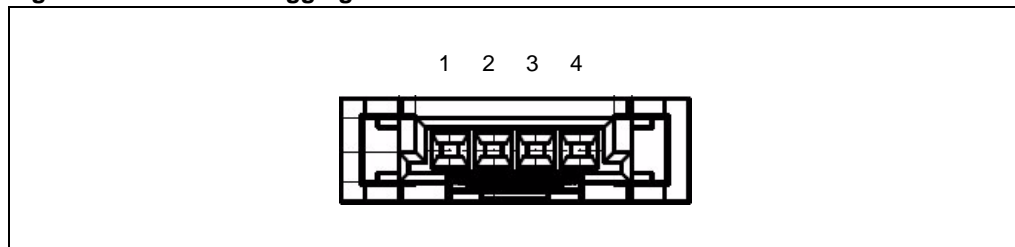

Table 19. SWIM debugging connector CN12 and CN16

Pin number	Description	Pin number	Description
1	VDD	2	SWIM line (PA0)
3	GND	4	RESET#

3.11 Audio jack CN13

A 3.5mm stereo audio jack CN13 connected to audio DAC is available.

3.12 MicroSD connector CN14

Figure 17. MicroSD connector CN14 viewed from the front

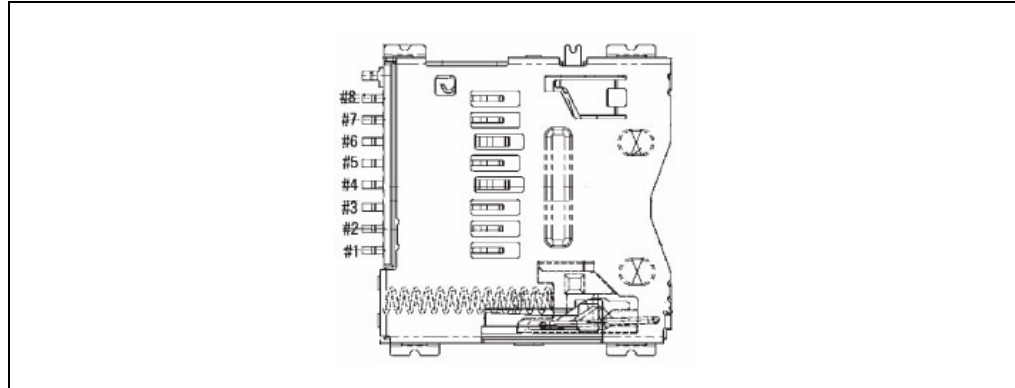

Table 20. MicroSD connector CN14

Pin number	Description	Pin number	Description
1		5	MicroSDcard_CLK (PB5)
2	MicroSDcard_CS (PE3)	6	Vss/GND
3	MicroSDcard_DIN(PB6)	7	MicroSDcard_DOUT(PB7)
4	+3V3	8	
		9	MicroSDcard_detect (PD6)

3.13 BNC connector CN15

Figure 18. Analog input connector CN15 viewed from bottom

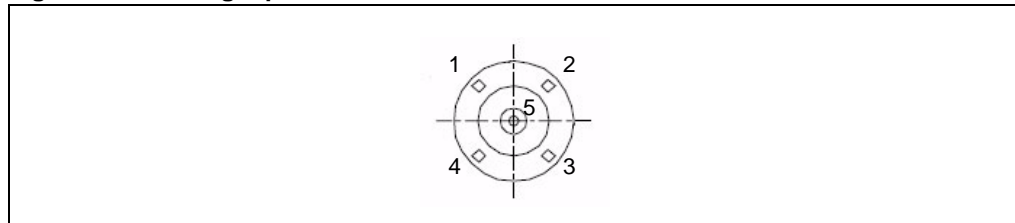

Table 21. Analog input connector CN15

Pin number	Description	Pin number	Description
1	GND	4	GND
2	GND	5	Analog input PF0
3	GND		

4 Schematics

The schematics are shown on the following pages:

- [Table 19: STM8L1526-EVAL on page 30](#)
- [Table 20: MCU on page 31](#)
- [Table 21: LCD glass connector on page 32](#)
- [Table 22: Audio on page 33](#)
- [Table 23: Peripherals on page 34](#)
- [Table 24: Power on page 35](#)
- [Table 25: Extension and STice on page 36](#)
- [Table 26: LCD and SD Card on page 37](#)
- [Table 27: RS-232 and IrDA on page 38](#)
- [Table 28: Motor control on page 39](#)
- [Table 29: EEPROM and temperature sensor on page 40](#)
- [Table 30: ST_LINK \(SWIM only\) on page 41.](#)
- [Table 31: MB821 on page 42](#)



Figure 19. STM8L1526-EVAL

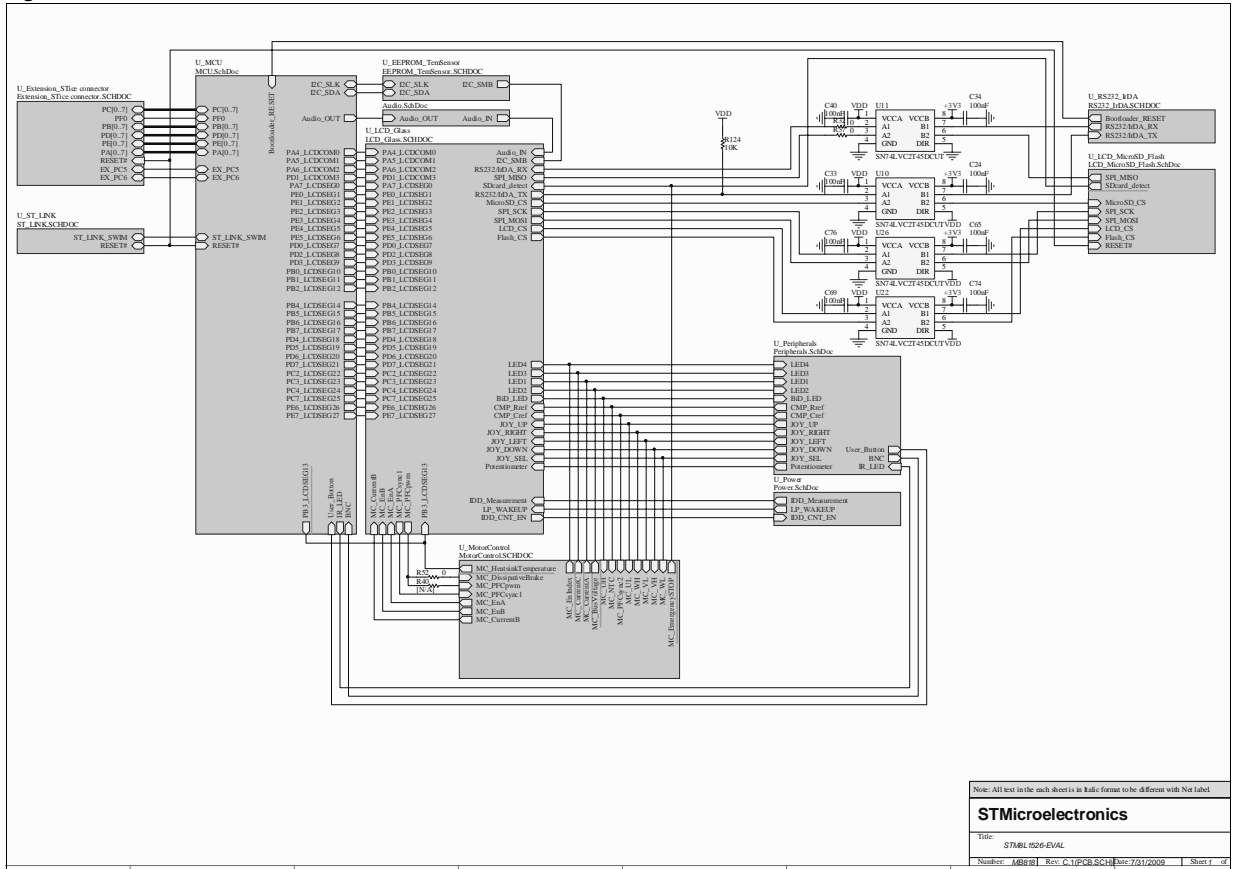

Note: All text in this sheet is in Bold format to be different with Net Label.

STMicroelectronics	
Title	STM8L1526-EVAL
Number	46691 Rev: C (PCB SCL1) 01/23/2009 Sheet 4 of 4



Figure 21. LCD glass connector

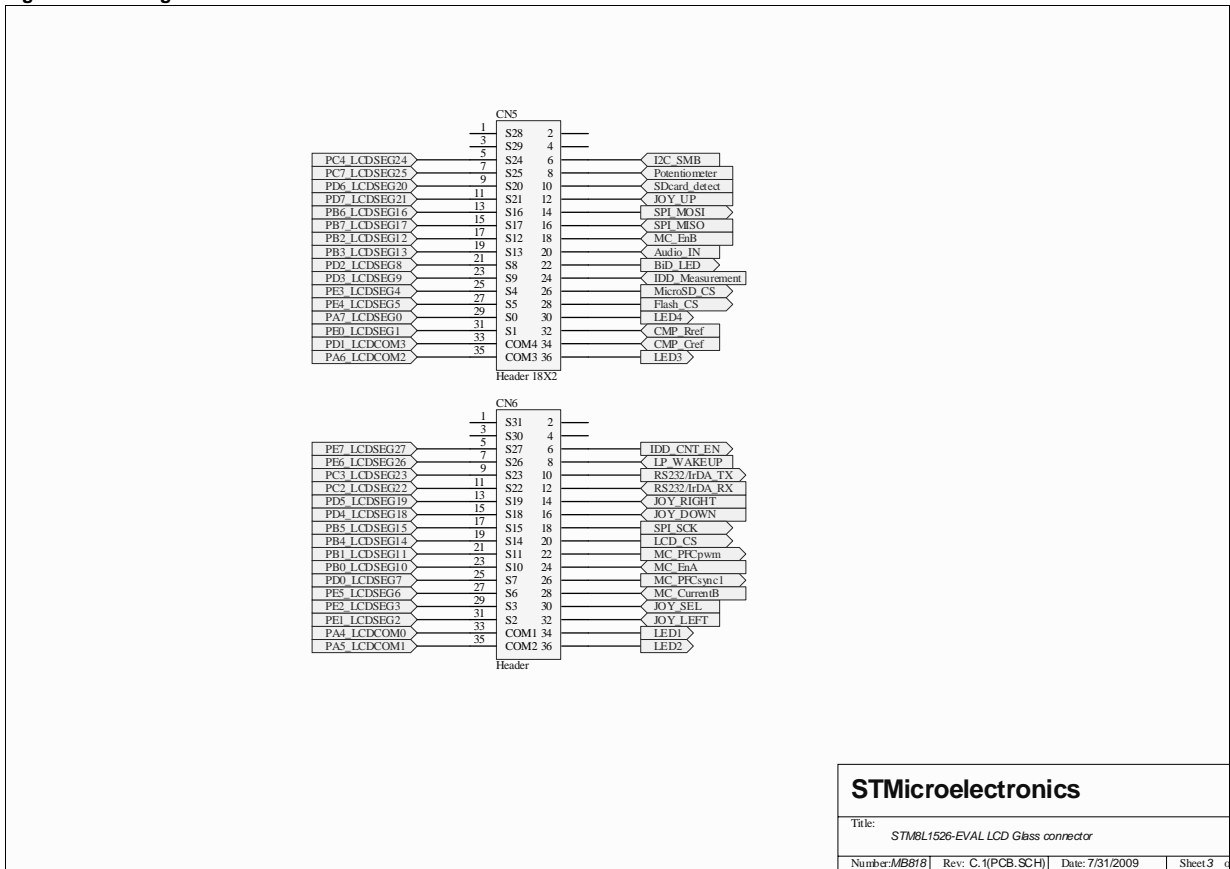

STMicroelectronics

Title: STM8L1526-EVAL LCD Glass connector

Number: MB818 | Rev: C.1(PCB.SCH) | Date: 7/31/2009 | Sheet 3 of 4



Figure 22. Audio

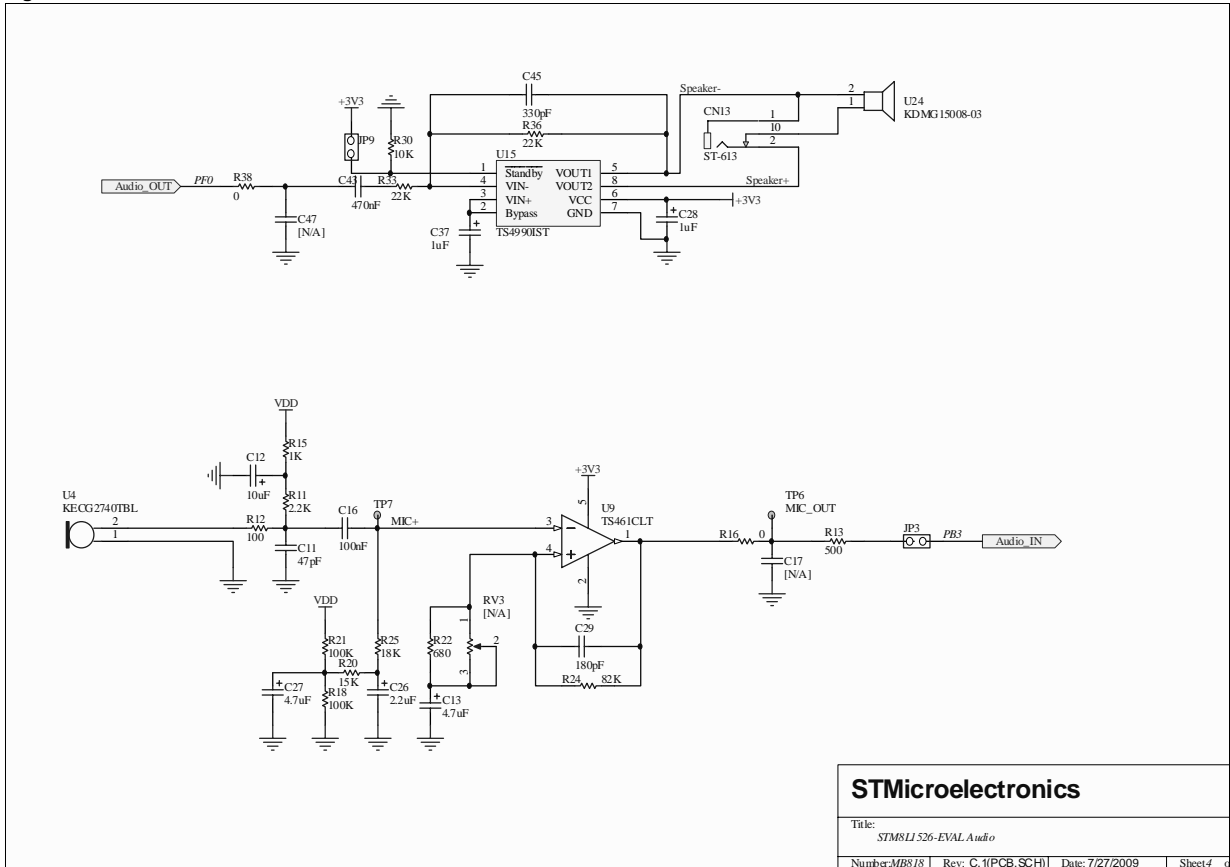

STMicroelectronics

Title:	STM8L1526-EVAL Audio		
Number	MBS18	Rev.	C.1(PCB.SCH)
Date:	7/27/2009	Sheet	4 of 4



Figure 23. Peripherals

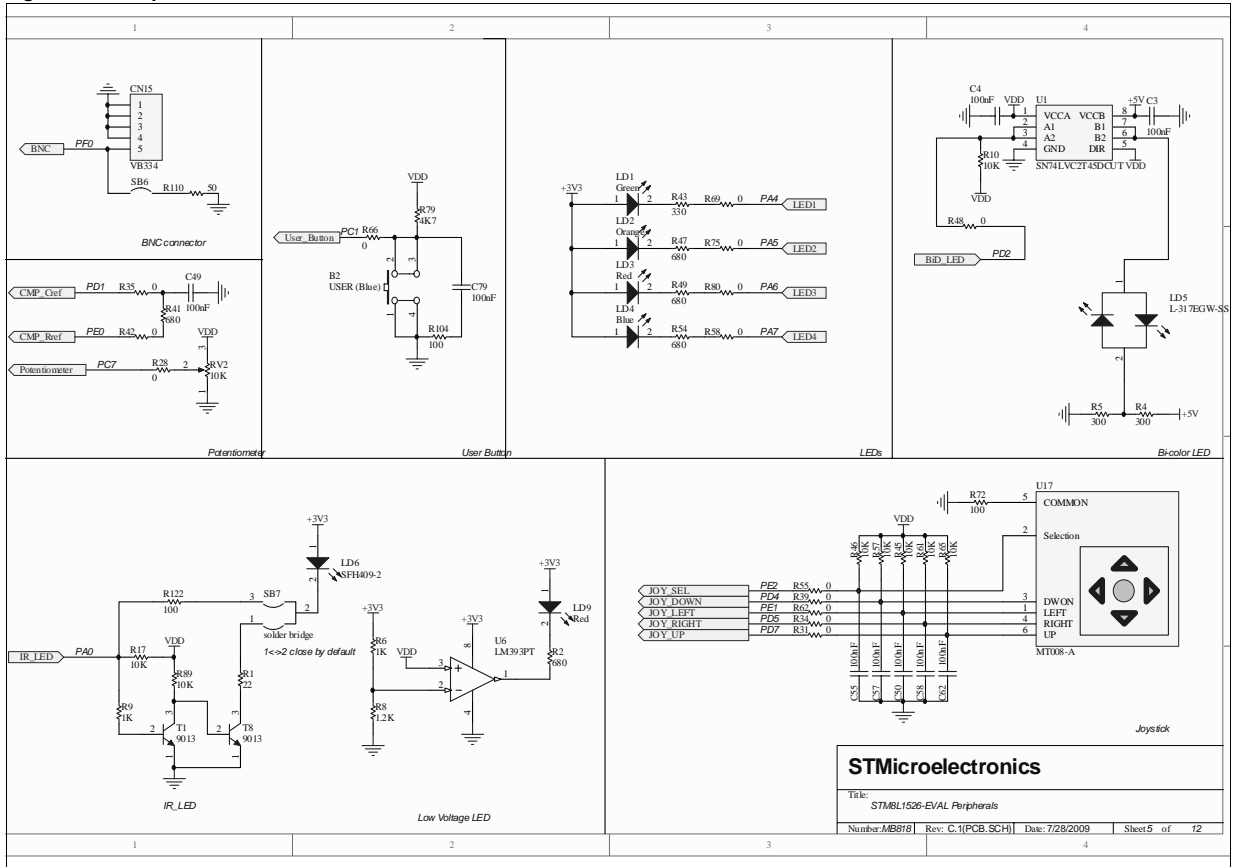

STMicroelectronics
 Title: STM8L1526-EVAL Peripherals
 Number: MB816 Rev. C.1(PCB, SCH) Date: 7/28/2009 Sheet 5 of 12



Figure 24. Power

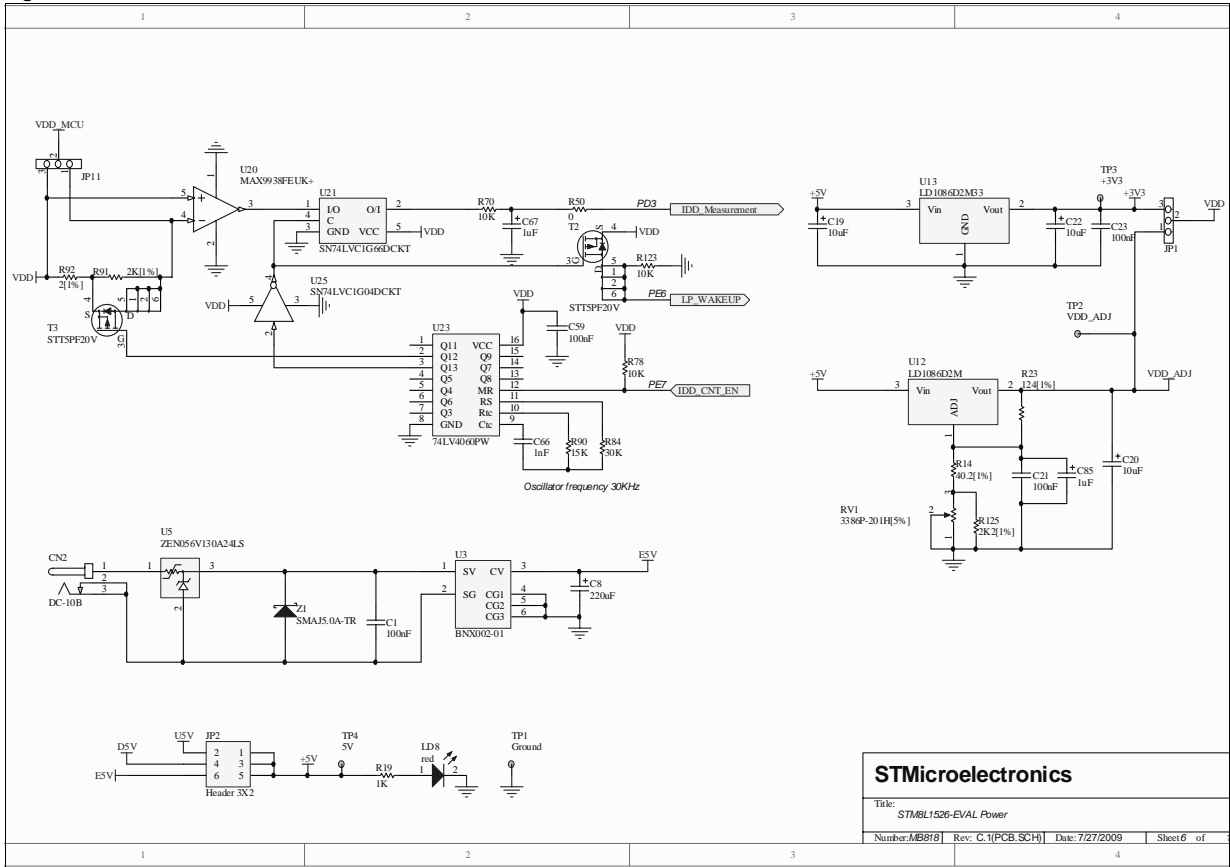
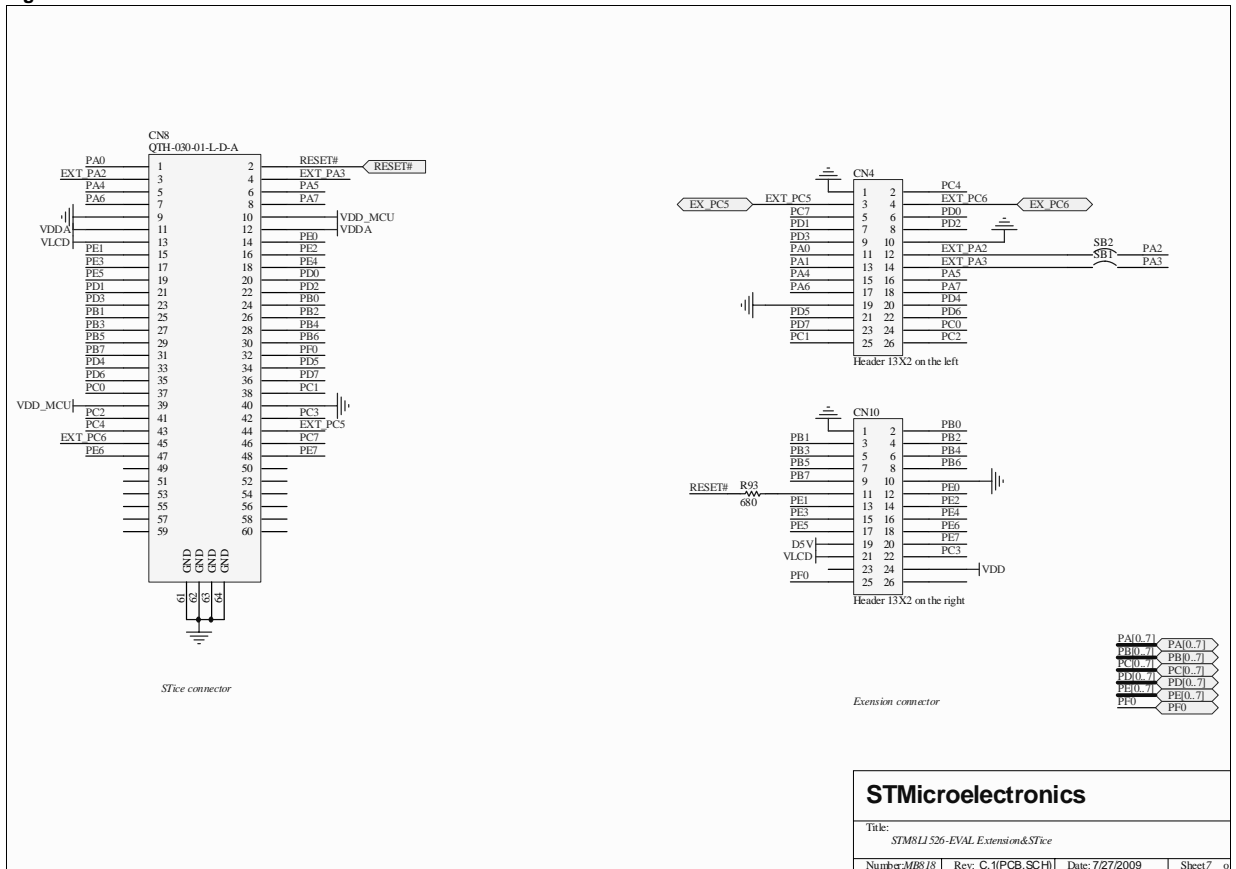

Figure 25. Extension and STice

36/46

Doc ID 15437 Rev 1



STMicroelectronics

Title: STM8L1526-EVAL Extension&STice

Number: MB818 | Rev: C.1(PCB.SCH) | Date: 7/27/2009 | Sheet 7 of 9



Figure 26. LCD and SD Card

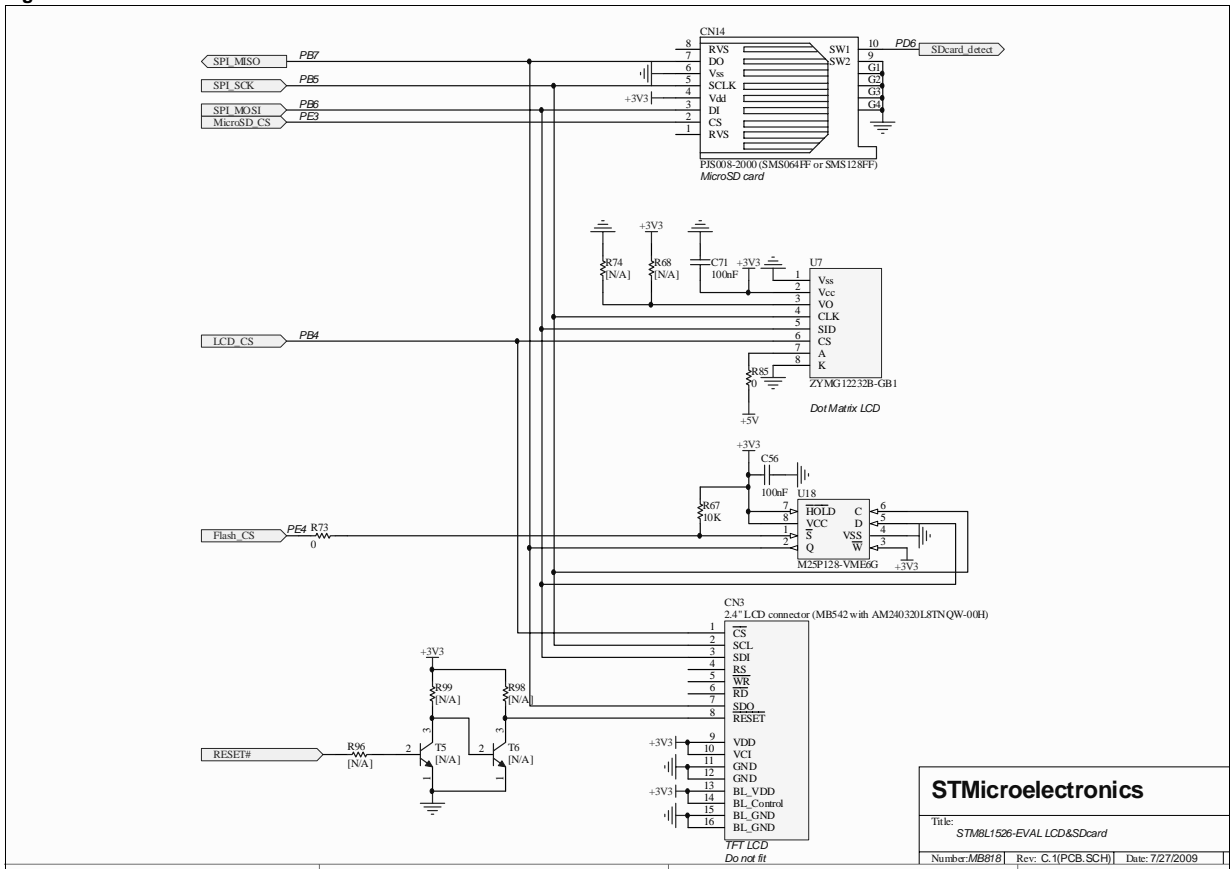
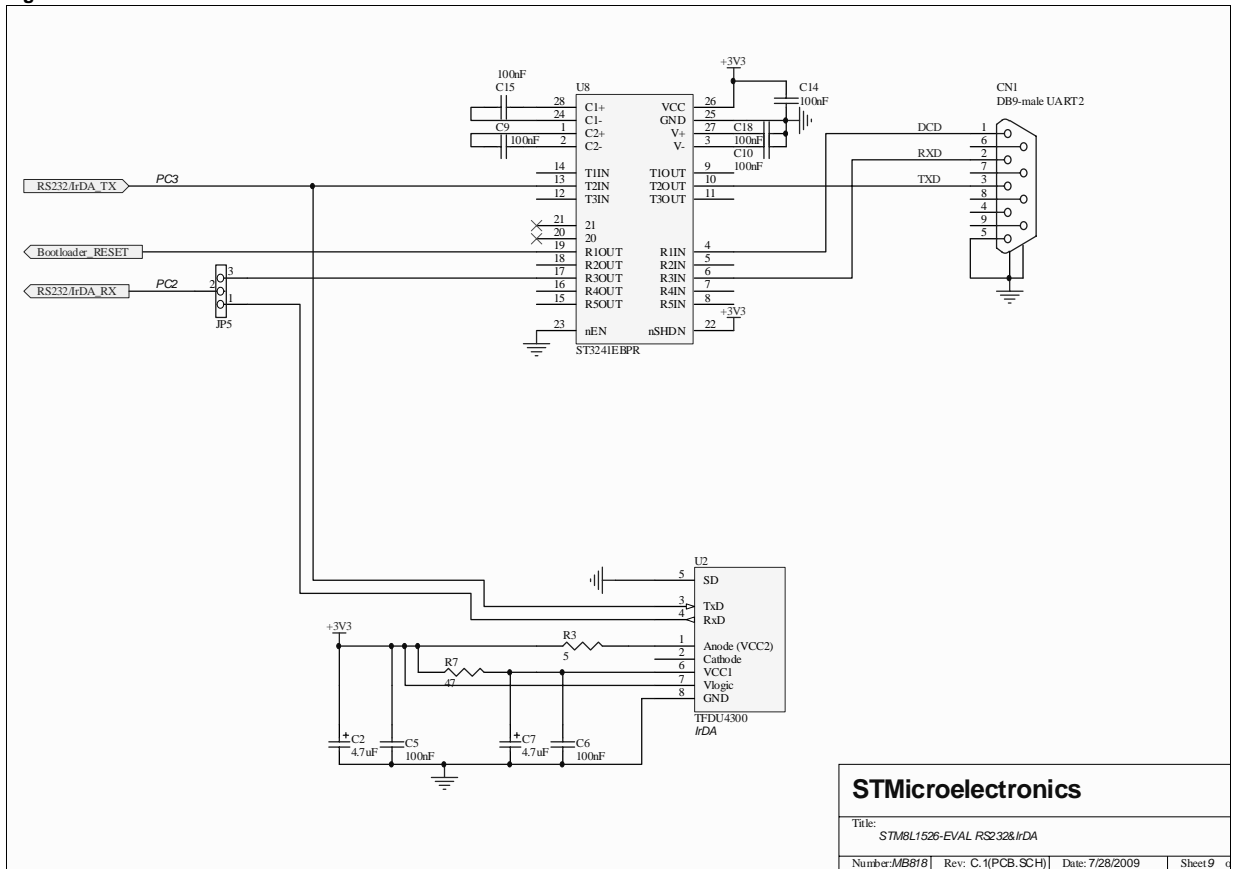



Figure 27. RS-232 and IrDA



STMicroelectronics			
Title: STM8L1526-EVAL RS232&IrDA			
Number: MB818	Rev: C.1(PCB.SCH)	Date: 7/28/2009	Sheet 9 / 9

Figure 29. EEPROM and temperature sensor

40/46

Doc ID 15437 Rev 1

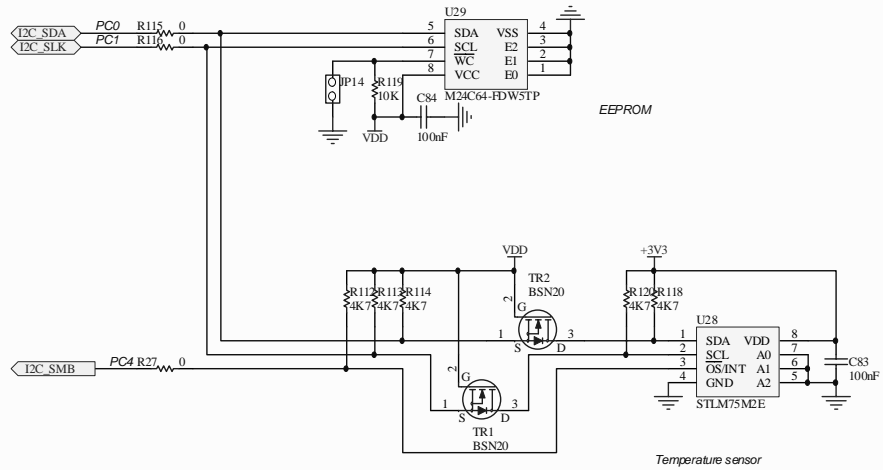

STMicroelectronics		
Title: STM8L1526-EVAL EEPROM&TemperatureSensor		
Number:MB818	Rev: C.1(PCB.SCH)	Date: 7/27/2009



Figure 30. ST_LINK (SWIM only)

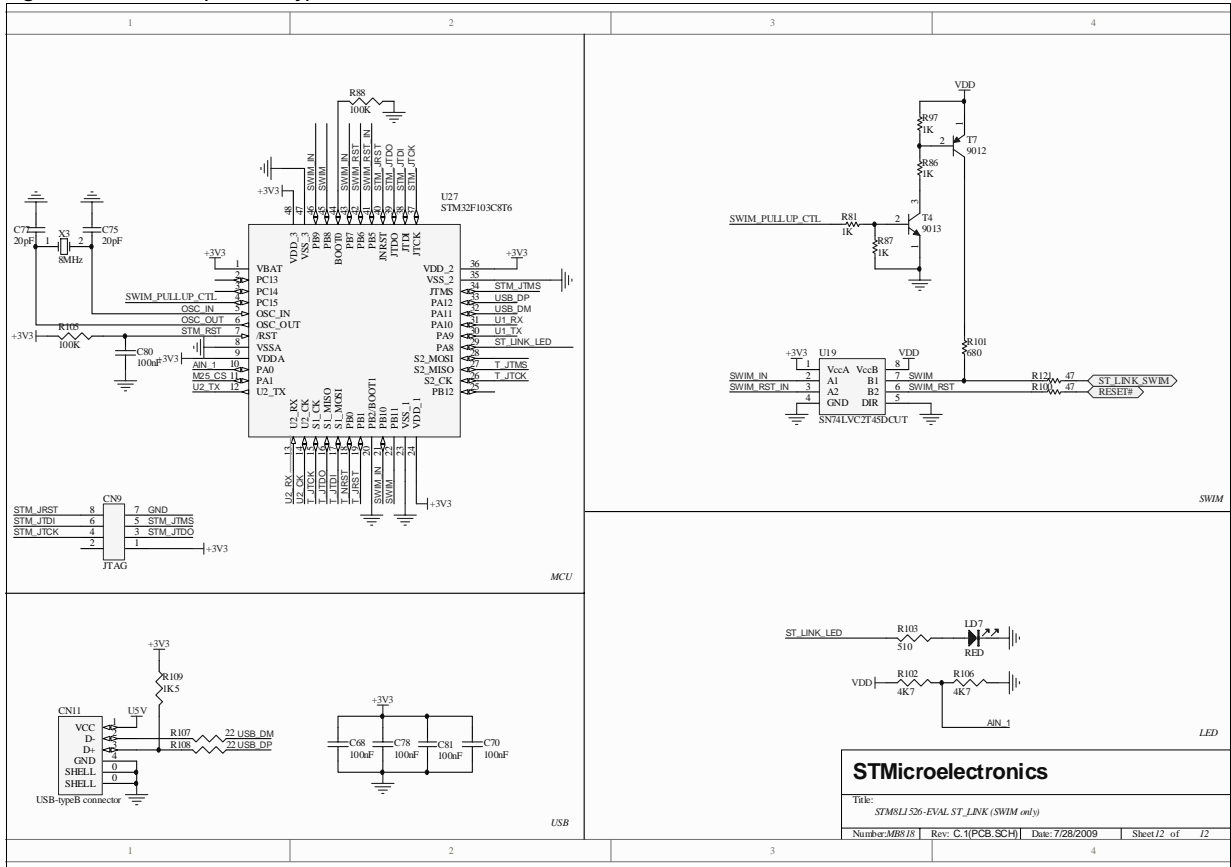

Doc ID 15437 Rev 1

41/46

STMicroelectronics			
Title: STM32L1526-EVAL_ST_LINK (SWIM only)			
Number: M8818	Rev: C:1(PCB_SCH)	Date: 7/28/2009	Sheet 12 of 12

Figure 31. MB821

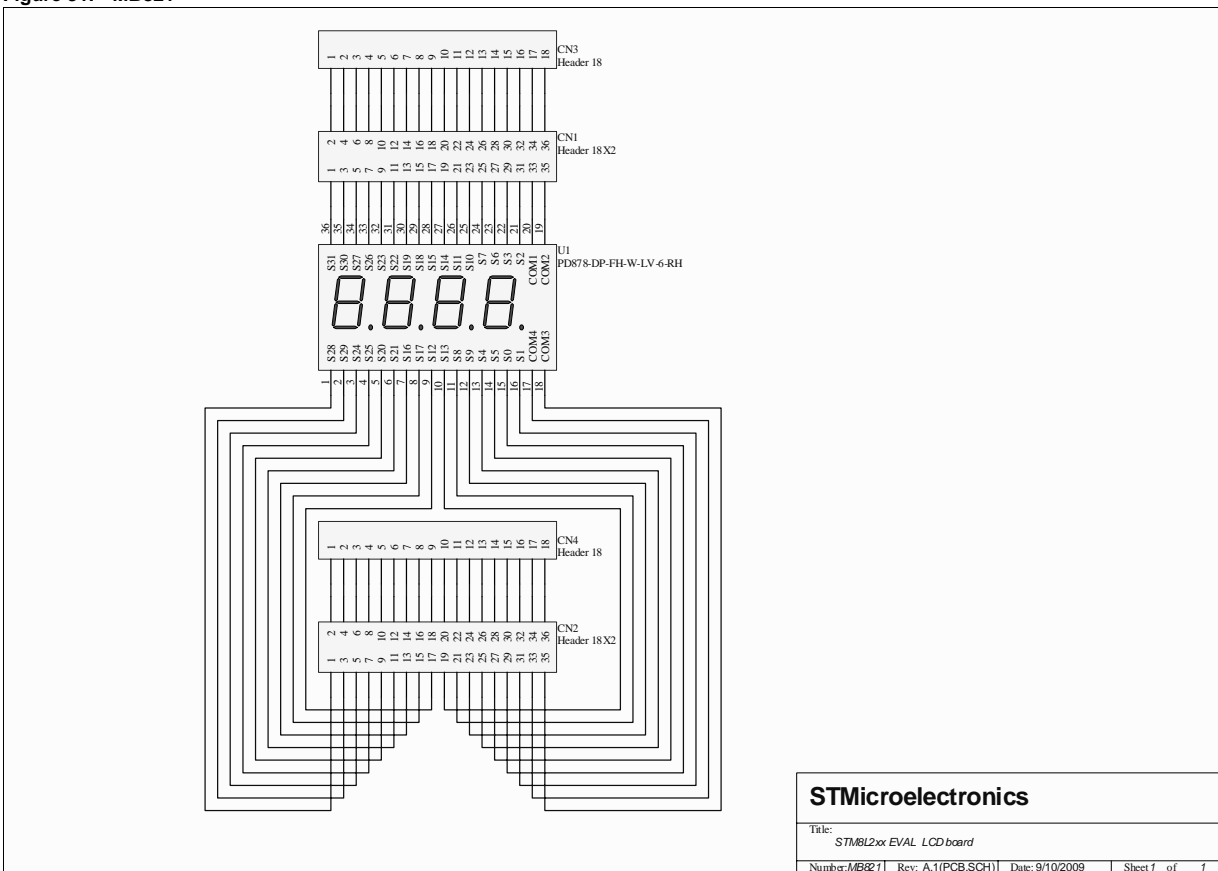

STMicroelectronics			
Title: STM8L2xx EVAL LCD board			
Number: MB821	Rev: A.1(PCB.SCH)	Date: 9/10/2009	Sheet 1 of 1



Appendix A STM8L1526-EVAL I/O assignment

Table 22. STM8L1526-EVAL I/O assignment

Pin No.	Pin name	STM8L1526-EVAL I/O assignment
1	PA0	SWIM / IR_LED
2	PA1	RESET button
3	PA2	16MHZ crystal
4	PA3	16MHZ crystal
5	PA4	LED1 / Motor control connector (Current A)
6	PA5	LED2 / Motor control connector (Bus voltage)
7	PA6	LED3 / Motor control connector (Current C)
8	PA7	LED4 / Motor control connector (Encoder index)
9	VSS	GND
10	VDD	VDD_MCU
11	VDDA	VDDA
12	VREF+	VDDA
13	VLCD	-
14	PE0	CMP_Rref / Motor control connector (NTC_bypass)
15	PE1	Joystick_Left / Motor control connector (MC_VL)
16	PE2	Joystick_sel / Motor control connector (MC_WL)
17	PE3	Micro SD card_CS
18	PE4	Serial Flash_CS
19	PE5	Motor control connector (Current B)
20	PD0	Motor control connector (PFC sync)
21	PD1	CMP_Cref / Motor control connector (PFC sync)
22	PD2	Bi-color_LED / Motor control connector (MC_UH)
23	PD3	IDD_Measurement
24	PB0	Motor control connector (Encoder A)
25	PB1	Motor control connector (Dissipative brake & PFC PWM)
26	PB2	Motor control connector (Encoder B)
27	PB3	Audio_ADC_IN / Motor control connector (Heatsink_temperature)
28	PB4	Dot-matrix LCD_CS
29	PB5	LCD_SDcard_Flash_SCK
30	PB6	LCD_SDcard_Flash_MOSI
31	PB7	LCD_SDcard_Flash_MISO
32	PF0	BNC / Audio_DAC_out

Table 22. STM8L1526-EVAL I/O assignment (continued)

Pin No.	Pin name	STM8L1526-EVAL I/O assignment
33	PD4	Joystick_down / Motor control connector (MC_VH)
34	PD5	Joystick_right / Motor control connector (MC_WH)
35	PD6	Motor control connector (EmergencySTOP) / SDcard_detect
36	PD7	Joystick_up / Motor control connector (MC_UL)
37	PC0	I ² C SDA
38	PC1	Key Button / I ² C SCL
39	VDDIO	VDD_MCU
40	VSSIO	GND
41	PC2	UART_IrDA_RX
42	PC3	UART_IrDA_TX
43	PC4	I ² C_SMB
44	PC5	32 kHz crystal
45	PC6	32 kHz crystal
46	PC7	Potentiometer
47	PE6	IDD_Measurement_Wakeup
48	PE7	IDD_Measurement_CNT_EN

Note: All I/O's marked in grey are shared with LCD glass module.

Revision history

Table 23. Document revision history

Date	Revision	Changes
10-Sep-2009	1	Initial release.

Please Read Carefully:

Information in this document is provided solely in connection with ST products. STMicroelectronics NV and its subsidiaries ("ST") reserve the right to make changes, corrections, modifications or improvements, to this document, and the products and services described herein at any time, without notice.

All ST products are sold pursuant to ST's terms and conditions of sale.

Purchasers are solely responsible for the choice, selection and use of the ST products and services described herein, and ST assumes no liability whatsoever relating to the choice, selection or use of the ST products and services described herein.

No license, express or implied, by estoppel or otherwise, to any intellectual property rights is granted under this document. If any part of this document refers to any third party products or services it shall not be deemed a license grant by ST for the use of such third party products or services, or any intellectual property contained therein or considered as a warranty covering the use in any manner whatsoever of such third party products or services or any intellectual property contained therein.

UNLESS OTHERWISE SET FORTH IN ST'S TERMS AND CONDITIONS OF SALE ST DISCLAIMS ANY EXPRESS OR IMPLIED WARRANTY WITH RESPECT TO THE USE AND/OR SALE OF ST PRODUCTS INCLUDING WITHOUT LIMITATION IMPLIED WARRANTIES OF MERCHANTABILITY, FITNESS FOR A PARTICULAR PURPOSE (AND THEIR EQUIVALENTS UNDER THE LAWS OF ANY JURISDICTION), OR INFRINGEMENT OF ANY PATENT, COPYRIGHT OR OTHER INTELLECTUAL PROPERTY RIGHT.

UNLESS EXPRESSLY APPROVED IN WRITING BY AN AUTHORIZED ST REPRESENTATIVE, ST PRODUCTS ARE NOT RECOMMENDED, AUTHORIZED OR WARRANTED FOR USE IN MILITARY, AIR CRAFT, SPACE, LIFE SAVING, OR LIFE SUSTAINING APPLICATIONS, NOR IN PRODUCTS OR SYSTEMS WHERE FAILURE OR MALFUNCTION MAY RESULT IN PERSONAL INJURY, DEATH, OR SEVERE PROPERTY OR ENVIRONMENTAL DAMAGE. ST PRODUCTS WHICH ARE NOT SPECIFIED AS "AUTOMOTIVE GRADE" MAY ONLY BE USED IN AUTOMOTIVE APPLICATIONS AT USER'S OWN RISK.

Resale of ST products with provisions different from the statements and/or technical features set forth in this document shall immediately void any warranty granted by ST for the ST product or service described herein and shall not create or extend in any manner whatsoever, any liability of ST.

ST and the ST logo are trademarks or registered trademarks of ST in various countries.

Information in this document supersedes and replaces all information previously supplied.

The ST logo is a registered trademark of STMicroelectronics. All other names are the property of their respective owners.

© 2009 STMicroelectronics - All rights reserved

STMicroelectronics group of companies

Australia - Belgium - Brazil - Canada - China - Czech Republic - Finland - France - Germany - Hong Kong - India - Israel - Italy - Japan - Malaysia - Malta - Morocco - Philippines - Singapore - Spain - Sweden - Switzerland - United Kingdom - United States of America

www.st.com