

### Introduction

The STM8L101-EVAL is composed of two boards:

- An STM8L1/L2 motherboard called MB709 which includes all peripherals which are connected to the MCU on the daughterboard. The motherboard connects to the daughterboard via two 36-pin connectors.
- An STM8L1 daughterboard called MB710 which has an STM8L101 MCU.

The motherboard and daughterboard are a complete development platform for STMicroelectronics' STM8L101 microcontroller with comparator, I2C, SPI, USART and SWIM debugging support.

The full range of hardware features on the STM8L101-EVAL helps you to evaluate all peripherals (MicroSD card™, USART, EEPROM, LCD, for example) and develop your own applications.

**Figure 1. STM8L101-EVAL board**

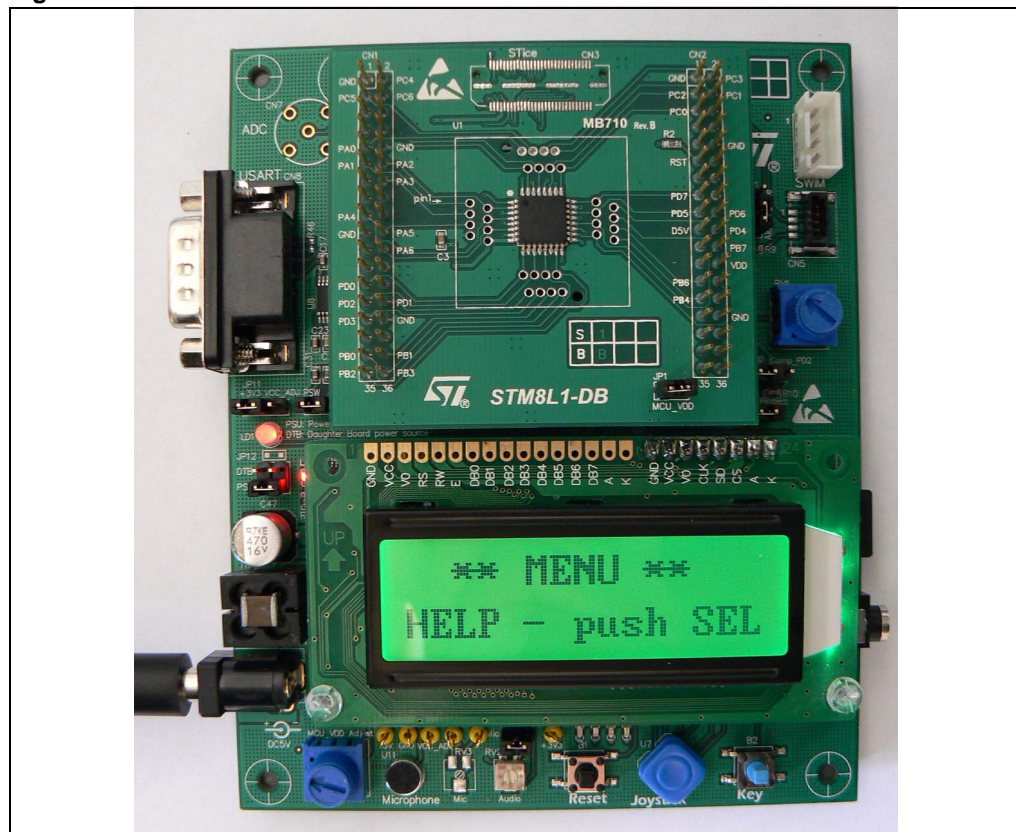

# Contents

<b>1</b>	<b>Overview</b>	<b>4</b>
1.1	Features	4
1.2	Demonstration software	4
1.3	Order code	4
1.4	Hardware layout and configuration	5
<b>2</b>	<b>STM8L1/L2 motherboard</b>	<b>8</b>
2.1	Power supply	8
2.2	Reset source	9
2.3	Audio	9
2.4	I2C EEPROM	10
2.5	RS-232	10
2.6	MicroSD card	10
2.7	Analog input	10
2.8	Development and debug support CN5 and CN6	10
2.9	Display and input devices	11
2.10	Bi-color LED	11
2.11	Economic measurement and potentiometer RV1	11
2.12	MicroSD connector CN1	12
2.13	Daughterboard extension connectors CN3 and CN4	13
2.14	SWIM connectors CN5 and CN6	14
2.15	RS-232 connector CN8	15
2.16	Audio jack CN9	15
2.17	Power connector CN10	15
<b>3</b>	<b>STM8L1 daughterboard</b>	<b>16</b>
3.1	Power	16
3.2	Extension connector CN1 and CN2	16
<b>4</b>	<b>Schematics</b>	<b>17</b>
4.1	STM8L1/L2 motherboard	17
4.2	STM8L1-DB daughterboard schematic	23

---

Appendix A	STM8L101-EVAL I/O assignment .....	24
5	Revision history .....	25

# 1 Overview

## 1.1 Features

- 5 V power jack supply
- Audio play
- MicroSD card™
- 64 Kbit I2C EEPROM
- One channel of RS-232 communication
- Bi-color LED
- Economic analog voltage measurement based on comparator
- SWIM debug support
- 122 x 32 dot-matrix serial interface LCD module
- Joystick with 4-direction control and selector
- Reset and User button
- 3 LEDs
- Extension connector for daughterboard
- One 10 K potentiometer
- RoHS compliant

## 1.2 Demonstration software

Demonstration software is preloaded in the board's Flash memory for easy demonstration of device peripherals in stand-alone mode. For more information and to download the latest version available, refer to STM8L101-EVAL demonstration firmware available on web: [www.st.com/mcu](http://www.st.com/mcu).

## 1.3 Order code

To order the STM8L101K3 evaluation board, use the order code STM8L101-EVAL.

## 1.4 Hardware layout and configuration

The STM8L101-EVAL evaluation board is designed around the STM8L101K3T6 in an LQFP32 package.

*Figure 2* illustrates the connections between the daughterboard and the peripherals on the motherboard (LCD, I2C EEPROM, USART, audio and MicroSD card).

*Figure 3* and *Figure 4* help you to locate these features on the actual evaluation board.

**Figure 2. Hardware block diagram**

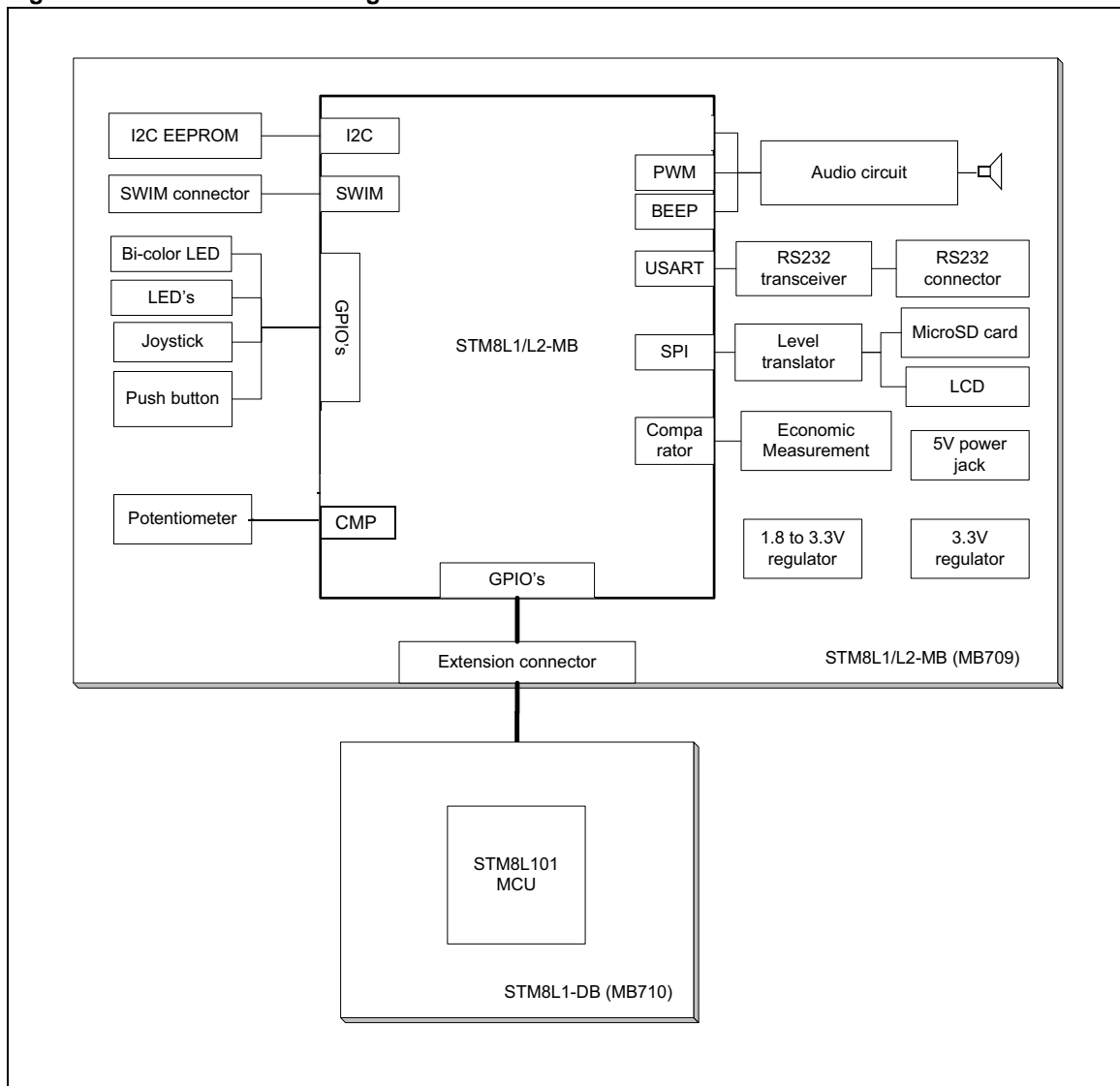

Figure 3. STM8L1/L2 motherboard layout

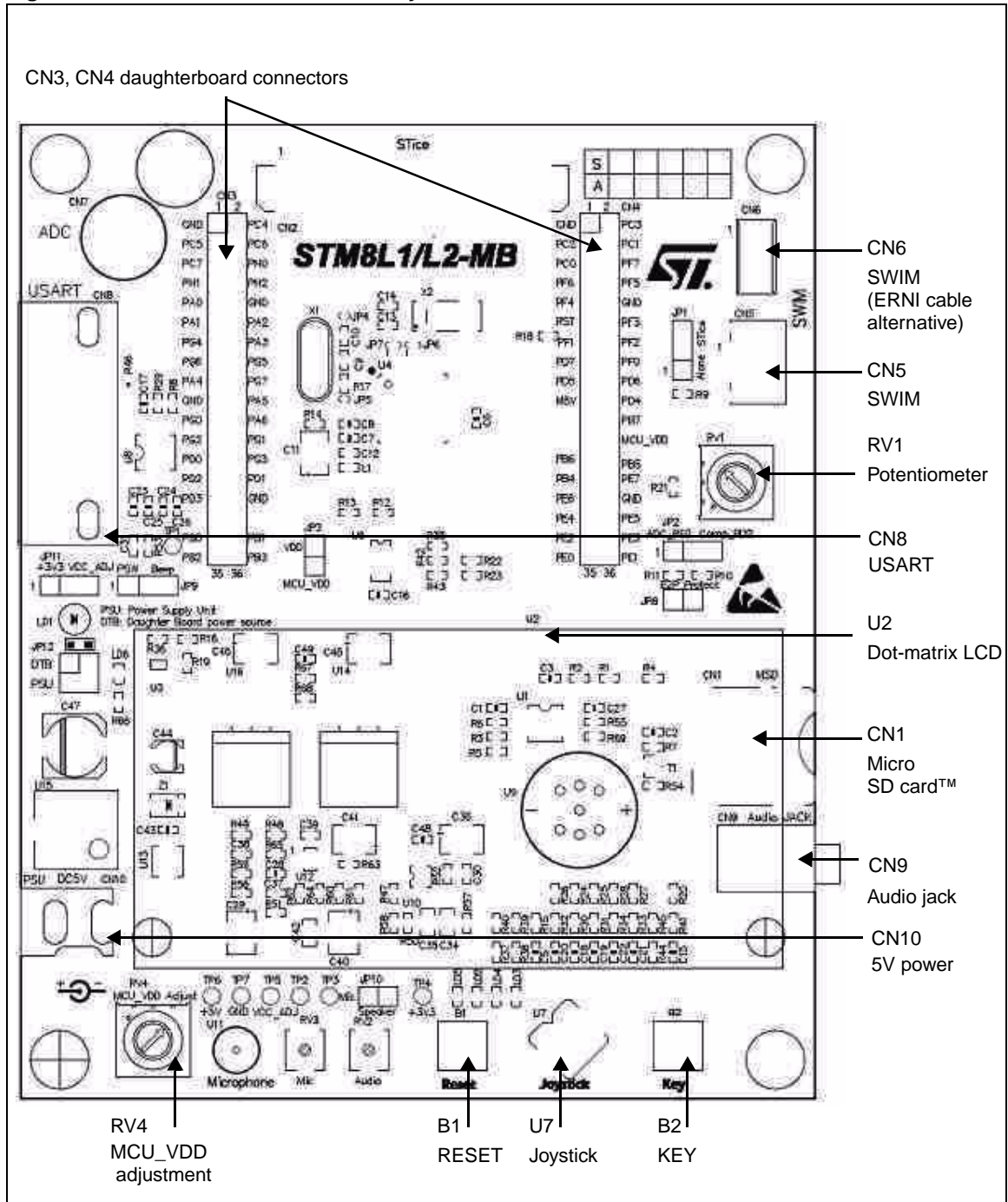
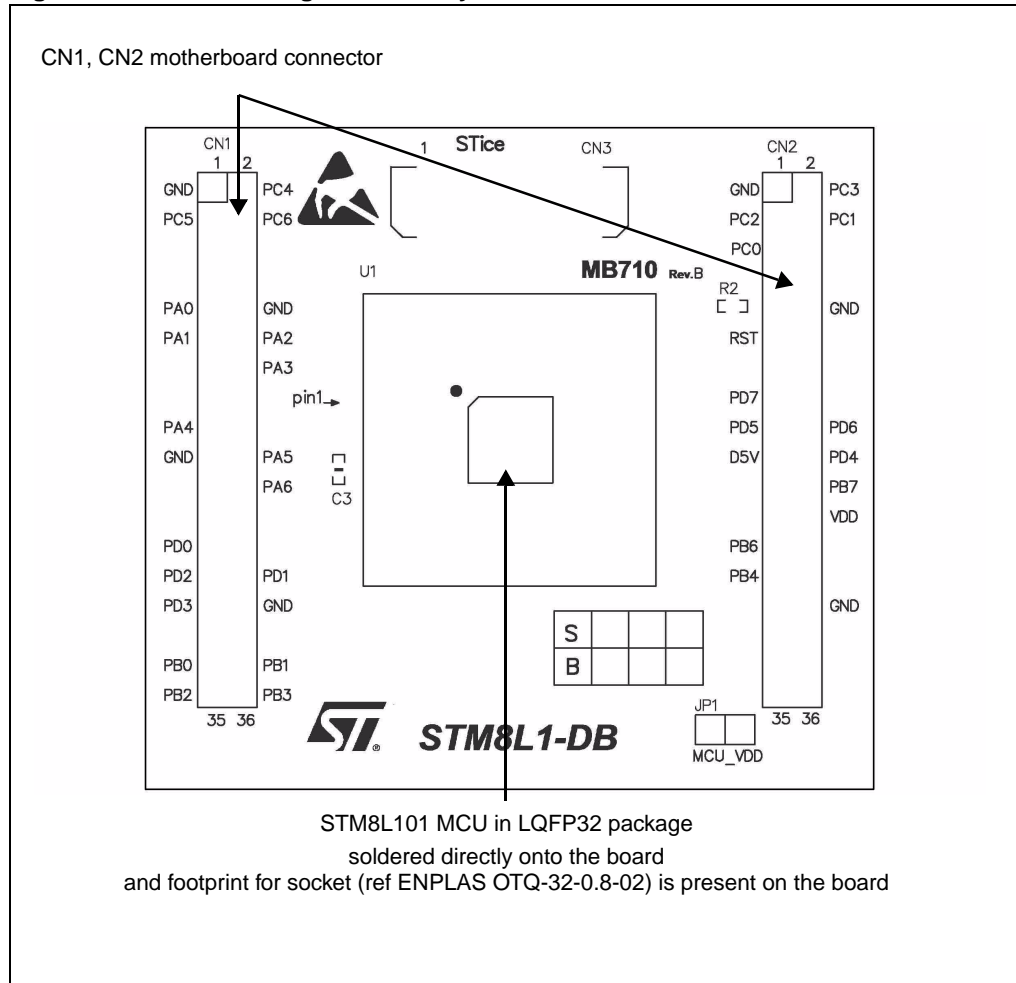

Figure 4. STM8L1 daughterboard layout



## 2 STM8L1/L2 motherboard

This motherboard is designed to work with an STM8L1 daughterboard.

### 2.1 Power supply



The motherboard is designed to be powered by a 5 V DC power supply and to be protected from a wrong power plug-in event by PolyZen Inc. (auto rearmable fuse) U13. It is possible to configure the evaluation board to provide 5 V power to the daughterboard through the daughterboard connector.

- The motherboard is powered by a 5 V DC power adapter connected to CN10, the power jack on the board (PSU on silk screen for power supply unit).
- 5 V DC power is provided to the daughterboard through an extension connector and can be set by jumper JP12 (DTB for daughterboard on silk-screen).
- MCU\_VDD can be selected by setting jumper JP11 and is connected to the daughterboard directly through the daughterboard connector.

The power supply is configured by setting the jumpers JP11 and JP12 as described in [Table 1](#).

The LED LD6 is lit when the motherboard is powered correctly. JP3 is no longer used.

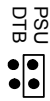
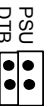
**Table 1. Power related jumpers**

Jumper	Description	Setting
JP12	5 V power from power supply jack (CN10) is connected to the motherboard when JP12 is set as shown to the right: (default setting).	 PSU DTB
	5 V power from power supply jack (CN10) is connected to the daughterboard when JP12 is set as shown to the right: In this case the motherboard and daughterboard are powered by a 5 V power supply.	 DTB PSU
JP11	MCU_VDD is powered by a fixed 3.3 V power supply when JP11 is set as shown to the right: (default setting).	 1
	MCU_VDD is powered by a variable power supply from 1.8 V to 3.3 V, adjusted by potentiometer RV4 (bottom left of the board), when JP11 is set as shown to the right:	 1





## 2.2 Reset source

The reset signal of the motherboard is low active. Reset sources include:

- Reset button B1.
- Debugging tools from connectors CN5, CN6.

The reset pin PA1 of the STM8L101 is either connected to the reset button B1 or to GND by the setting of jumper JP1:

**Table 2. Reset related jumpers**



Jumper	Description	Setting
JP1	PA1 is connected to GND when JP1 is set as shown to the right: This configuration is reserved for internal use only.	
	PA1 is connected to Reset button when JP1 is set as shown to the right: (default setting). This jumper position is called Alone on the silk-screen.	

## 2.3 Audio

The motherboard supports both audio recording and playback, but audio recording components (U11 microphone and U12 amplifier) cannot be used with the STM8L101. The speaker can be disabled or enabled by the setting of jumper JP10.

Audio volume can be adjusted using the potentiometer RV2.

**Table 3. Audio related jumpers**

Jumper	Description	Setting
JP10	Audio power amplifier TS4871 is forced on standby mode when JP10 is not fitted. Default setting: fitted.	
JP9	Either beeper or PWM output can be selected as a source of speaker by setting jumper JP9.	
	The beeper is connected to speaker when JP9 is set as shown to the right: (Beep position on the silk-screen). The PWM output is connected to speaker when JP9 is set as shown to the right: (PSW position on the silk-screen) (default setting).	 

## 2.4 I2C EEPROM

A 64 Kbit I2C EEPROM is connected to the I2C port of the STM8L101.

Write protection can be enabled by the setting of jumper JP8.

**Table 4. I2C EEPROM related jumpers**

Jumper	Description
JP8	I2C EEPROM U6 is protected from write operation when JP8 is not fitted. Default setting: Fitted

## 2.5 RS-232

One D-type 9-pin RS-232 connector CN8 is available on the motherboard.

RS-232 interface behavior is not guaranteed when the MCU is powered by an adjustable voltage lower than 3 V.

*Note:* To communicate with an RS-232 port on a PC, a 9-pin straight RS-232 cable (direct pin to pin connection) is needed because:

- On CN8 the RX signal is connected on pin2 and the TX data on pin 3,
- On the PC side the RX signal is generally on pin 3 and the TX signal on pin 2.

This standard 9-pin straight RS-232 cable is not provided with the board. Refer to [Section 2.15](#) for details on RS-232 connector pinout.

## 2.6 MicroSD card

The 1GByte (or more) MicroSD card connected to the SPI of the STM8L101 through a voltage level translator U1 (shared with LCD) is available on the board. MicroSD card chip select is managed by standard I/O port PB4.

## 2.7 Analog input

The BNC connector footprint present on the board (CN7) cannot be used as it is not connected to the MCU.

## 2.8 Development and debug support CN5 and CN6

The two debug connectors are available on the motherboard.

- CN5, ERNI 4-pin connector (reference 284697 or 214017) for SWIM debugging. It fits with ERNI connectors provided with standard tools.
- CN6, 2.54 mm pitch low-cost 4-pin connector for SWIM debugging.

## 2.9 Display and input devices

Display devices available are:

- 122x32 dot-matrix serial interface LCD (U2)
- 4 general purpose LED's (LD2,3,4,5)

Input devices available are:

- 4-direction joystick
- selection key
- general purpose button (B2)

**Table 5. 122x32 dot matrix LCD U13**

Pin on U2	Description	Pin connection
1	Vss	GND
2	Vcc	+3V3
3	VO	-
4	CLK	PB5
5	SID	PB6
6	CS	PD1
7	A	+5V
8	K	GND

## 2.10 Bi-color LED

A bi-color LED is connected to PB0 through a voltage translator which guarantees that the bi-color LED works when the STM8L101 is powered by an adjustable voltage from 1.8 V to 3.3 V.

## 2.11 Economic measurement and potentiometer RV1

The economic measurement solution is demonstrated based on the internal comparator inside the STM8L101 and potentiometer RV1.

As shown in [Figure 5](#), the voltage divided by resistor bridge R10 and R11 can be measured by using an internal comparator of the STM8L1, with Vref connected to channel 2 of the comparator and an RC charge circuit connected to the COM channel of the comparator.

To measure the voltage  $V_{in}$  from the potentiometer:

1. Compare Vref with the voltage on C8 which is charged by a series of pulses generated by PC4.
2. Record pulse number PN\_Vref when the voltage on C8 reaches voltage reference Vref.
3. Another charge pulse PN\_Vin can be obtained with voltage connected to CH1 also like PN\_Vref.
4. The voltage  $V_{in}$  can be calculated based on both numbers PN\_Vref and PN\_Vin.

Figure 5. Voltage measurement using internal comparator

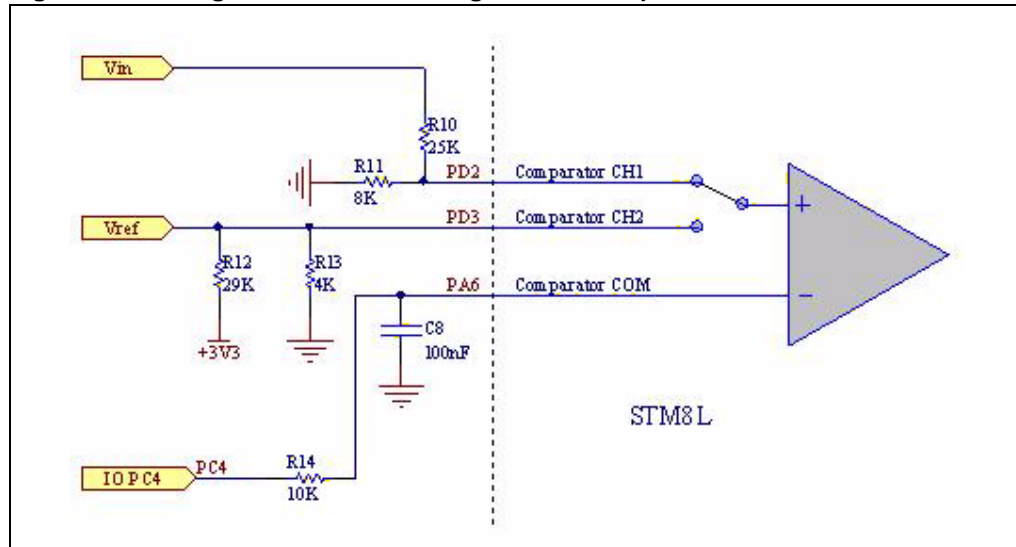
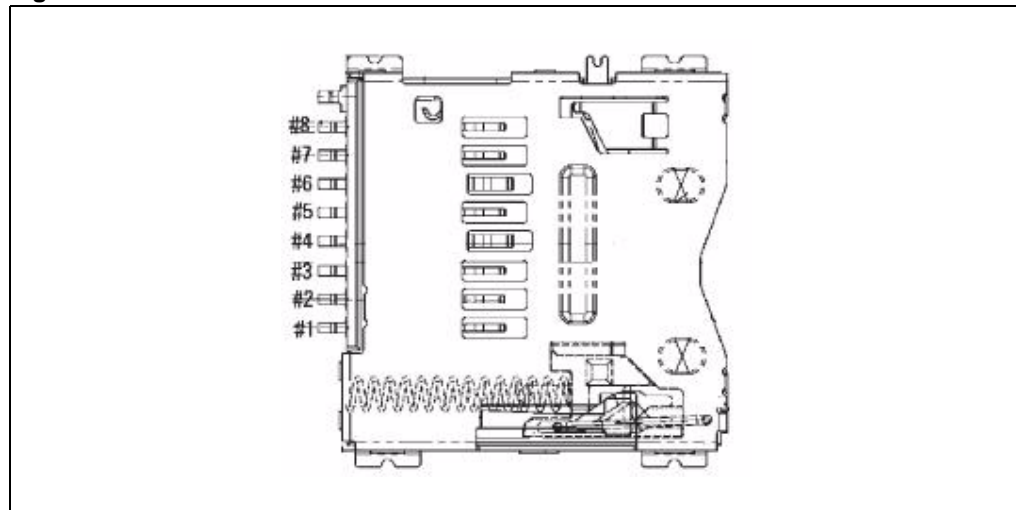

Table 6. Potentiometer RV1 related jumpers

Jumper	Description	Setting
JP2	RV1 is connected to PD2 as one input of the internal comparator when JP2 is set as shown to the right: JP2 position is called Comp_PD2 on the silk-screen.	
	RV1 is not connected when JP2 is set as shown to the right: (default setting). JP2 position is called ADC_PE0 on the silk-screen.	

## 2.12 MicroSD connector CN1

Figure 6. MicroSD connector CN1 viewed from front



**Table 7. MicroSD connector CN1**

Pin number	Description	Pin number	Description
1	Reserved	5	SCLK/PB5
2	CS/PB4	6	Vss/GND
3	DI/PB6	7	DO/PB7
4	VDD	8	Reserved
9	GND	10	Not used

## 2.13 Daughterboard extension connectors CN3 and CN4

Two 36-pin male headers CN3 and CN4 can be used to connect the daughterboard to the motherboard. All GPI/Os are available on it. Please refer to [Table 8](#) and [Table 9](#) for pin-out definition.

**Table 8. Daughterboard extension connector CN3**

Pin number	Description	Pin number	Description
1	GND	2	PC4
3	PC5	4	PC6
5	Reserved	6	Reserved
7	Reserved	8	Reserved
9	PA0	10	GND
11	PA1	12	PA2
13	Reserved	14	PA3
15	Reserved	16	Reserved
17	PA4	18	Reserved
19	GND	20	PA5
21	Reserved	22	PA6
23	Reserved	24	Reserved
25	PD0	26	Reserved
27	PD2	28	PD1
29	PD3	30	GND
31	NC	32	NC
33	PB0	34	PB1
35	PB2	36	PB3

**Table 9. Daughterboard extension connector CN4**

Pin number	Description	Pin number	Description
1	GND	2	PC3
3	PC2	4	PC1
5	PC0	6	Reserved
7	Reserved	8	Reserved
9	Reserved	10	GND
11	RESET#	12	Reserved
13	Reserved	14	Reserved
15	PD7	16	Reserved
17	PD5	18	PD6
19	D5V	20	PD4
21	NC	22	PB7
23	NC	24	MCU_VDD
25	PB6	26	PB5
27	PB4	28	Reserved
29	Reserved	30	GND
31	Reserved	32	Reserved
33	Reserved	34	Reserved
35	Reserved	36	Reserved

## 2.14 SWIM connectors CN5 and CN6

CN6 is a low cost 2.54 mm pitch connector to be used by customers who do not have the ERNI cable.

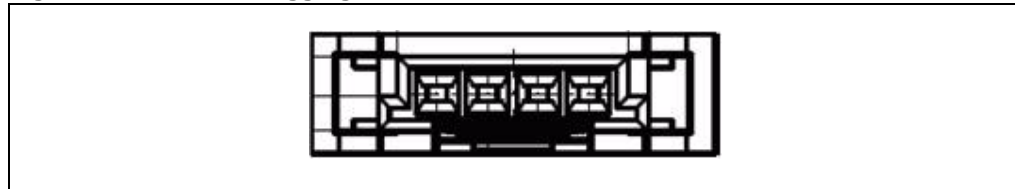
**Figure 7. SWIM debugging connector CN5 viewed from above PCB****Table 10. SWIM debugging connectors CN5 and CN6**

Pin number	Description	Pin number	Description
1	VDD	2	PA0
3	GND	4	RESET#

## 2.15 RS-232 connector CN8

Figure 8. RS-232 connector CN8 viewed from front

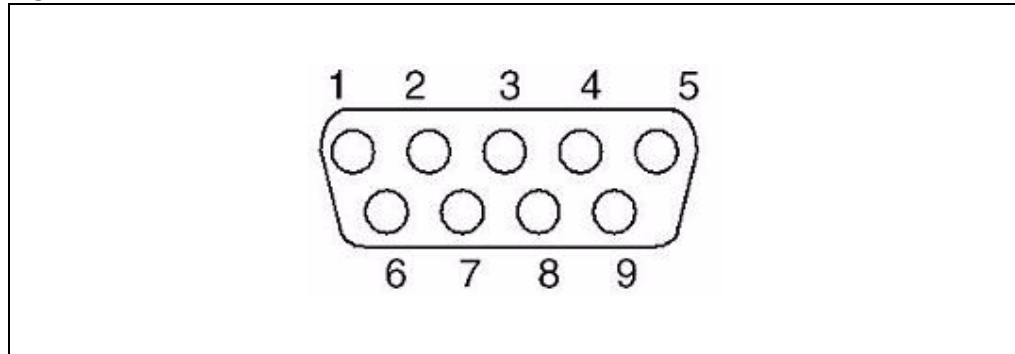

Table 11. RS-232 connector CN8

Pin number	Description	Pin number	Description
1	NC	6	Connect to Pin 4
2	USART_RXD/PC2	7	Connect to Pin 8
3	USART_TXD/PC3	8	Connect to Pin 7
4	Connect to Pin 6	9	NC
5	GND		

## 2.16 Audio jack CN9

A 3.5 mm mono audio jack CN9 is available on the motherboard. The speaker U9 is bypassed when an earphone is plugged into CN9 (CN9 is compatible with audio plug NYS231 from NEUTRIK).

## 2.17 Power connector CN10

The motherboard can be powered from a DC 5 V power supply via the external power supply jack CN10 shown in [Figure 9](#). The central pin of CN10 must be positive.

Figure 9. Power supply connector CN10 viewed from front

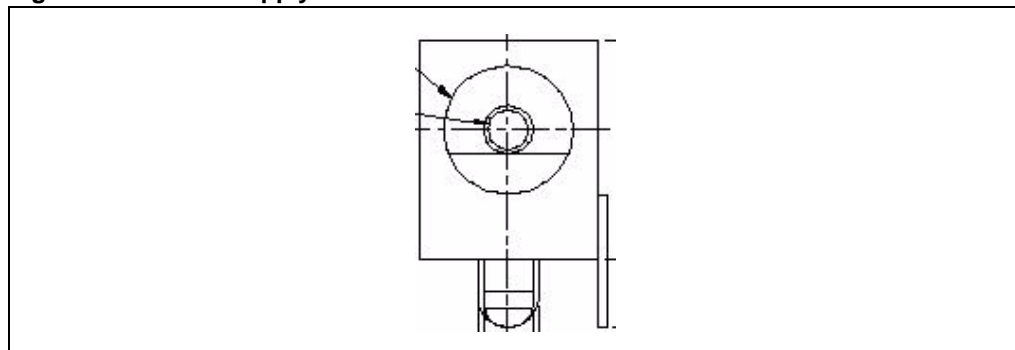

## 3 STM8L1 daughterboard

### 3.1 Power

The STM8L101 MCU is powered by MCU\_VDD from the motherboard through an extension connector on the board. It is enabled by setting the jumper JP1 as described in [Table 12](#).

**Table 12. Power related jumper\***

Jumper	Description
JP1	Enables consumption measurement of VDD when the jumper is removed and replaced by an ammeter. Default setting: Fitted.

### 3.2 Extension connector CN1 and CN2

The 36-pin connectors CN1 and CN2 are designed to be connected to the motherboard. The pin-out definition is the same as CN3 and CN4 on the motherboard which is described in [Section 2.13](#).

---

**Warning:** On MB710 PCB rev B, CN2 (pin 26) silk-screen PB5 is missing

---



## 4 Schematics

### 4.1 STM8L1/L2 motherboard

Figure 10. STM8L1 motherboard schematic

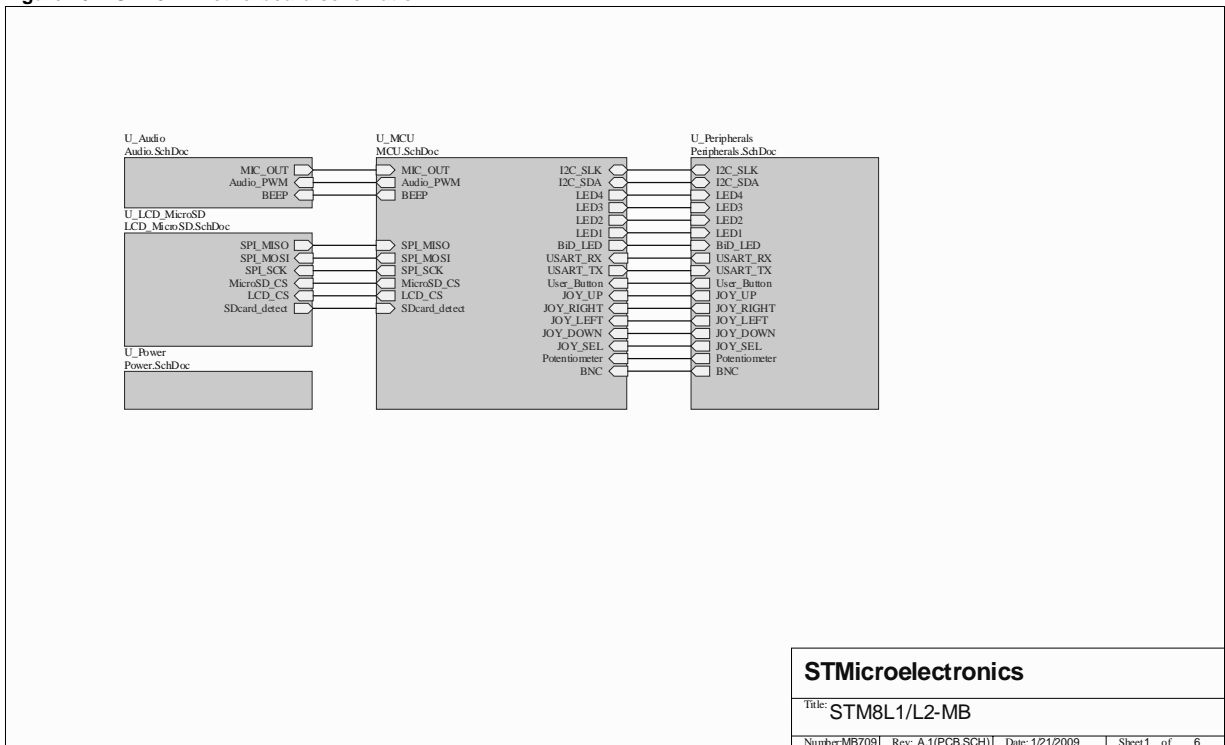

**STMicroelectronics**

Title: STM8L1/L2-MB

Number: MB709 | Rev: A.1(PCB.SCH1) | Date: 1/21/2009 | Sheet 1 of 6

Figure 11. STM8L1 motherboard MCU

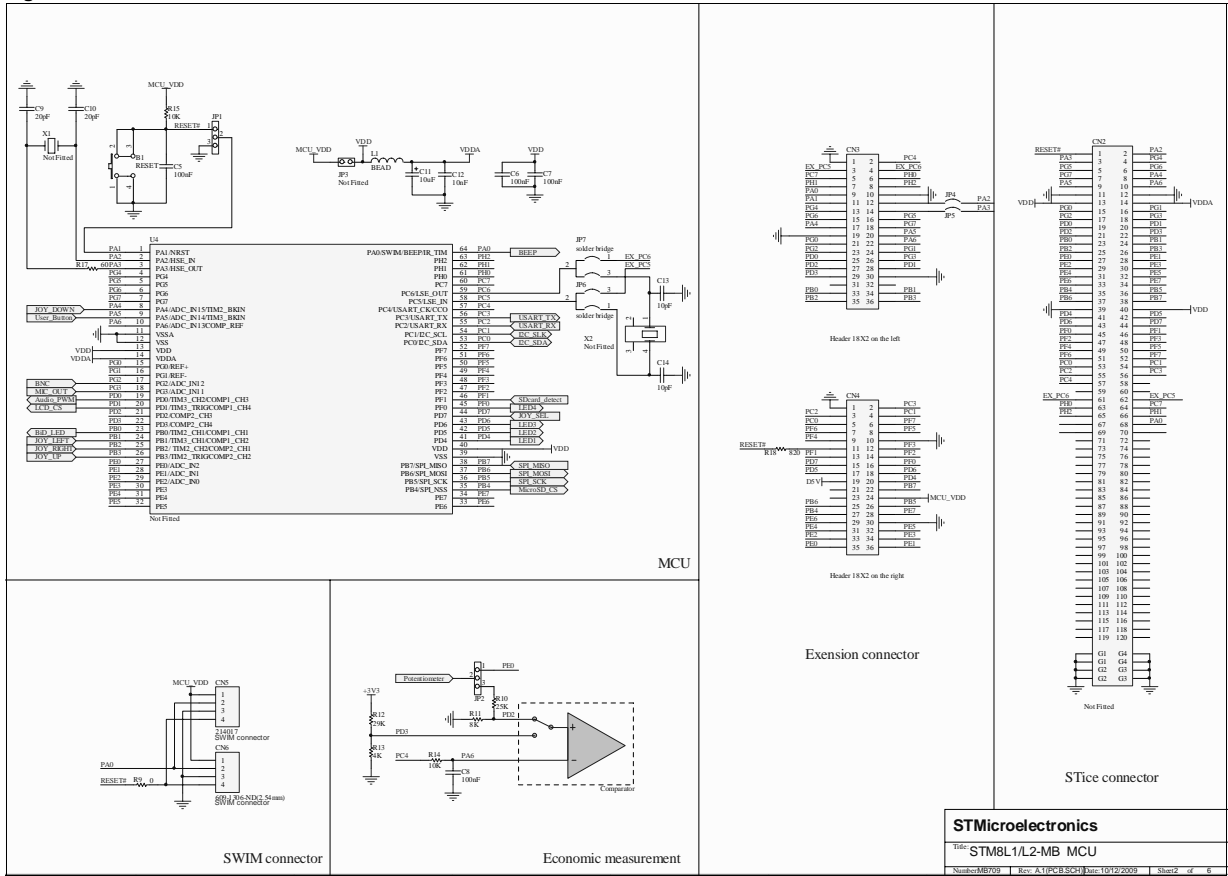

**STMicroelectronics**  
**STM8L1/L2-MB MCU**  
 Number: MB709 | Rev: A1 (P0-B365) | Rev: 01/2/2009 | Sheet 2 of 6





Figure 13. STM8L1 motherboard peripherals

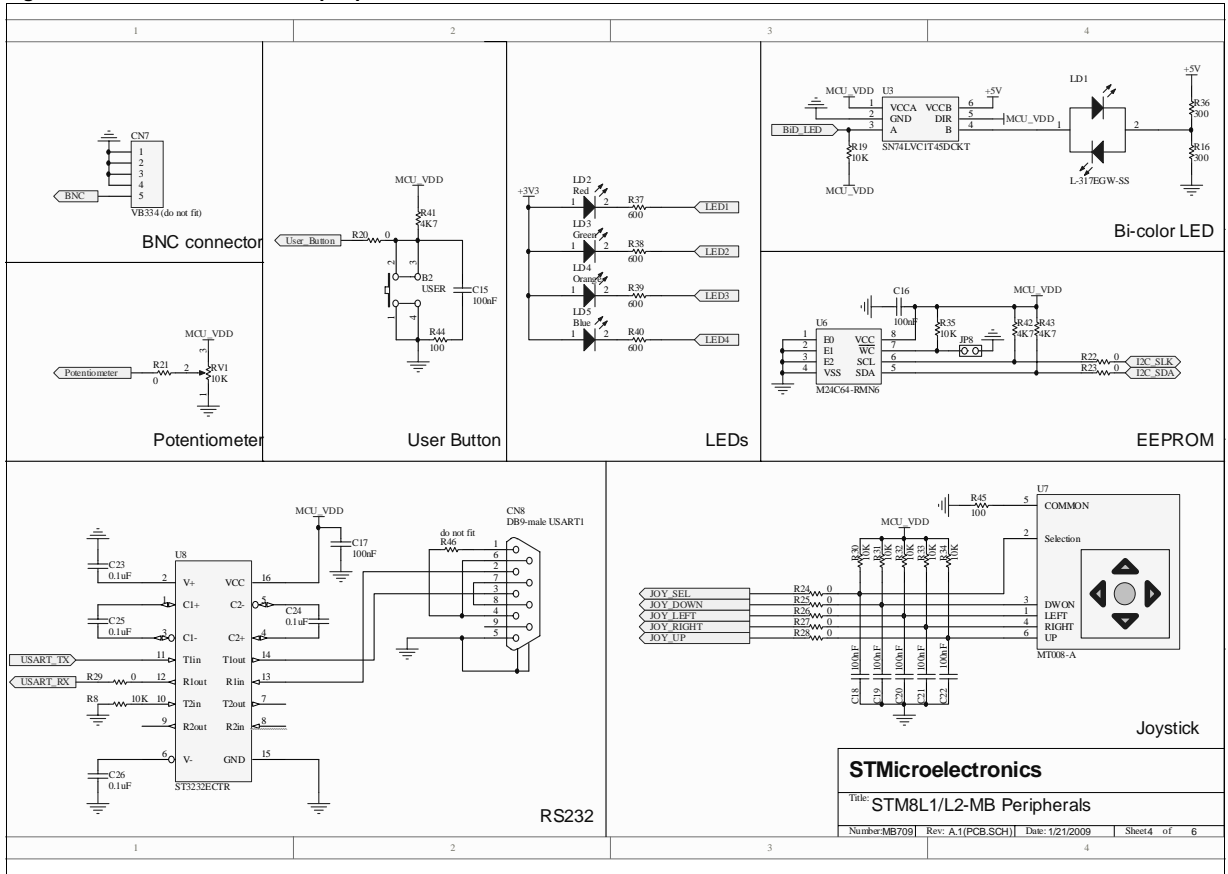

<b>STMicroelectronics</b>			
Title: STM8L1/L2-MB Peripherals			
Number: MB709	Rev: A.1 (PCB.SCH)	Date: 1/21/2009	Sheet 4 of 6



Figure 14. STM8L1/L2 motherboard audio

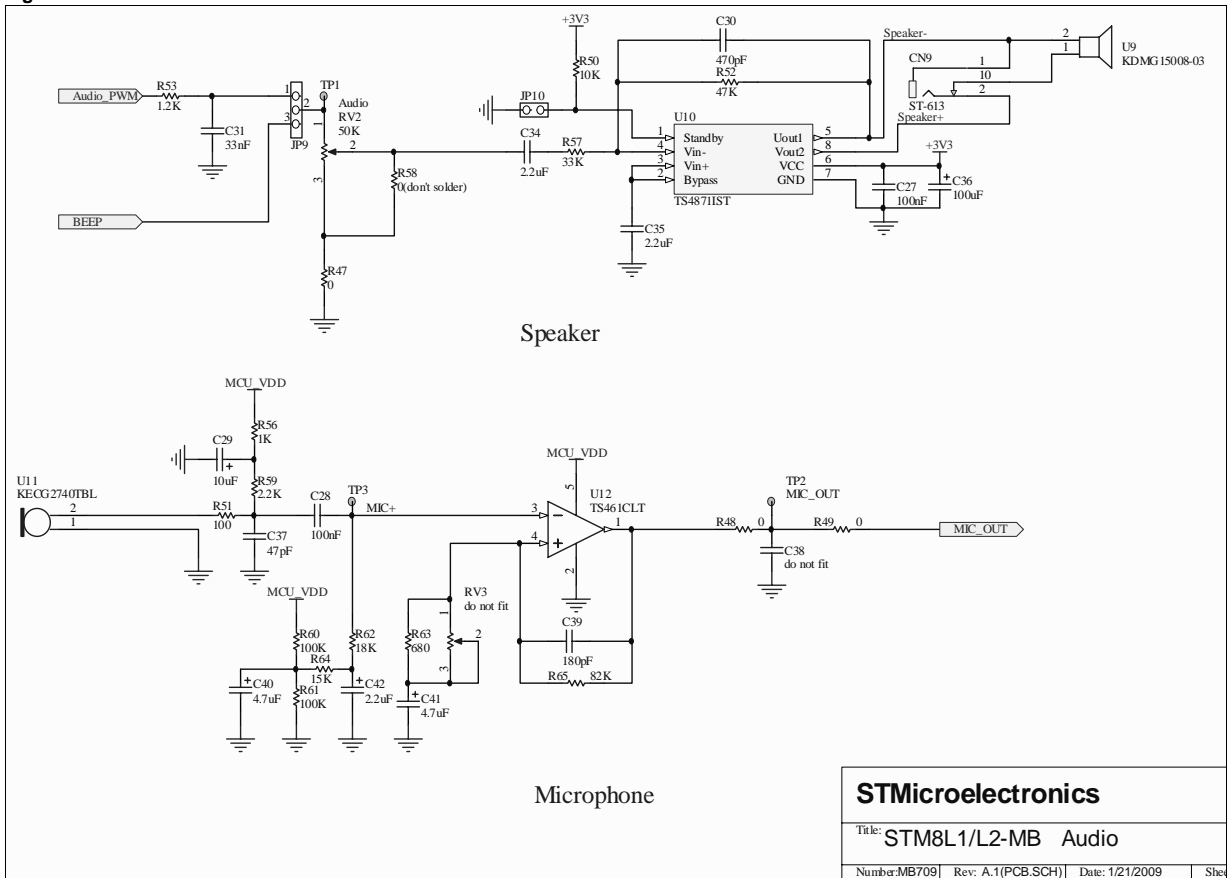

Doc ID 15312 Rev 2

21/26

UM0629

Schematics



Figure 15. STM8L1 motherboard power

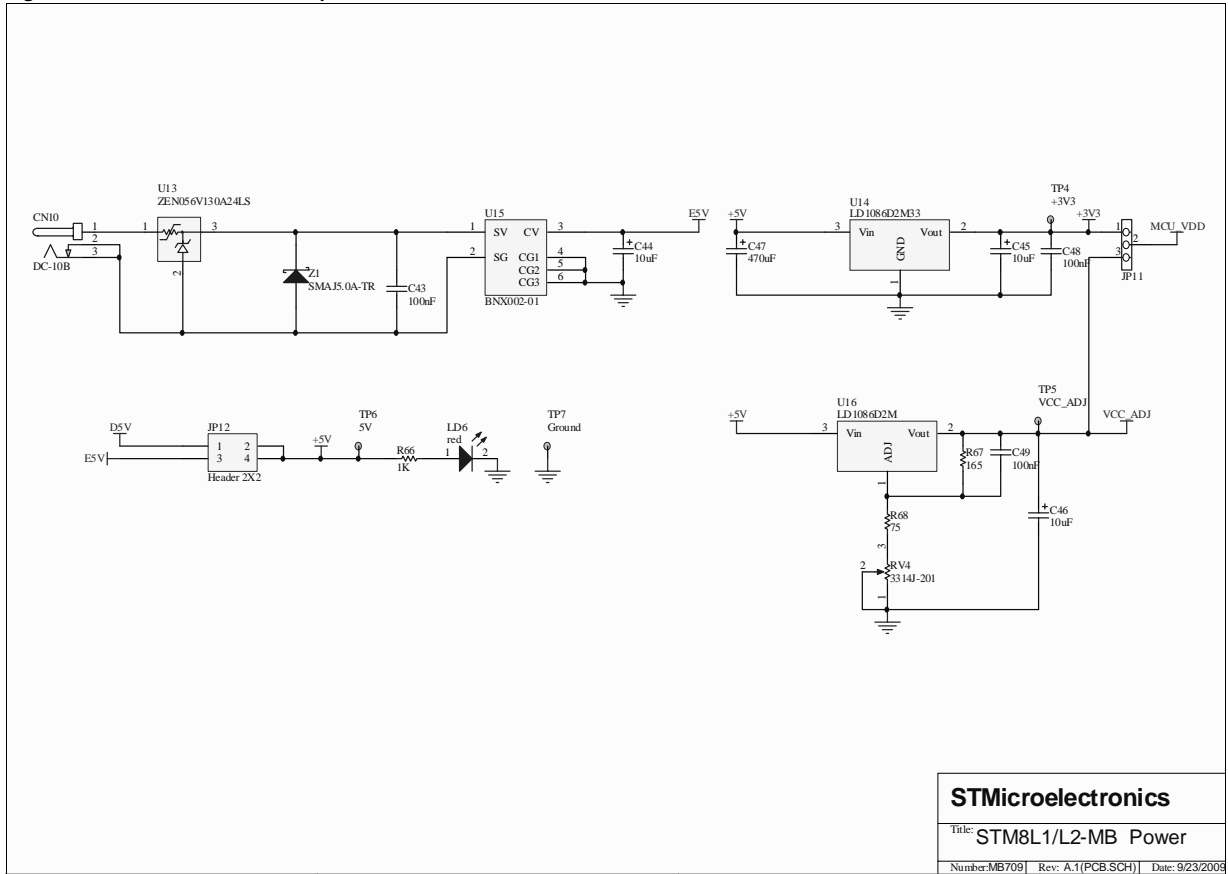



## 4.2 STM8L1-DB daughterboard schematic

Figure 16. Daughterboard schematic

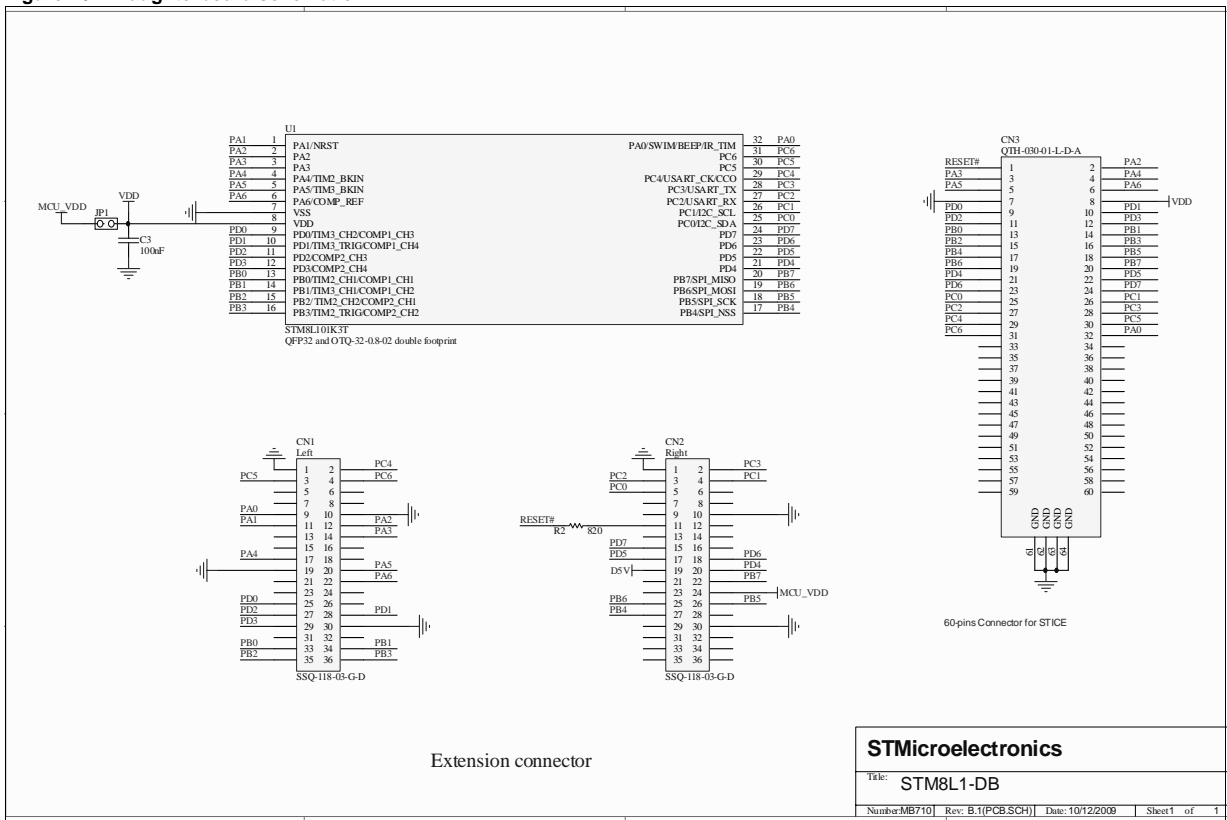

Doc ID 15312 Rev 2

23/26

UM0629

Schematics

## Appendix A STM8L101-EVAL I/O assignment

Table 13. STM8L101-EVAL input and output assignment

STM8L101 pin number	Pin name	STM8L101-EVAL pin assignment	STM8L101 pin number	Pin name	STM8L101-EVAL pin assignment
1	PA1 - NRESET	RESET	17	PB4	SD_card_CS
2	PA2	Unused	18	PB5	SPI_SCK
3	PA3	Unused	19	PB6	SPI_MOSI
4	PA4	Joystick down	20	PB7	SPI_MISO
5	PA5	User button	21	PD4	LED 1
6	PA6	COMP_REF	22	PD5	LED 2
7	VSS	GND	23	PD6	LED 3
8	VDD	VDD	24	PD7	Joystick select
9	PD0	Audio PWM_out	25	PC0	I <sup>2</sup> C_SDA_E2P
10	PD1	LCD_CS	26	PC1	I <sup>2</sup> C_SCL_E2P
11	PD2	CMP2_Potentiometer	27	PC2	USART_RX
12	PD3	CMP2_VREF	28	PC3	USART_TX
13	PB0	Bi-color LED	29	PC4	VREF_CTRL
14	PB1	Joystick left	30		
15	PB2	Joystick right	31		
16	PB3	Joystick up	32	PA0	SWIM / Beep



## 5 Revision history

Table 14. Document revision history

Date	Revision	Changes
29-Jan-2009	1	Initial release.
06-Nov-2009	2	Removed STIce and IrDA functionality. Modified , <a href="#">Section 2.5</a> , <a href="#">Section 2.6 Table 2</a> , <a href="#">Table 3</a> , <a href="#">Table 6</a> , <a href="#">Table 12</a> , <a href="#">Table 13</a> , <a href="#">Figure 2</a> , <a href="#">Figure 3</a> , <a href="#">Figure 4</a> all schematics and <a href="#">Appendix A</a> .

**Please Read Carefully:**

Information in this document is provided solely in connection with ST products. STMicroelectronics NV and its subsidiaries ("ST") reserve the right to make changes, corrections, modifications or improvements, to this document, and the products and services described herein at any time, without notice.

All ST products are sold pursuant to ST's terms and conditions of sale.

Purchasers are solely responsible for the choice, selection and use of the ST products and services described herein, and ST assumes no liability whatsoever relating to the choice, selection or use of the ST products and services described herein.

No license, express or implied, by estoppel or otherwise, to any intellectual property rights is granted under this document. If any part of this document refers to any third party products or services it shall not be deemed a license grant by ST for the use of such third party products or services, or any intellectual property contained therein or considered as a warranty covering the use in any manner whatsoever of such third party products or services or any intellectual property contained therein.

**UNLESS OTHERWISE SET FORTH IN ST'S TERMS AND CONDITIONS OF SALE ST DISCLAIMS ANY EXPRESS OR IMPLIED WARRANTY WITH RESPECT TO THE USE AND/OR SALE OF ST PRODUCTS INCLUDING WITHOUT LIMITATION IMPLIED WARRANTIES OF MERCHANTABILITY, FITNESS FOR A PARTICULAR PURPOSE (AND THEIR EQUIVALENTS UNDER THE LAWS OF ANY JURISDICTION), OR INFRINGEMENT OF ANY PATENT, COPYRIGHT OR OTHER INTELLECTUAL PROPERTY RIGHT.**

**UNLESS EXPRESSLY APPROVED IN WRITING BY AN AUTHORIZED ST REPRESENTATIVE, ST PRODUCTS ARE NOT RECOMMENDED, AUTHORIZED OR WARRANTED FOR USE IN MILITARY, AIR CRAFT, SPACE, LIFE SAVING, OR LIFE SUSTAINING APPLICATIONS, NOR IN PRODUCTS OR SYSTEMS WHERE FAILURE OR MALFUNCTION MAY RESULT IN PERSONAL INJURY, DEATH, OR SEVERE PROPERTY OR ENVIRONMENTAL DAMAGE. ST PRODUCTS WHICH ARE NOT SPECIFIED AS "AUTOMOTIVE GRADE" MAY ONLY BE USED IN AUTOMOTIVE APPLICATIONS AT USER'S OWN RISK.**

Resale of ST products with provisions different from the statements and/or technical features set forth in this document shall immediately void any warranty granted by ST for the ST product or service described herein and shall not create or extend in any manner whatsoever, any liability of ST.

ST and the ST logo are trademarks or registered trademarks of ST in various countries.

Information in this document supersedes and replaces all information previously supplied.

The ST logo is a registered trademark of STMicroelectronics. All other names are the property of their respective owners.

© 2009 STMicroelectronics - All rights reserved

STMicroelectronics group of companies

Australia - Belgium - Brazil - Canada - China - Czech Republic - Finland - France - Germany - Hong Kong - India - Israel - Italy - Japan - Malaysia - Malta - Morocco - Philippines - Singapore - Spain - Sweden - Switzerland - United Kingdom - United States of America

[www.st.com](http://www.st.com)