

PART NUMBER: VHB75

DESCRIPTION: dc-dc converter

features

- 37.5W-75W isolated output
- Efficiency to 85%
- 300KHz switching frequency
- 2:1 input range
- Regulated outputs
- Continuous short circuit protection
- Industry standard half-brick package
- Five-sided metal case
- Safety approvals

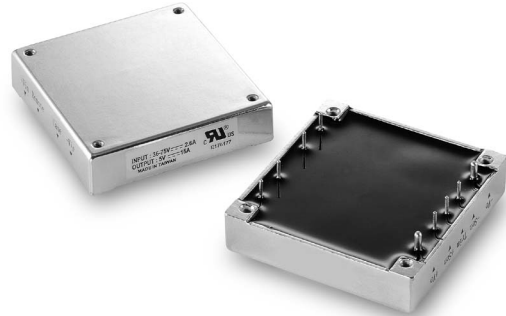

| MODEL | Input Voltage | Output Voltage | Output Current | Input Current | | Efficiency |
|----------------|---------------|----------------|----------------|---------------|-----------|------------|
| | | | | No Load | Full Load | |
| VHB75-D12-S2R5 | 9-18 VDC | 2.5VDC | 15A | 50mA | 4110mA | 76% |
| VHB75-D12-S3R3 | 9-18 VDC | 3.3VDC | 15A | 50mA | 5290mA | 78% |
| VHB75-D12-S5 | 9-18 VDC | 5VDC | 15A | 50mA | 7715mA | 81% |
| VHB75-D12-S12 | 9-18 VDC | 12VDC | 6.25A | 50mA | 7440mA | 84% |
| VHB75-D12-S15 | 9-18 VDC | 15VDC | 5A | 50mA | 7440mA | 84% |
| VHB75-D12-S24 | 9-18 VDC | 24VDC | 3.13A | 50mA | 7440mA | 84% |
| VHB75-D24-S2R5 | 18-36 VDC | 2.5VDC | 15A | 50mA | 2029mA | 77% |
| VHB75-D24-S3R3 | 18-36 VDC | 3.3VDC | 15A | 50mA | 2610mA | 79% |
| VHB75-D24-S5 | 18-36 VDC | 5VDC | 15A | 50mA | 3810mA | 82% |
| VHB75-D24-S12 | 18-36 VDC | 12VDC | 6.25A | 50mA | 3675mA | 85% |
| VHB75-D24-S15 | 18-36 VDC | 15VDC | 5A | 50mA | 3675mA | 85% |
| VHB75-D24-S24 | 18-36 VDC | 24VDC | 3.13A | 50mA | 3640mA | 86% |
| VHB75-D48-S2R5 | 36-75 VDC | 2.5VDC | 15A | 50mA | 1015mA | 77% |
| VHB75-D48-S3R3 | 36-75 VDC | 3.3VDC | 15A | 50mA | 1305mA | 79% |
| VHB75-D48-S5 | 36-75 VDC | 5VDC | 15A | 50mA | 1883mA | 83% |
| VHB75-D48-S12 | 36-75 VDC | 12VDC | 6.25A | 50mA | 1838mA | 85% |
| VHB75-D48-S15 | 36-75 VDC | 15VDC | 5A | 50mA | 1838mA | 86% |
| VHB75-D48-S24 | 36-75 VDC | 24VDC | 3.13A | 50mA | 1820mA | 86% |



PART NUMBER: VHB75

DESCRIPTION: dc-dc converter

INPUT

| | | |
|-----------------------|---------|------------------------------------|
| Input Voltage Range | 12V: | 9-18V |
| | 24V: | 18-36V |
| | 48V: | 36-75V |
| Under Voltage Lockout | 12 Vin: | power up 8.8V power down 8V |
| | 24Vin: | power up 17V power down 16V |
| | 48Vin: | power down 34V power down 32.5V |
| ON/OFF Control | | see notes 3&4 |
| Input Filter | | PI Type |

OUTPUT

| | | |
|---|----------------|------------------------------|
| Voltage Accuracy | | ±1% max. |
| Transient Response: 25% Step Load Change | | <500µ sec. |
| External Trim Adj. Range | | ±10% |
| Ripple & Noise | 2.5V, 3.3V, 5V | 20 mV RMS., max |
| 20MHz BW | 12V & 15V | 75 mV p-p., max |
| | | 30 mV RMS., max |
| | 24V | 100 mV p-p., max |
| | | 100 mV RMS., max |
| | | 240 mV p-p, max |
| Temperature Coefficient | | ±0.03%/°C |
| Short Circuit Protection | Continuous | |
| Safety | | approved to UL1950 (E222736) |
| Line Regulation ¹ | | ±0.2% max |
| Load Regulation ² | | ±0.2% max |
| Over Voltage Protection trip Range, % Vo nom. | | 115-140% |
| Current Limit | | 110-150% Nominal Output |

GENERAL SPECIFICATIONS

| | | |
|------------------------------|--------------|---|
| Efficiency | | see table |
| Isolation Voltage | Input/Output | 1500VDC min. |
| | Input/Case | 1500VDC min. |
| | Output/Case | 1500VDC min. |
| Isolation Resistance | | 10 ⁷ Ohm min. |
| Switching Frequency | 12-24Vin | 400kHz, Typ. |
| | 48Vin | 300kHz, Typ |
| Operating Case Temperature | | -40°C ~ +100°C |
| Storage Temperature | | -55°C ~ +105°C |
| Thermal Shutdown, Case Temp. | | 100°C Typ. |
| Dimensions | | 2.28x2.40x0.50 inches (57.9x61.0x12.7mm) |
| Case Material | | aluminum |

NOTES:

1. Measured from high line to low line
2. Measured from full load to zero load
3. On/Off Control: Positive logic default. Referenced to -Vin. Open collector.
Module ON...open circuit
Module OFF...<0.8Vdc
4. For negative logic On/Off control, add suffix "N" to the model number

PART NUMBER: VHB75

DESCRIPTION: dc-dc converter

APPLICATION NOTES

1. OUTPUT DE-RATING

The operating case temperature range of the VHB75 series is -40°C to +100°C. When operating the VHB75, proper derating or cooling is needed. Following is the derating curve of VHB75 without heat sink.

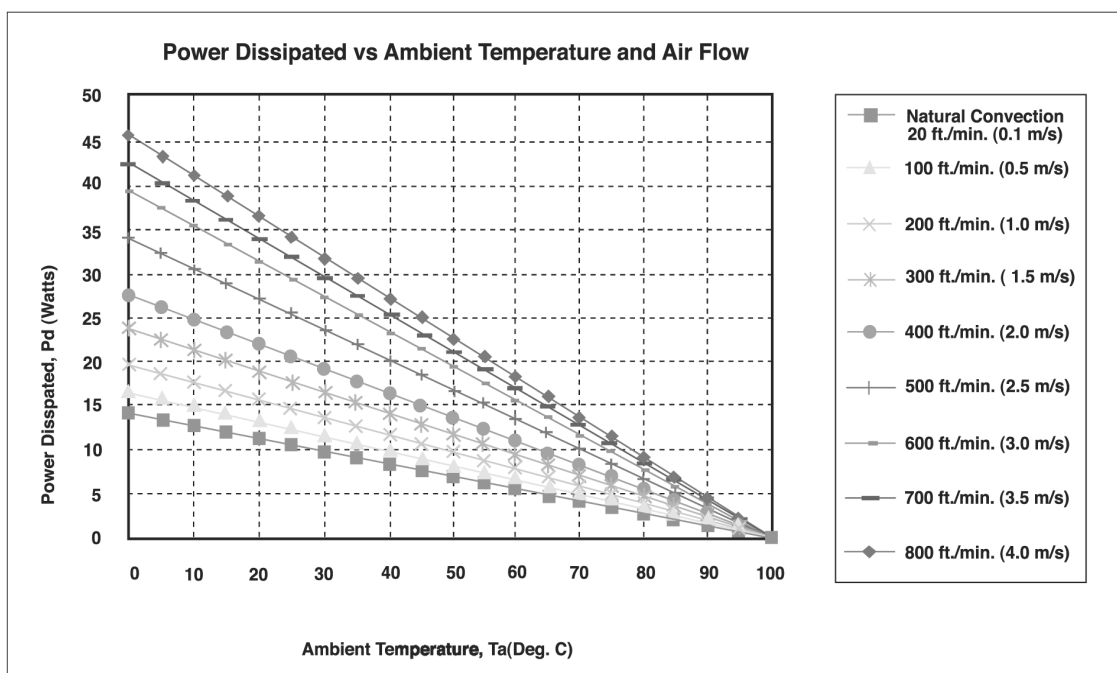

FIGURE 1. OUTPUT DERATING (FORCED CONVECTION WITH NO HEAT SINK)

Where:

The power dissipation (P_d) is

$$P_d = P_i - P_o = P_o (1 - \eta) / \eta$$

The thermal resistances are listed below.

Chart of Thermal Resistance vs Air Flow:

| AIR FLOW RATE | TYPICAL R_{ca} |
|--|------------------|
| Natural Convection 20ft./min. (0.1m/s) | 7.12 °C/W |
| 100 ft./min. (0.5m/s) | 6.21 °C/W |
| 200 ft./min. (1.0m/s) | 5.17 °C/W |
| 300 ft./min. (1.5m/s) | 4.29 °C/W |
| 400 ft./min. (2.0m/s) | 3.64 °C/W |
| 500 ft./min. (2.5m/s) | 2.96 °C/W |
| 600 ft./min. (3.0m/s) | 2.53 °C/W |
| 700 ft./min. (3.5m/s) | 2.37 °C/W |
| 800 ft./min. (4.0m/s) | 2.19 °C/W |

The temperature rise (ΔT):

$$\Delta T = P_d * R_{ca}$$

PART NUMBER: VHB75

DESCRIPTION: dc-dc converter

2. OUTPUT TRIMMING (OPTIONAL)

The output voltages are preset to nominal values as indicated by the models table at the factory. If desired, the output voltage may optionally be trimmed to a different value (+/- 10%) with external resistors and/or potentiometer as shown below.

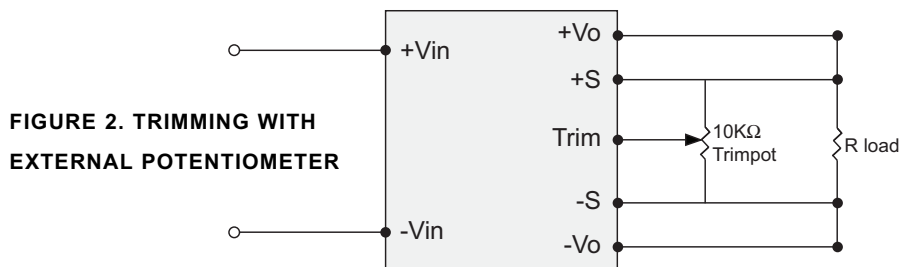
FIGURE 2. TRIMMING WITH EXTERNAL POTENTIOMETER

To trim the output voltage with fixed resistors, the output voltage can be calculated as follows.

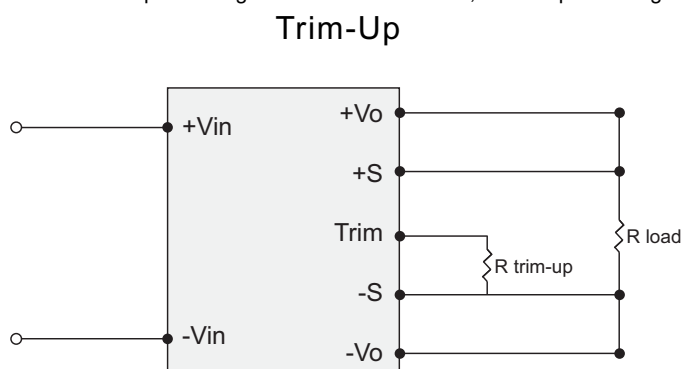
FIGURE 3: TRIM-UP VOLTAGE SETUP

The value of $R_{trim-up}$ is defined as:

$$R_{trim-up} = \frac{R1 - R2 \times (V_o - V_{o, nom})}{V_o - V_{o, nom}} \text{ (K}\Omega\text{)}$$

Where: $R_{trim-up}$ is the external resistor in $K\Omega$. $V_{o, nom}$ is the nominal output voltage. V_o is the desired output voltage.

R_1 and R_2 are internal to the unit and are defined in Table 1. For example, to trim-up the output voltage of 5.0V module (VHB75-Q48-S5) by 8% to 5.4V, $R_{trim-up}$ is calculated as follows:

$$V_o - V_{o, nom} = 5.4 - 5.0 = 0.4 \text{ V}$$

$$R1 = 5.8 \text{ K}\Omega$$

$$R2 = 8.25 \text{ K}\Omega$$

$$R_{trim-up} = \frac{5.8 - 8.25 \times 0.4}{0.4} = 6.25 \text{ (K}\Omega\text{)}$$

Table 1

| Output Voltage(V) | R1(KΩ) | R2(KΩ) |
|-------------------|--------|--------|
| 2.5V | 2.877 | 8.25 |
| 3.3V | 3.168 | 7.2 |
| 5V | 5.8 | 8.25 |
| 12V | 19.656 | 13.304 |
| 15V | 25.474 | 14.76 |
| 24V | 42.215 | 16.923 |

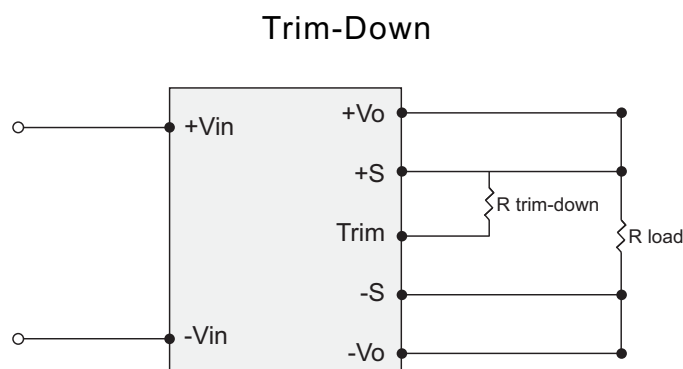
FIGURE 4: TRIM-DOWN VOLTAGE SETUP

The value of $R_{trim-down}$ is defined as:

$$R_{trim-down} = \frac{R1 - R2 \times (V_o, nom - V_o)}{V_o, nom - V_o} \text{ (K}\Omega\text{)}$$

Where: $R_{trim-down}$ is the external resistor in $K\Omega$. $V_{o, nom}$ is the nominal output voltage. V_o is the desired output voltage.

R_1 and R_2 are internal to the unit and are defined in Table 2. For example, to trim-down the output voltage of 5.0V module (VHB75-Q48-S5) by 8% to 4.6V, $R_{trim-down}$ is calculated as follows:

$$V_{o, nom} - V_o = 5.0 - 4.6 = 0.4 \text{ V}$$

$$R1 = 5.8 \text{ K}\Omega$$

$$R2 = 10.57 \text{ K}\Omega$$

$$R_{trim-down} = \frac{5.8 - 10.57 \times 0.4}{0.4} = 3.93 \text{ (K}\Omega\text{)}$$

Table 2

| Output Voltage(V) | R1(KΩ) | R2(KΩ) |
|-------------------|--------|--------|
| 2.5V | 2.923 | 10.57 |
| 3.3V | 6.18 | 15 |
| 5V | 5.8 | 10.57 |
| 12V | 86.45 | 60.1 |
| 15V | 150 | 94 |
| 24V | 430 | 130 |

PART NUMBER: VHB75

DESCRIPTION: dc-dc converter

Remote On/Off Control

The VHB75 series allows the user to switch the module on and off electronically with the remote on/off feature. Logic control defaults to "positive" logic. The diagram shows the recommended circuits for positive logic. The "negative logic" option is also available.

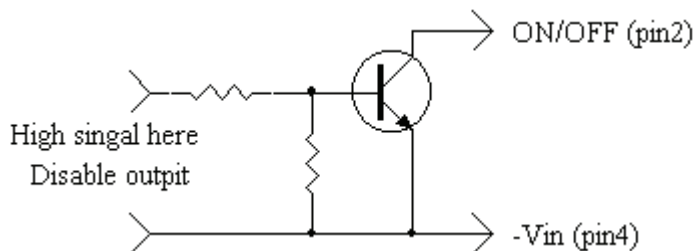

Logic table

| Logic State(pin2) | Negative logic | Positive logic |
|-------------------------|----------------|----------------|
| Logic Low-Switch Closed | Module on | Module off |
| Logic High-Switch Open | Module off | Module on |

External Output Trimming

Output may optionally be trimmed ($\pm 10\%$) with external fixed resistors or an external trimpot as shown.

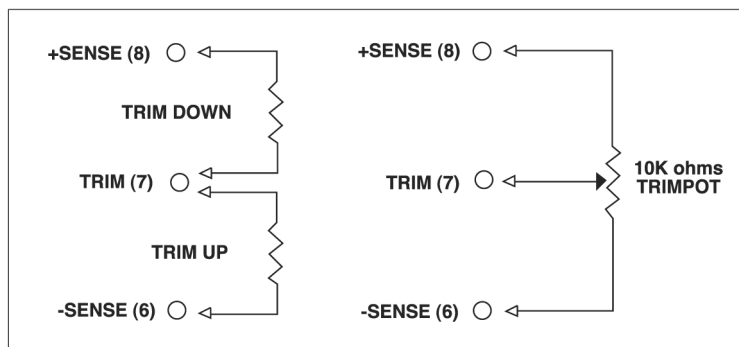

Output Noise

The output noise is measured with a 10uF tantalum capacitor and a 1.0uF ceramic capacitor across the output.

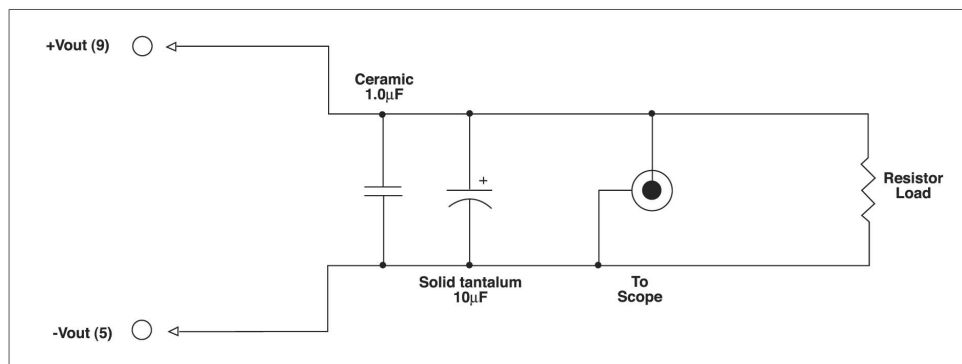

Output Noise Test Circuit schematic

PART NUMBER: VHB75

DESCRIPTION: dc-dc converter

All Dimensions In Inches(mm)

| Tolerances | Inches | .XX±.02 | .XXX±.010 | Pin ±0.02 |
|------------|-------------|---------|-----------|--------------|
| | Millimeters | .X±.5 | .XX±.25 | ±0.5 |

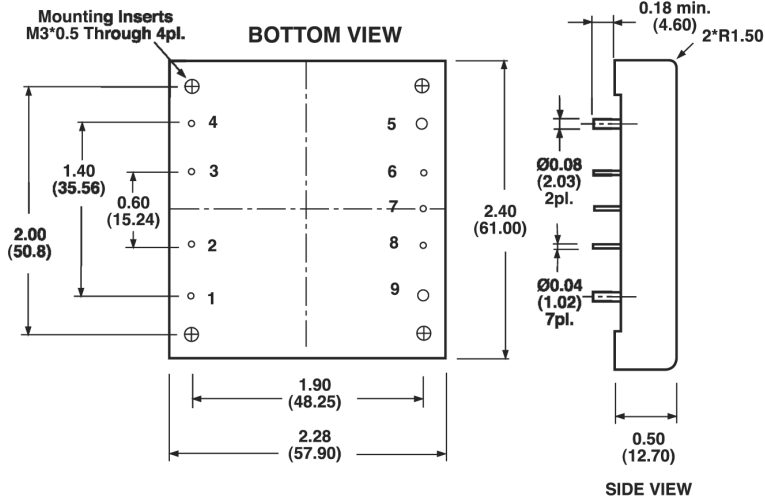

PIN CONNECTION

| Pin | Function |
|-----|----------|
| 1. | +Vin |
| 2. | ON/OFF |
| 3. | CASE |
| 4. | -Vin |
| 5. | -Vout |
| 6. | -Sense |
| 7. | Trim |
| 8. | +Sense |
| 9. | +Vout |