

PART NUMBER: VHB50W

DESCRIPTION: half-brick dc-dc converter

description

The VHB50W series of DC-DC converters are designed for high reliability applications, featuring over-temperature protection, over-current protection. The wide 4:1 input range (9-36V or 18-75V) is very useful to stabilize an input source like batteries in various discharging and charging conditions. Additionally, high efficiency, fast response, tight regulations, remote sense and remote On/Off control make these converters very useful in many applications.

features

- 25-50W isolated output
- Efficiency to 84%
- 300 kHz switching frequency
- regulated output
- continuous short circuit protection
- industry standard half-brick size
- remote on/off
- over-temperature protection
- over-current protection

MODEL

MODEL	input voltage		output voltage (V dc)	output current ¹ (A)	input current		efficiency typ. ³ (%)
	nominal (V dc)	range (V dc)			no load ² (mA)	full load ² (mA)	
VHB50W-Q24-S3R3	24	9.0~36.0	3.3	10	50	1785	77
VHB50W-Q24-S5	24	9.0~36.0	5	10	50	2637	81
VHB50W-Q24-S12	24	9.0~36.0	12	4.16	50	2537	83
VHB50W-Q24-S15	24	9.0~36.0	15	3.33	50	2538	83
VHB50W-Q24-S24	24	9.0~36.0	24	2.08	50	2537	83
VHB50W-Q24-S28	24	9.0~36.0	28	1.78	50	2537	83
VHB50W-Q24-S48	24	9.0~36.0	48	1.04	50	2537	83
VHB50W-Q48-S3R3	48	18.0~75.0	3.3	10	50	905	78
VHB50W-Q48-S5	48	18.0~75.0	5	10	50	1302	82
VHB50W-Q48-S12	48	18.0~75.0	12	4.16	50	1267	84
VHB50W-Q48-S15	48	18.0~75.0	15	3.33	50	1265	84
VHB50W-Q48-S24	48	18.0~75.0	24	2.08	50	1264	84
VHB50W-Q48-S28	48	18.0~75.0	28	1.78	50	1264	84
VHB50W-Q48-S48	48	18.0~75.0	48	1.04	50	1253	83

- notes:
1. see output derating (page 4)
 2. input currents are measured at nominal input voltage
 3. efficiency is measured at nominal line, full load

INPUT

parameter	conditions/description	min	nom	max	units
input voltage range		9	24	36	V dc
		18	48	75	V dc
under voltage lockout	24 Vin power up		8.8		V dc
	24 Vin power down		8		V dc
	48 Vin power up		17		V dc
	48 Vin power down		16		V dc
remote on/off control ⁴	section 15 in the application notes				
input filter	PI type				

- notes:
4. add suffix "N" to the model number for negative logic on/off control

*V-Infinity reserves the right to make changes to its products or to discontinue any product or service without notice, and to advise customers to verify the most up-to-date product information before placing orders. V-Infinity assumes no liability or responsibility for customer's applications using V-Infinity products other than repair or replacing (at V-I's option) V-Infinity products not meeting V-I's published specifications. Nothing will be covered outside of standard product warranty.

PART NUMBER: VHB50W

DESCRIPTION: half-brick dc-dc converter

OUTPUT

parameter	conditions/description	min	nom	max	units
voltage accuracy				±1	%
transient response	25% step load change			<500	µ sec
external trim adj. range				±10	%
ripple & noise (20MHz BW)	3.3V, 5V			40	mV RMS
				100	mV p-p
	12V& 15V			60	mV RMS
				150	mV p-p
	24V			100	mV RMS
				240	mV p-p
	28V			100	mV RMS
			280	mV p-p	
48V			200	mV RMS	
			480	mV p-p	
temperature coefficient			±0.03	%/°C	
short circuit protection	continuous				
line regulation ⁵				±0.2	%
load regulation ⁶				±0.2	%
over voltage protection trip range, % Vo nom.		115		140	%
over current protection	% nominal output current	110		160	%

GENERAL SPECIFICATIONS

parameter	conditions/description	min	nom	max	units
switching frequency			300		KHz
operating ambient temp. ⁷		-40		100	°C
storage temperature		-55		105	°C
thermal shutdown case temp.			100		°C
case material	aluminum				

ISOLATION SPECIFICATIONS

parameter	conditions/description	min	nom	max	units
isolation voltage	input/output	1500			V dc
	input/case	1500			V dc
	output/case	1500			V dc
isolation resistance		100			MΩ

notes:
 5. measured from high line to low line at full load
 6. measured from full load to zero load at nominal input
 7. see output derating curve (page 4)

*V-Infinity reserves the right to make changes to its products or to discontinue any product or service without notice, and to advise customers to verify the most up-to-date product information before placing orders. V-Infinity assumes no liability or responsibility for customer's applications using V-Infinity products other than repair or replacing (at V-I's option) V-Infinity products not meeting V-I's published specifications. Nothing will be covered outside of standard product warranty.



PART NUMBER: VHB50W

DESCRIPTION: half-brick dc-dc converter

MECHANICAL DRAWING

All Dimensions In Inches(mm)

Tolerances	Inches	.XX±.02	.XXX±.010	Pin ±0.02
	Millimeters	.X±.5	.XX±.25	±0.5

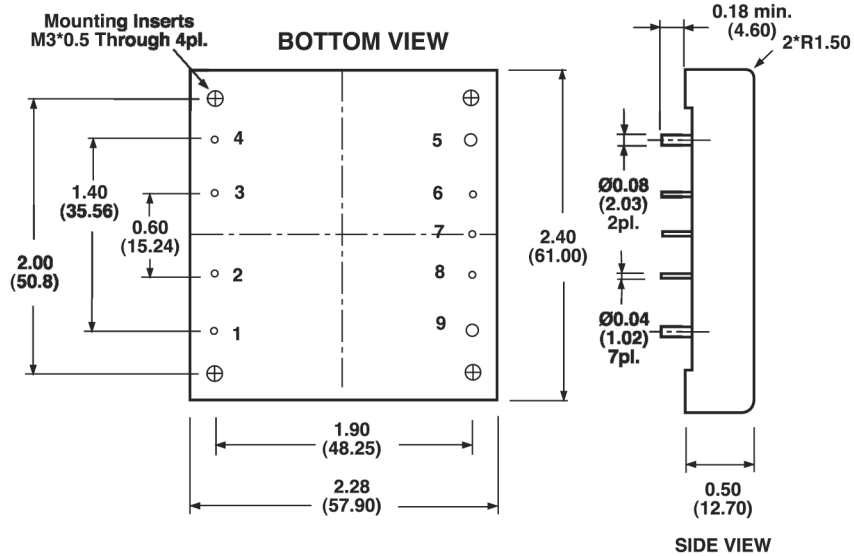

PIN CONNECTION

Pin	Function
1.	+Vin
2.	ON/OFF
3.	CASE
4.	-Vin
5.	-Vout
6.	-Sense
7.	Trim
8.	+Sense
9.	+Vout

PART NUMBER: VHB50W

DESCRIPTION: half-brick dc-dc converter

APPLICATION NOTES

1. OUTPUT DE-RATING

The operating case temperature range for VHB50W is -40 ~ +100°C. When operating the VHB50W series, proper derating or cooling is needed. The maximum case temperature under any operating condition should not exceed 100°C.

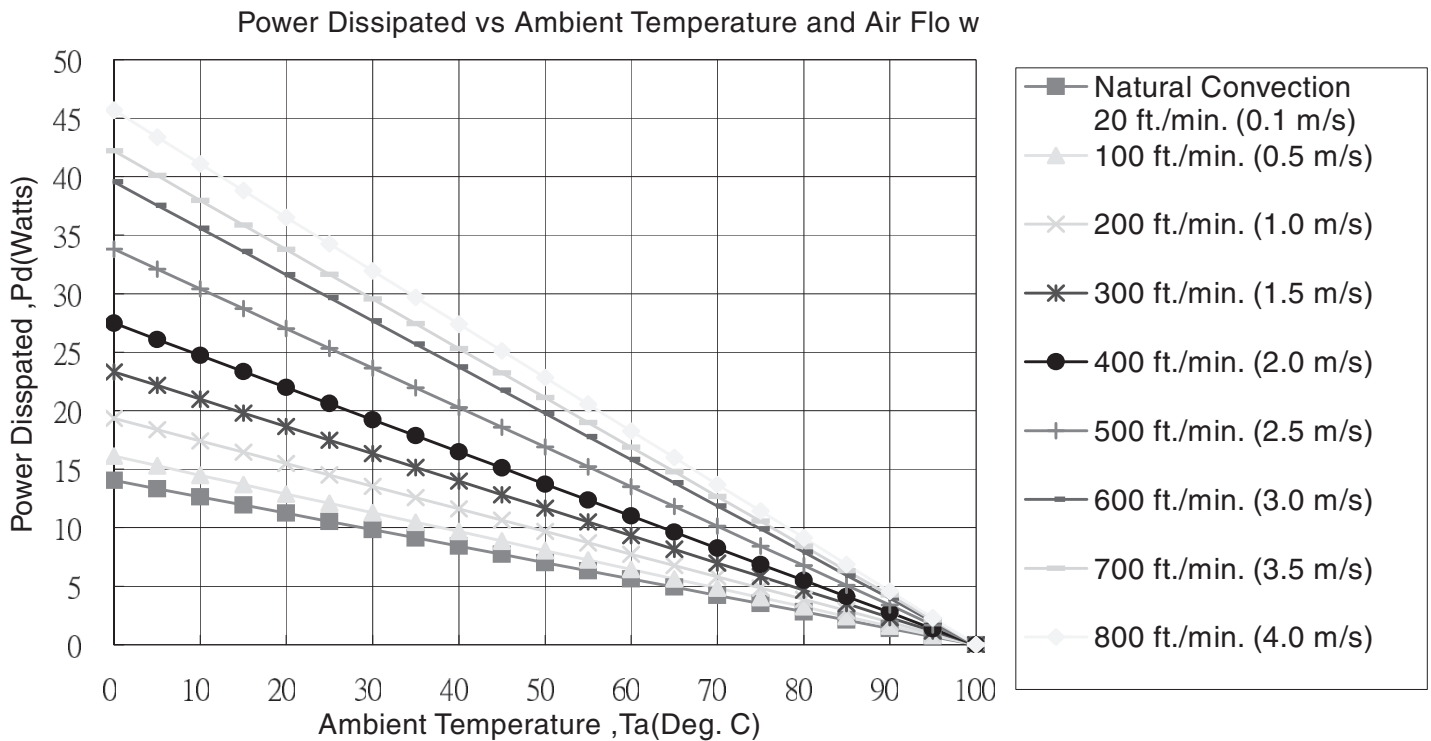

FIGURE 1. OUTPUT DERATING (FORCED CONVECTION WITH NO HEAT SINK)

Example:

What is the minimum airflow necessary for a VHB50W-Q48-S12 operating at nominal line, an output current of 4.16 A, and a maximum ambient temperature of 60°C?

Solution:

Given: $V_{in}=48$ V dc, $V_o=12$ V dc, $I_o=4.16$ A

Determine Power dissipation (Pd):

$$P_d = P_i - P_o = P_o(1 - \eta) / \eta$$

$$P_d = 12 \times 4.16 \times (1 - 0.84) / 0.84 = 9.51 \text{ W}$$

Determine airflow:

Given: $P_d=9.51$ W and $T_a=60^\circ\text{C}$

Check above Power de-rating curve:

minimum airflow= 400 ft./min.

Verifying:

The maximum temp. rise $\Delta T = P_d \times R_{ca} = 9.51 \times 3.64 = 34.6^\circ\text{C}$. The maximum case temperature $T_c = T_a + \Delta T = 94.6^\circ\text{C} < 100^\circ\text{C}$

Where:

The R_{ca} is thermal resistance from case to ambience. The T_a is ambient temperature and the T_c is case temperature.

AIR FLOW RATE	TYPICAL R_{ca}
Natural Convection	7.12 °C/W
20ft./min. (0.1m/s)	7.12 °C/W
100 ft./min. (0.5m/s)	6.21 °C/W
200 ft./min. (1.0m/s)	5.17 °C/W
300 ft./min. (1.5m/s)	4.29 °C/W
400 ft./min. (2.0m/s)	3.64 °C/W
500 ft./min. (2.5m/s)	2.96 °C/W
600 ft./min. (3.0m/s)	2.53 °C/W
700 ft./min. (3.5m/s)	2.37 °C/W
800 ft./min. (4.0m/s)	2.19 °C/W

Chart of Thermal Resistance vs Air Flow

PART NUMBER: VHB50W

DESCRIPTION: half-brick dc-dc converter

2. INPUT VOLTAGE RANGE

It is important to ensure the input voltage measured at the converter input pins is within the range for that converter. Make sure wire losses and voltage ripples are accounted for. One possible problem is driving the converter with a linear unregulated power supply. For example, if the average voltage measured by a DMM is 9V, with a voltage ripple of 3Vpp, the actual input can swing from 7.5V to 10.5V. This will be outside the specified input range of 9-36V and the converter may not function properly. On the other end, make sure the actual input voltage does not exceed the highest voltage of 36V or 75V.

3. LEAD WIRES

Make sure the input and output wires are of adequate AWG size to minimize voltage drop, and ensure the voltage across the input terminals is above the converter's rated minimum voltage at all times. It is recommended to have the wire pairs twisted, respectively for the input pair and the output pair, so as to minimize noise pickup.

4. INPUT CURRENT

The input voltage source must be able to provide enough current to the converter, otherwise it may not start up or operate properly. A typical symptom is not starting or unusually low output voltage. In general, it is recommended to be able to provide at least:

$I_{peak} = 150\% * P_{out} / (\eta * V_{min})$ where P_{out} is the maximum output power, V_{min} is the minimum input voltage and η is the converter's efficiency. As an example, for VHB50W-Q24-S5 to operate with 9~36 V input, 50 W output and an efficiency of 81%, the minimum source current is recommended to be: **$I_{peak} = 150\% * 50 / (81\% * 9) = 10.29 \text{ A}$** .

5. INPUT FUSE

To limit the input current and to facilitate input reversal protection and input OVP protection, a fast-acting input fuse is recommended for the input line. The fuse rating will depend on the input range and should allow for the maximum current at the lowest input voltage, as shown in this equation: **$I_{peak} = 150\% * P_{out} / (\eta * V_{min})$** .

In the previous example of VHB50W-Q24-S5, the peak input current at 9V was calculated to be 10.29 A. A 15 A fuse may be suitable for this application. Make sure the fuse voltage rating is higher than the maximum input voltage.

6. REMOTE SENSE

The converter provides regulated outputs at the output terminals. When there is a large current and/or the output cable is of some length, the voltage at the end of the output cable may be noticeably lower than at the terminals. The converter can compensate up to 0.5V of voltage drop through remote sense terminals. To ensure accurate regulation, run two separate wires (twisted) from the desired regulation points to the remote sense terminals, as shown below.

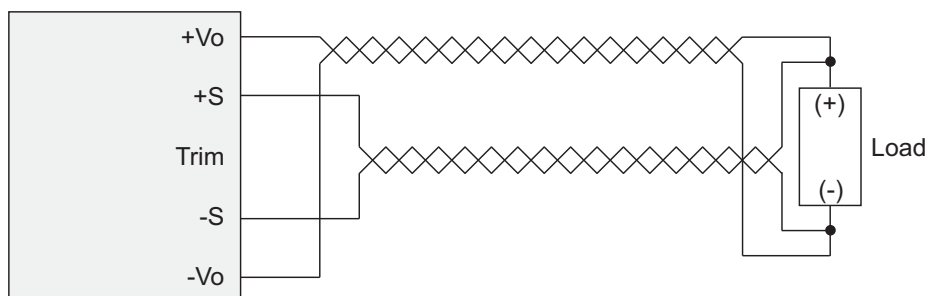
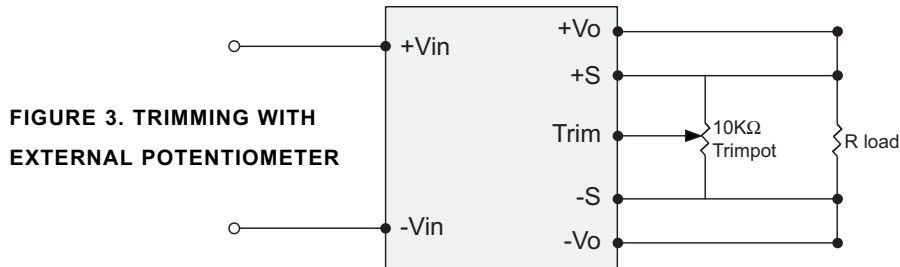

FIGURE 2. REMOTE SENSE

PART NUMBER: VHB50W

DESCRIPTION: half-brick dc-dc converter

7. OUTPUT TRIMMING (OPTIONAL)

The output voltages are preset to nominal values as indicated by the models table at the factory. If desired, the output voltage may optionally be trimmed to a different value (+/- 10%) with external resistors and/or potentiometer as shown below.

FIGURE 3. TRIMMING WITH EXTERNAL POTENTIOMETER

To trim the output voltage with fixed resistors, the output voltage can be calculated as follows.

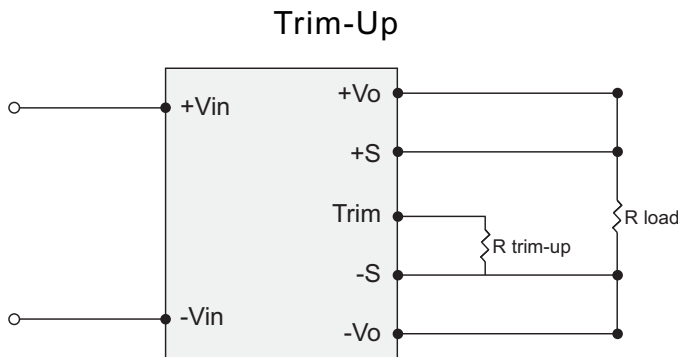
FIGURE 4: TRIM-UP VOLTAGE SETUP

The value of $R_{trim-up}$ is defined as:

$$R_{trim-up} = \frac{R1 - R2 \times (V_o - V_{o, nom})}{V_o - V_{o, nom}} \text{ (K}\Omega\text{)}$$

Where: $R_{trim-up}$ is the external resistor in $K\Omega$. $V_{o, nom}$ is the nominal output voltage. V_o is the desired output voltage.

R_1 and R_2 are internal to the unit and are defined in Table 1. For example, to trim-up the output voltage of 5.0V module (VHB50W-Q48-S5) by 8% to 5.4V, $R_{trim-up}$ is calculated

as follows:

$$V_o - V_{o, nom} = 5.4 - 5.0 = 0.4 \text{ V}$$

$$R1 = 5.8 \text{ K}\Omega$$

$$R2 = 3.3 \text{ K}\Omega$$

$$R_{trim-up} = \frac{5.8 - 3.3 \times 0.4}{0.4} = 11.2 \text{ (K}\Omega\text{)}$$

Table 1

Output Voltage(V)	R1(KΩ)	R2(KΩ)
3.3V	3.168	7.2
5V	5.8	3.3
12V	18.945	4.636
15V	25.189	7.191
24V	25.189	6.977
28V	608.6	173.7
48V	74.25	13.3

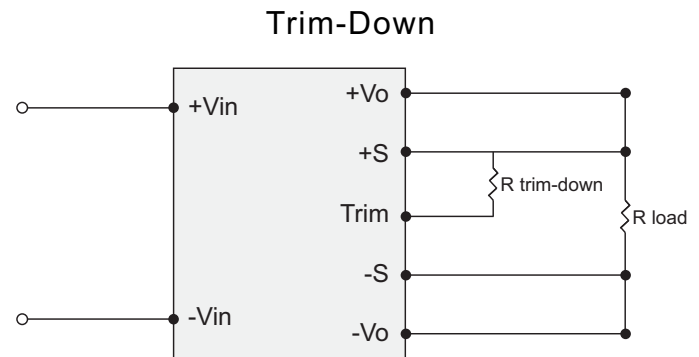
FIGURE 5: TRIM-DOWN VOLTAGE SETUP

The value of $R_{trim-down}$ is defined as:

$$R_{trim-down} = \frac{R1 - R2 \times (V_{o, nom} - V_o)}{V_{o, nom} - V_o} \text{ (K}\Omega\text{)}$$

Where: $R_{trim-down}$ is the external resistor in $K\Omega$. $V_{o, nom}$ is the nominal output voltage. V_o is the desired output voltage.

R_1 and R_2 are internal to the unit and are defined in Table 2. For example, to trim-down the output voltage of 5.0V module (VHB50W-Q48-S5) by 8% to 4.6V, $R_{trim-down}$ is calculated

as follows:

$$V_{o, nom} - V_o = 5.0 - 4.6 = 0.4 \text{ V}$$

$$R1 = 5.8 \text{ K}\Omega$$

$$R2 = 5.32 \text{ K}\Omega$$

$$R_{trim-down} = \frac{5.8 - 5.32 \times 0.4}{0.4} = 9.18 \text{ (K}\Omega\text{)}$$

Table 2

Output Voltage(V)	R1(KΩ)	R2(KΩ)
3.3V	6.18	15
5V	5.8	5.32
12V	86.45	60.1
15V	150	68
24V	430	120
28V	608.6	173.7
48V	1638	306

PART NUMBER: VHB50W

DESCRIPTION: half-brick dc-dc converter

8. OUTPUT OCP AND SHORT-CIRCUIT PROTECTION

Output overload and short circuit conditional will cause the output voltage to decline or shutdown altogether. If the case temperature is not over 100°C, the output recovers automatically when the short or OCP conditions are removed. In the case of slight overloading, the output voltage may not shut down, but the converter may build up heat over time, causing over-temperature shutdown.

9. OVER-TEMPERATURE PROTECTION

When the case temperature reaches about 100°C, the converter's built-in protection circuit will shut down the output. When the temperature is reduced enough to a safe operating level, the converter will recover to normal operations automatically.

10. OUTPUT OVP

In case the output voltage exceeds the OVP threshold, the converter shuts down.

11. OUTPUT PARALLEL CONNECTIONS

The converter is not designed for load share on the output. One may be inclined to use this circuit to force current sharing by trimming the output voltages for each converter. However, this circuit may not reliably or accurately divide the load current, as the device characteristics of the converters or the diodes may not be balanced over a range of operating conditions. We generally do not recommend this circuit to increase power output over a single converter. Instead, we recommend this setup for redundancy only, having one converter as a backup in case of a failure. Make sure the OR-ing diodes can handle the voltage and full load current.

**FIGURE 6. OUTPUT
PARALLEL CONNECTIONS**

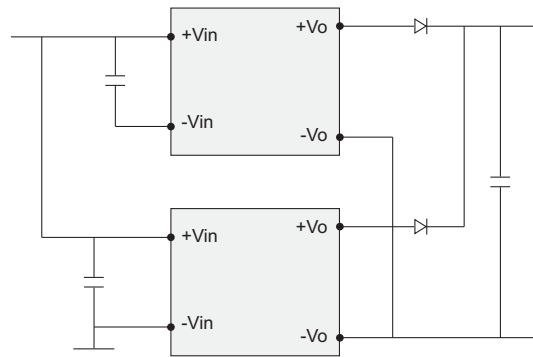

PART NUMBER: VHB50W

DESCRIPTION: half-brick dc-dc converter

12. OUTPUT SERIES CONNECTIONS

Two or more converters can be connected in series to obtain a higher output voltage. To prevent output reverse biasing each other in case of a short, add a Schottky diode on each output in reverse polarity, as shown in the diagram. In the event of a short, the converters will forward-bias the diodes and the output reversal will be limited to one diode drop (about 0.5V) only, so as not to damage the converters. The forward current will cause each converter to go into short-circuit protection. For proper diode selection, make sure that: 1) the diodes voltage rating is higher than each converter output; 2) the rated diode current can carry the short-circuit current; 3) the diodes do not overheat before the short is removed.

FIGURE 7. OUTPUT SERIES CONNECTIONS

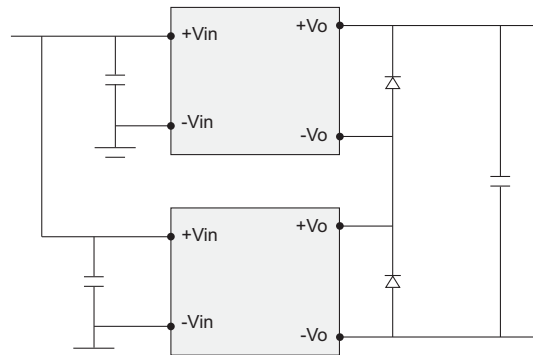

13. REMOTE OUTPUT ON/OFF CONTROL

The converter output can be enabled or disabled through the On/Off pin. The control logic is shown in this table. A common control circuit is shown below.

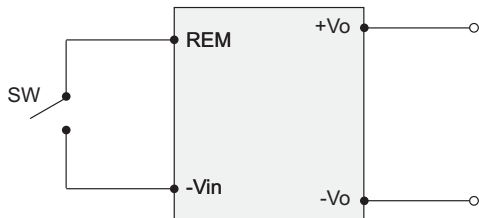

FIGURE 8. REMOTE ON/OFF CONTROL

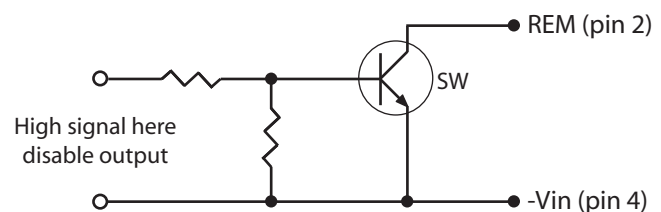

FIGURE 9. REMOTE ON/OFF CONTROL WITH TRANSISTOR SWITCH

Logic Table	Negative logic	Positive logic
SW Closed ($V_{REM} < 0.8\text{ V}$)	Output on	Output off
SW Open ($V_{REM} > 2.4\text{ V}$)	Output off	Output on

14. ISOLATION

The input and output of the converter are electrically isolated. If needed, an output terminal can be connected to an input terminal, resulting in the converter non-isolated.

PART NUMBER: VHB50W

DESCRIPTION: half-brick dc-dc converter

15. INPUT FILTERING AND EMI INTERFERENCE

The VHB50W converters have input capacitors that control input current ripple and the associated EMI interference. However, it has not been tested to a formal standard for conducted emissions. Additional filtering may be needed to ensure compliance to an EMI standard. Refer to FIGURE 10.1 and 10.2 for reference circuits.

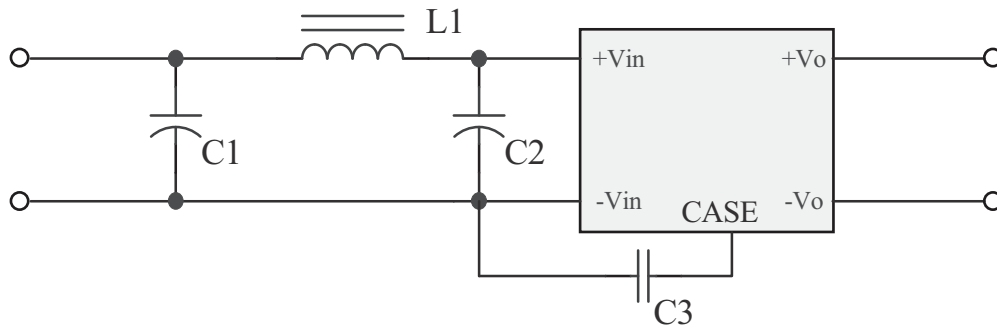
FIGURE 10.1. EMI FILTER FOR VHB50W, 3.3 ~ 24 V

VHB50W Series	C2	C3	C4	L1
EMI to meet class A	47 μ F/50V ESR<0.60	47 μ F/50V ESR<0.60	2200pF/2KV	2.5 μ H
EMI to meet class B	220 μ F/50V ESR<0.120	220 μ F/50V ESR<0.120	2200pF/2KV	1.5 μ H

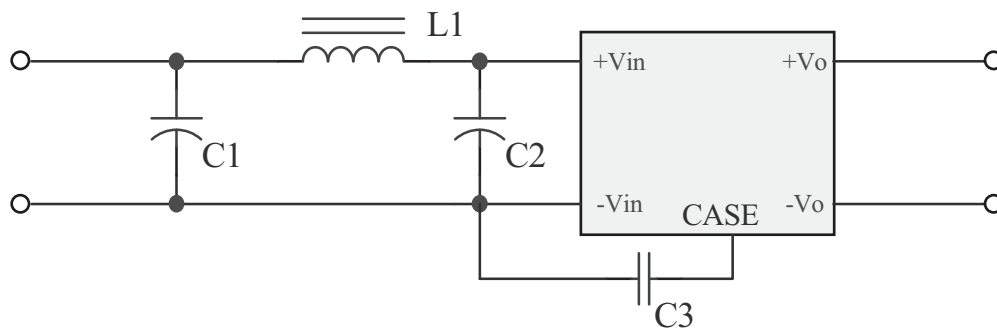
FIGURE 10.2A. EMI FILTER FOR VHB50W, 28 V (CLASS A)

Model No.	C1	C2	C3	L1
VHB50W-Q24-S28	100 μ F/50V KY	100 μ F/50V KY	2200pF/2KV	3.4 μ H
VHB50W-Q48-S28	100 μ F/100V KY	100 μ F/100V KY	2200pF/2KV	3.4 μ H

note: The recommended components are a starting point but not guaranteed for meeting these EMI requirements. More or less filtering may be required for a specific application or to meet other EMI standards, e.g.MIL-STD-461

PART NUMBER: VHB50W

DESCRIPTION: half-brick dc-dc converter

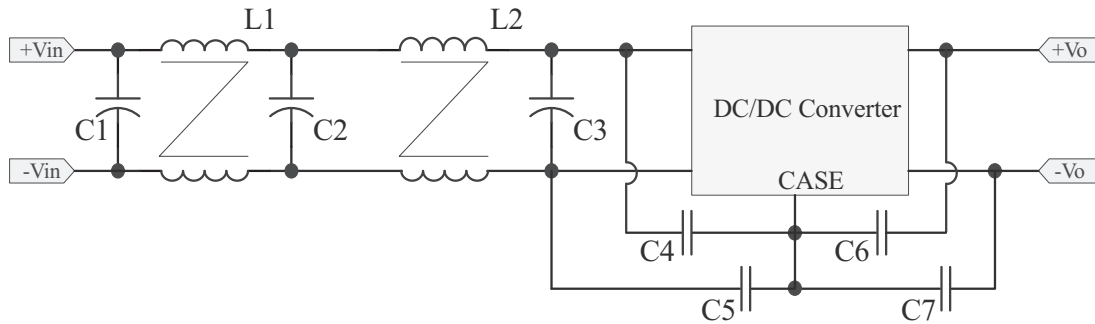
FIGURE 10.2B. EMI FILTER FOR VHB50W, 28 V (CLASS B)

Note:

Model No.	C1	C2	C3	C4	C5	C6	C7	L1	L2
VHB50W-Q24-S28	100uF/50V KY	100uF/50V KY	NC	NC	1000pF/2KV	NC	NC	0.12mH	0.34mH
VHB50W-Q48-S28	100uF/100V KY	100uF/100V KY	NC	NC	1000pF/2KV	NC	NC	0.12mH	0.34mH

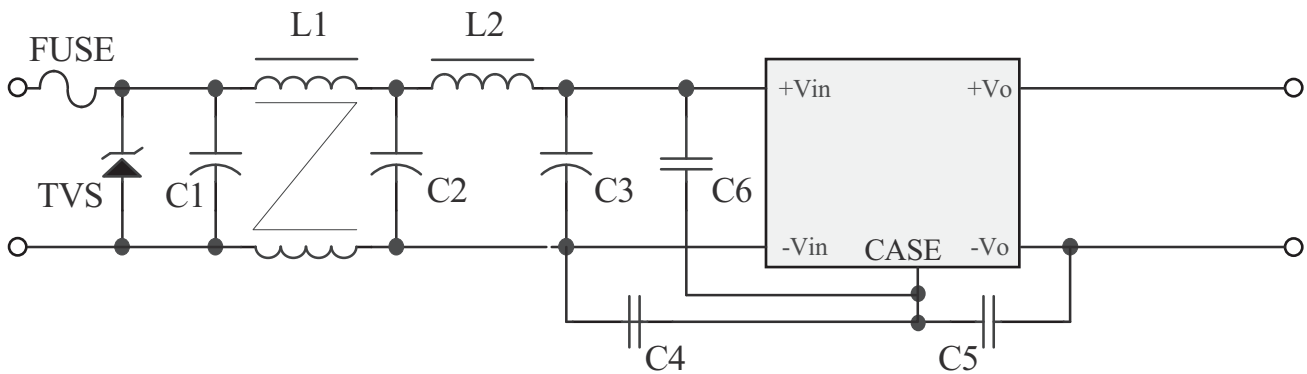
FIGURE 10.3. EMI FILTER FOR VHB50W, 48 V

EMI to meet class A	C1	C2	C3	C4	C5	C6	L1	L2
VHB50W-Q24-S48	NC	100uF/50V ESR<0.33Ω	100uF/50V ESR<0.33Ω	NC	NC	NC	Short	3.5uH
VHB50W-Q48-S48	NC	47uF/100V KMF	47uF/100V KMF	2200pF/2KV	NC	NC	Short	3.5uH
EMI to meet class B	C1	C2	C3	C4	C5	C6	L1	L2
VHB50W-Q24-S48	10uF/50V X7R,2220 Ceramic	100uF/50V ESR<0.33Ω	100uF/50V ESR<0.33Ω	4700pF/2KV	2200pF/2KV	1000pF/2KV	1.5mH	3.4uH
VHB50W-Q48-S48	47uF/100V KMF	47uF/100V KMF	47uF/100V KMF	4700pF/2KV	2200pF/2KV	1000pF/2KV	1.5mH	3.4uH

 note: The recommended components are a starting point but not guaranteed for meeting these EMI requirements. More or less filtering may be required for a specific application or to meet other EMI standards, e.g.MIL-STD-461

PART NUMBER: VHB50W

DESCRIPTION: half-brick dc-dc converter

16. OUTPUT FILTERING

The converter has built-in capacitors at the output to control ripple and noise. If desired, additional output capacitance can be introduced at the input to the powered equipment. Recommended starting point: one 10 μ F tantalum and one 1 μ F ceramic capacitor in parallel at the output.

17. OUTPUT NOISE MEASUREMENT SCHEMATIC

For proper output ripple and noise measurement, connect a 10 μ F tantalum and a 1 μ F ceramic capacitor across the output. Set the scope bandwidth to 20MHz. Probe directly off of one of the capacitors, using a small ground clip to minimize measurement error.

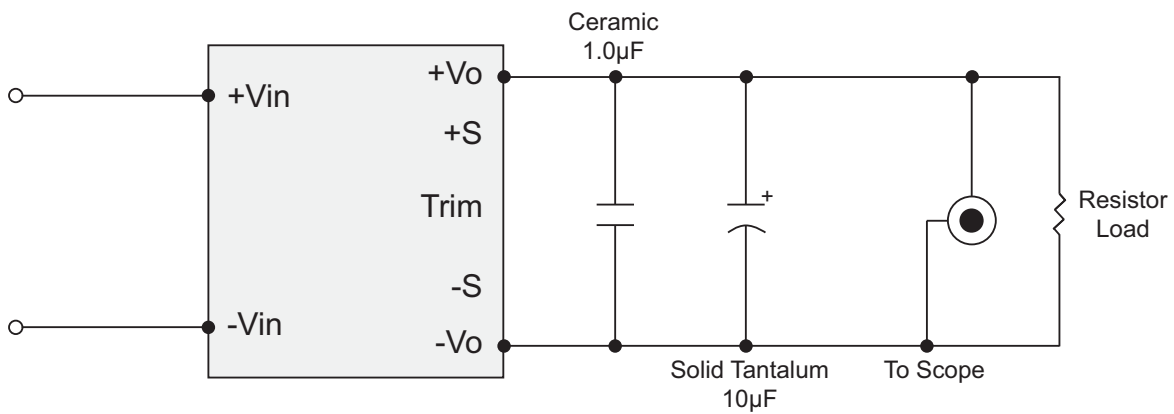

FIGURE 11. OUTPUT NOISE MEASUREMENT CIRCUIT