

## Integrated Digital Ambient Light Sensor with Interrupt Function

The ISL29023 is an integrated ambient and infrared light to digital converter with I<sup>2</sup>C (SMBus Compatible) Interface. Its advanced self-calibrated photodiode array emulates human eye response with excellent IR rejection. The on-chip ADC is capable of rejecting 50Hz and 60Hz flicker caused by artificial light sources. The lux range select feature allows users to program the lux range for optimized counts/lux.

For ambient light sensing, an internal 16-bit ADC has been designed based upon the charge-balancing technique. The ADC conversion time is nominally 90ms and is user adjustable from 11μs to 90ms, depending on oscillator frequency and ADC resolution. In normal operation, typical current consumption is 70μA. In order to further minimize power consumption, two power-down modes have been provided. If polling is chosen over continuous measurement of light, the auto-power-down function shuts down the whole chip after each ADC conversion for the measurement. The other power-down mode is controlled by software via the I<sup>2</sup>C interface. The power consumption can be reduced to less than 0.3μA when powered down.

The ISL29023 supports a software and hardware interrupt that remains asserted until the host clears it through I<sup>2</sup>C interface. Function of ADC conversion continues without stopping after interrupt is asserted.

Designed to operate on supplies from 2.25V to 3.63V with an I<sup>2</sup>C supply from 1.7V to 3.63V, the ISL29023 is specified for operation over the -40°C to +85°C ambient temperature range.

### Pinout

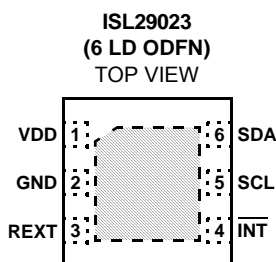

\*EXPOSED PAD CAN BE CONNECTED TO GND OR ELECTRICALLY ISOLATED

## Features

### Ambient Light Sensing

- Simple Output Code Directly Proportional to lux
- Variable Conversion Resolution up to 16-bits
- Adjustable Sensitivity up to 65 Counts per lux
- Selectable Range (via I<sup>2</sup>C)
  - Range 1 = 0.015 lux to 1,000 lux
  - Range 2 = 0.06 lux to 4,000 lux
  - Range 3 = 0.24 lux to 16,000 lux
  - Range 4 = 0.96 lux to 64,000 lux
- Integrated 50/60Hz Noise Rejection
- Temperature Compensated
- Works Under Various Light Sources, Including Sunlight

### Excellent Spectral Response

- Light Sensor Close to Human Eye Response
  - Excellent Light Sensor IR and UV Rejection

### Ultra Low Power

- 85μA Max Operating Current
- Software Shutdown and Automatic Shutdown
  - 0.3μA Max Shutdown Current

### Additional Features

- I<sup>2</sup>C and SMBus Compatible
- 1.7V to 3.63V Supply for I<sup>2</sup>C Interface
- 2.25V to 3.63V Sensor Power Supply
- Small Form Factor
  - 6 Ld 2.0x2.1x0.7mm ODFN Package
- Pb-Free (RoHS compliant)

## Applications

- Display and Keypad Dimming Adjustment for:
  - Mobile Devices: Smart Phone, PDA, GPS
  - Computing Devices: Notebook PC, Webpad
  - Consumer devices: LCD-TV, Digital Picture Frame, Digital Camera
- Industrial and Medical Light Sensing

**Ordering Information**

PART NUMBER (Note)	TEMP. RANGE (°C)	PACKAGE (Pb-Free)	PKG. DWG. #
ISL29023IROZ-T7*	-40 to +85	6 Ld ODFN	L6.2x2.1
ISL29023IROZ-EVALZ	Evaluation Board (Pb-free)		

\*Please refer to TB347 for details on reel specifications.

NOTE: These Intersil Pb-free plastic packaged products employ special Pb-free material sets; molding compounds/die attach materials and NiPdAu plate - e4 termination finish, which is RoHS compliant and compatible with both SnPb and Pb-free soldering operations. Intersil Pb-free products are MSL classified at Pb-free peak reflow temperatures that meet or exceed the Pb-free requirements of IPC/JEDEC J STD-020.

**Pin Descriptions**

PIN NUMBER	PIN NAME	DESCRIPTION	
1	VDD	Positive supply; connect this pin to a 2.25V to 3.63V supply.	
2	GND	Ground pin.	
3	REXT	External resistor pin for ADC reference; connect this pin to ground through a (nominal) 499kΩ resistor.	
4	INT	Interrupt pin; low for interrupt alarming. INT pin is open drain. INT remains asserted until the interrupt flag status bit is reset.	
5	SCL	i <sup>2</sup> C serial clock	The i <sup>2</sup> C bus lines can be pulled from 1.7V to above V <sub>DD</sub> , 3.63V max.
6	SDA	i <sup>2</sup> C serial data	
		Exposed pad connected to ground or electrically isolated.	

**Block Diagram**

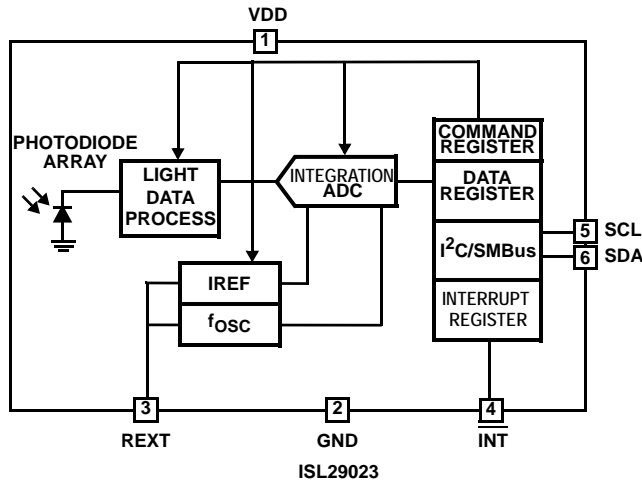

**Absolute Maximum Ratings** (T<sub>A</sub> = +25°C)

V <sub>DD</sub> Supply Voltage between V <sub>DD</sub> and GND	4.0V
I <sup>2</sup> C Bus (SCL, SDA) and INT Pin Voltage	-0.2V to 4.0V
I <sup>2</sup> C Bus (SCL, SDA) and INT Pin Current	<10mA
R <sub>EXT</sub> Pin Voltage	-0.2V to V <sub>DD</sub> +0.5V

**Thermal Information**

Thermal Resistance (Typical, Note 1)	θ <sub>JA</sub> (°C/W)
6 Ld ODFN	90
Maximum Die Temperature	+90°C
Storage Temperature	-40°C to +100°C
Operating Temperature	-40°C to +85°C
Pb-Free Reflow Profile	see link below
<a href="http://www.intersil.com/pbfree/Pb-FreeReflow.asp">http://www.intersil.com/pbfree/Pb-FreeReflow.asp</a>	

CAUTION: Do not operate at or near the maximum ratings listed for extended periods of time. Exposure to such conditions may adversely impact product reliability and result in failures not covered by warranty.

NOTE:

1. θ<sub>JA</sub> is measured in free air with the component mounted on a high effective thermal conductivity test board with “direct attach” features. See Tech Brief TB379.

IMPORTANT NOTE: All parameters having Min/Max specifications are guaranteed. Typical values are for information purposes only. Unless otherwise noted, all tests are at the specified temperature and are pulsed tests, therefore: T<sub>J</sub> = T<sub>C</sub> = T<sub>A</sub>

**Electrical Specifications** V<sub>DD</sub> = 3V, T<sub>A</sub> = +25°C, R<sub>EXT</sub> = 499kΩ 1% tolerance, 16-bit ADC operation, unless otherwise specified.

PARAMETER	DESCRIPTION	CONDITION	MIN	TYP	MAX	UNIT
V <sub>DD</sub>	Power Supply Range		2.25		3.63	V
I <sub>DD</sub>	Supply Current			70	85	μA
I <sub>DD1</sub>	Supply Current when Powered Down	Software disabled or auto power-down		0.01	0.3	μA
V <sub>I<sup>2</sup>C</sub>	Supply Voltage Range for I <sup>2</sup> C Interface		1.7		3.63	V
f <sub>OSC</sub>	Internal Oscillator Frequency		675	750	825	kHz
t <sub>int</sub>	ADC Integration/Conversion Time	16-bit ADC data		90		ms
F <sub>I<sup>2</sup>C</sub>	I <sup>2</sup> C Clock Rate Range			1 to 400		kHz
DATA_0	Count Output When Dark	E = 0 lux, Range 1 (1k lux)		1	5	Counts
DATA_F	Full Scale ADC Code				65535	Counts
ΔDATA DATA	Count Output Variation Over Three Light Sources: Fluorescent, Incandescent and Sunlight	Ambient light sensing		±10		%
DATA_1	Light Count Output With LSB of 0.015 lux/count	E = 300 lux, Fluorescent light (Note 2), Ambient light sensing, Range 1 (1k lux)	15000	20000	25000	Counts
DATA_2	Light Count Output With LSB of 0.06 lux/count	E = 300 lux, Fluorescent light (Note 2), Ambient light sensing, Range 2 (4k lux)		5000		Counts
DATA_3	Light Count Output With LSB of 0.24 lux/count	E = 300 lux, Fluorescent light (Note 2), Ambient light sensing, Range 3 (16k lux)		1250		Counts
DATA_4	Light Count Output With LSB of 0.96 lux/count	E = 300 lux, Fluorescent light (Note 2), Ambient light sensing, Range 4 (64k lux)		312		Counts
DATA_IR1	Infrared Count Output	E = 210 lux, Sunlight (Note 3), IR sensing, Range 1	15000	20000	25000	
DATA_IR2	Infrared Count Output	E = 210 lux, Sunlight (Note 3), IR sensing, Range 2		5000		
DATA_IR3	Infrared Count Output	E = 210 lux, Sunlight (Note 3), IR sensing, Range 3		1250		
DATA_IR4	Infrared Count Output	E = 210 lux, Sunlight (Note 3), IR sensing, Range 4		312		
V <sub>REF</sub>	Voltage of R <sub>EXT</sub> Pin			0.52		V
V <sub>IL</sub>	SCL and SDA Input Low Voltage				0.55	V
V <sub>IH</sub>	SCL and SDA Input High Voltage		1.25			V
I <sub>SDA</sub>	SDA Current Sinking Capability		4	5		mA
I <sub>INT</sub>	INT Current Sinking Capability		4	5		mA

NOTES:

2. 550nm green LED is used in production test. The 550nm LED irradiance is calibrated to produce the same DATA count against an illuminance level of 300 lux fluorescent light.
3. 850nm IR LED is used in production test. The 850nm LED irradiance is calibrated to produce the same DATA\_IR count against an illuminance level of 210 lux sunlight at sea level.

## Principles of Operation

### Photodiodes and ADC

The ISL29023 contains two photodiode arrays which convert light into current. The spectral response for ambient light sensing and IR sensing is shown in Figure 5 in the performance curves section. After light is converted to current during the light signal process, the current output is converted to digital by a built-in 16-bit Analog-to-Digital Converter (ADC). An I<sup>2</sup>C command reads the ambient light or IR intensity in counts.

The converter is a charge-balancing integrating type 16-bit ADC. The chosen method for conversion is best for converting small current signals in the presence of an AC periodic noise. A 100ms integration time, for instance, highly rejects 50Hz and 60Hz power line noise simultaneously. See "Integration and Conversion Time" on page 7.

The built-in ADC offers user flexibility in integration time or conversion time. There are two timing modes: Internal Timing Mode and External Timing Mode. In Internal Timing Mode, integration time is determined by an internal oscillator ( $f_{OSC}$ ), and the n-bit ( $n = 4, 8, 12, 16$ ) counter inside the ADC. In External Timing Mode, integration time is determined by the time between two consecutive I<sup>2</sup>C External Timing Mode commands. A good balancing act of integration time and resolution (depending on the application) is required for optimal results.

The ADC has I<sup>2</sup>C programmable range select to dynamically accommodate various lighting conditions. For very dim conditions, the ADC can be configured at its lowest range (Range 1) in the ambient light sensing.

### Low-Power Operation

The ISL29023 initial operation is at the power-down mode after a supply voltage is provided. The data registers contain the default value of 0. When the ISL29023 receives an I<sup>2</sup>C command to do a one-time measurement from an I<sup>2</sup>C master, it will start ADC conversion with light sensing. It will go to the power-down mode automatically after one conversion is finished and keep the conversion data available for the master to fetch anytime afterwards. The ISL29023 will continuously do ADC conversion with light sensing if it receives an I<sup>2</sup>C command of continuous measurement. It will continuously update the data registers with the latest conversion data. It will go to the power-down mode after it receives the I<sup>2</sup>C command of power-down.

### Ambient Light and IR Sensing

There are four operational modes in ISL29023: Programmable ALS once with auto power-down, programmable IR sensing once with auto power-down, programmable continuous ALS sensing and programmable continuous IR sensing. These four modes can be programmed in series to fulfill the application needs. The detailed program configuration is listed in "Command Register I 00(hex)" on page 5.

When the part is programmed for ambient light sensing, the ambient light with wavelength within the "Ambient Light Sensing" spectral response curve in Figure 5 is converted into current. With ADC, the current is converted to an unsigned n-bit (up to 16 bits) digital output.

When the part is programmed for infrared (IR) sensing, the IR light with wavelength within the "IR Sensing" spectral response curve in Figure 5 is converted into current. With ADC, the current is converted to an unsigned n-bit (up to 16-bits) digital output.

### Interrupt Function

The active low interrupt pin is an open drain pull-down configuration. The interrupt pin serves as an alarm or monitoring function to determine whether the ambient light level exceeds the upper threshold or goes below the lower threshold. It should be noted that the function of ADC conversion continues without stopping after interrupt is asserted. If the user needs to read the ADC count that triggers the interrupt, the reading should be done before the data registers are refreshed by the following conversions. The user can also configure the persistency of the interrupt pin. This reduces the possibility of false triggers, such as noise or sudden spikes in ambient light conditions. An unexpected camera flash, for example, can be ignored by setting the persistency to 8 integration cycles.

### I<sup>2</sup>C Interface

There are eight 8-bit registers available inside the ISL29023. The two command registers define the operation of the device. The command registers do not change until the registers are overwritten. The two 8-bit data Read Only registers are for the ADC output. The data registers contain the ADC's latest digital output, or the number of clock cycles in the previous integration period.

The ISL29023's I<sup>2</sup>C interface slave address is internally hard-wired as 1000100. When 1000100x with x as R or  $\overline{W}$  is sent after the Start condition, this device compares the first 7 bits of this byte to its address and matches.

Figure 1 shows a sample one-byte read. Figure 2 shows a sample one-byte write. The I<sup>2</sup>C bus master always drives the SCL (clock) line, while either the master or the slave can drive the SDA (data) line. Figure 2 shows a sample write. Every I<sup>2</sup>C transaction begins with the master asserting a start condition (SDA falling while SCL remains high). The following byte is driven by the master, and includes the slave address and read/write bit. The receiving device is responsible for pulling SDA low during the acknowledgement period. Every I<sup>2</sup>C transaction ends with the master asserting a stop condition (SDA rising while SCL remains high).

For more information about the I<sup>2</sup>C standard, please consult the Philips™ I<sup>2</sup>C specification documents.

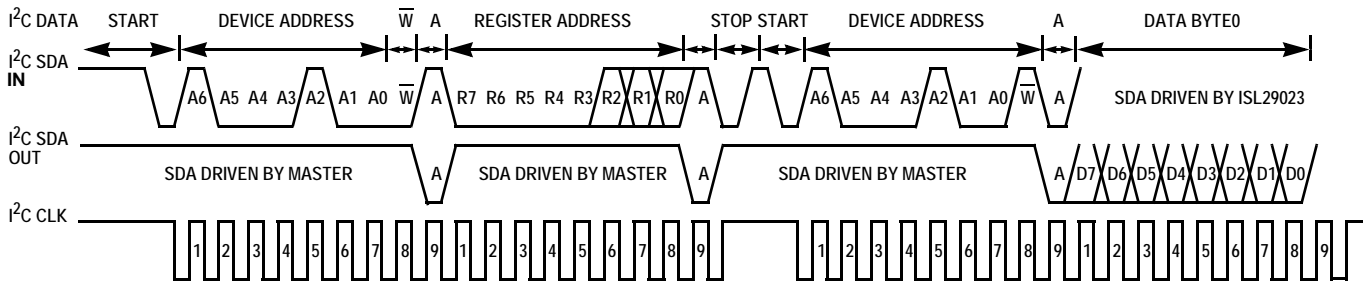

FIGURE 1. I<sup>2</sup>C READ TIMING DIAGRAM SAMPLE

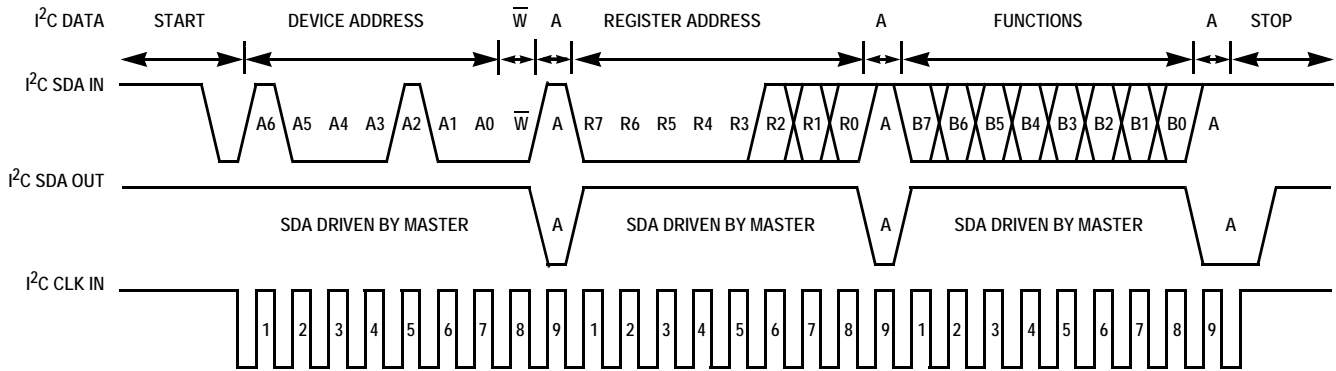

FIGURE 2. I<sup>2</sup>C WRITE TIMING DIAGRAM SAMPLE

## Register Set

There are eight registers that are available in the ISL29023. Table 1 summarizes their functions.

TABLE 1. REGISTER SET

ADDR	REG NAME	BIT								DEFAULT
		7	6	5	4	3	2	1	0	
00h	COMMANDI	OP2	OP1	OP0	0	0	FLAG	PRST1	PRST0	00h
01h	COMMANDII	0	0	0	0	RES1	RES0	RANGE1	RANGE0	00h
02h	DATA <sub>LSB</sub>	D7	D6	D5	D4	D3	D2	D1	D0	00h
03h	DATA <sub>MSB</sub>	D15	D14	D13	D12	D11	D10	D9	D8	00h
04h	INT_LT_LSB	TL7	TL6	TL5	TL4	TL3	TL2	TL1	TL0	00h
05h	INT_LT_MSB	TL15	TL14	TL13	TL12	TL11	TL10	TL9	TL8	00h
06h	INT_HT_LSB	TH7	TH6	TH5	TH4	TH3	TH2	TH1	TH0	FFh
07h	INT_HT_MSB	TH15	TH14	TH13	TH12	TH11	TH10	TH9	TH8	FFh

### Command Register I 00(hex)

The first command register has the following functions:

1. Operation Mode: Bits 7, 6, and 5. These three bits determine the operation mode of the device.

TABLE 2. OPERATION MODE

BITS 7 TO 5	OPERATION
000	Power-down the device
001	ALS once
010	IR once
100	Reserved (Do not use)
101	ALS continuous
110	IR continuous
111	Reserved (Do not use)

2. Interrupt flag; Bit 2. This is the status bit of the interrupt. The bit is set to logic high when the interrupt thresholds have been triggered (out of threshold window), and logic low when not yet triggered. Once activated and the interrupt is triggered, the INT pin goes low and the interrupt status bit goes high until the status bit is polled through the I<sup>2</sup>C read command. Both the INT output and the interrupt status bit are automatically cleared at the end of the 8-bit (00h) command register transfer.

TABLE 3. INTERRUPT FLAG

BIT 2	OPERATION
0	Interrupt is cleared or not triggered yet
1	Interrupt is triggered

3. Interrupt persist; Bits 1 and 0. The interrupt pin and the interrupt flag are triggered/set when the data sensor reading is out of the interrupt threshold window after m consecutive number of integration cycles. The interrupt persist bits determine m.

TABLE 4. INTERRUPT PERSIST

BIT 1:0	NUMBER OF INTEGRATION CYCLES
00	1
01	4
10	8
11	16

### Command Register II 01(hex)

The second command register has the following functions:

1. Resolution: Bits 3 and 2. Bits 3 and 2 determine the ADC's resolution and the number of clock cycles per conversion. Changing the number of clock cycles does more than just change the resolution of the device; it also changes the integration time, which is the period the device's analog-to-digital (A/D) converter samples the photodiode current signal for a measurement.

TABLE 5. ADC RESOLUTION DATA WIDTH

BITS 3:2	NUMBER OF CLOCK CYCLES	n-BIT ADC
00	$2^{16} = 65,536$	16
01	$2^{12} = 4,096$	12
10	$2^8 = 256$	8
11	$2^4 = 16$	4

2. Range: Bits 1 and 0. The Full Scale Range (FSR) can be adjusted via I<sup>2</sup>C using Bits 1 and 0. Table 6 lists the possible values of FSR for the 499kΩ R<sub>EXT</sub> resistor.

TABLE 6. RANGE/FSR LUX

BITS 1:0	k	RANGE(k)	FSR (LUX) @ ALS SENSING	FSR @ IR SENSING
00	1	Range1	1,000	Refer to page 3
01	2	Range2	4,000	Refer to page 3
10	3	Range3	16,000	Refer to page 3
11	4	Range4	64,000	Refer to page 3

### Data Registers (02 hex and 03 hex)

The device has two 8-bit read-only registers to hold the data from LSB to MSB for ADC. The most significant bit (MSB) is accessed at 03 hex, and the least significant bit (LSB) is accessed at 02 hex. For 16-bit resolution, the data is from D0 to D15; for 12-bit resolution, the data is from D0 to D11; for 8-bit resolution, the data is from D0 to D7. The registers are refreshed after every conversion cycle.

TABLE 7. DATA REGISTERS

ADDRESS (hex)	CONTENTS
02	D0 is LSB for 4, 8, 12 or 16-bit resolution; D3 is MSB for 4-bit resolution; D7 is MSB for 8-bit resolution
03	D15 is MSB for 16-bit resolution; D11 is MSB for 12-bit resolution

### Interrupt Registers (04, 05, 06 and 07 hex)

Registers 04 and 05 hex set the low (LO) threshold for the interrupt pin and the interrupt flag. 04 hex is the LSB and 05 hex is the MSB. By default, the Interrupt threshold LO is 00 hex for both LSB and MSB.

Registers 06 and 07 hex set the high (HI) threshold for the interrupt pin and the interrupt flag. 06 hex is the LSB and 07 hex is the MSB. By default, the Interrupt threshold HI is FF hex for both LSB and MSB.

### Calculating Lux

The ISL29023's ADC output codes, DATA, are directly proportional to lux in the ambient light sensing.

$$E_{\text{cal}} = \alpha \times \text{DATA} \quad (\text{EQ. 1})$$

Here,  $E_{\text{cal}}$  is the calculated lux reading. The constant  $\alpha$  is determined by the Full Scale Range and the ADC's maximum output counts. The constant is independent of the light sources (fluorescent, incandescent and sunlight) because the light sources' IR component is removed during the light signal process. The constant can also be viewed as the sensitivity (the smallest lux measurement the device can measure).

$$\alpha = \frac{\text{Range}(k)}{\text{Count}_{\text{max}}} \quad (\text{EQ. 2})$$

Here, Range(k) is defined in Table 6.  $\text{Count}_{\text{max}}$  is the maximum output counts from the ADC.

The transfer function used for n-bits ADC becomes:

$$E_{\text{cal}} = \frac{\text{Range}(k)}{2^n} \times \text{DATA} \quad (\text{EQ. 3})$$

Here,  $n = 4, 8, 12$  or  $16$ . This is the number of ADC bits programmed in the command register.  $2^n$  represents the maximum number of counts possible from the ADC output. Data is the ADC output stored in the data registers (02 hex and 03 hex).



### Integration and Conversion Time

The ADC resolution and  $f_{OSC}$  determine the integration time,  $t_{int}$ .

$$t_{int} = 2^n \times \frac{1}{f_{OSC}} = 2^n \times \frac{R_{EXT}}{725\text{kHz} \times 499\text{k}\Omega} \quad (\text{EQ. 4})$$

where  $n$  is the number of bits of resolution and  $n = 4, 8, 12$  or  $16$ . Therefore,  $2^n$  is the number of clock cycles.  $n$  can be programmed at the command register 01(hex) bits 3 and 2.

TABLE 8. INTEGRATION TIME OF n-BIT ADC

$R_{EXT}$ (k $\Omega$ )	n = 16-BIT	n = 12-BIT	n = 8-BIT	n = 4-BIT
250	45ms	2.8ms	176 $\mu$ s	11 $\mu$ s
499**	90ms	5.6ms	352 $\mu$ s	22 $\mu$ s

\*\*Recommended  $R_{EXT}$  resistor value

### External Scaling Resistor $R_{EXT}$ for $f_{OSC}$ and Range

The ISL29023 uses an external resistor  $R_{EXT}$  to fix its internal oscillator frequency  $f_{OSC}$  and the light sensing range, Range.  $f_{OSC}$  and Range are inversely proportional to  $R_{EXT}$ . For user simplicity, the proportionality constant is referenced to 499k $\Omega$ :

$$\text{Range} = \frac{499\text{k}\Omega}{R_{EXT}} \times \text{Range(k)} \quad (\text{EQ. 5})$$

$$f_{OSC} = \frac{499\text{k}\Omega}{R_{EXT}} \times 725\text{kHz} \quad (\text{EQ. 6})$$

### Noise Rejection

In general, integrating type ADC's have excellent noise-rejection characteristics for periodic noise sources whose frequency is an integer multiple of the conversion rate. For instance, a 60Hz AC unwanted signal's sum from 0ms to  $k \times 16.66\text{ms}$  ( $k = 1, 2, \dots, k_i$ ) is zero. Similarly, setting the device's integration time to be an integer multiple of the periodic noise signal, greatly improves the light sensor output signal in the presence of noise.

### ADC Output in IR Sensing

The ISL29023's ADC output codes, DATA, are directly proportional to the IR intensity received in the IR sensing.

$$\text{DATA}_{IR} = \beta \times E_{IR} \quad (\text{EQ. 7})$$

Here,  $E_{IR}$  is the received IR intensity. The constant  $\beta$  changes with the spectrum of background IR noise, such as sunlight and incandescent light. The  $\beta$  also changes with the ADC's range and resolution selections.

### Suggested PCB Footprint

It is important that the users check the "Surface Mount Assembly Guidelines for Optical Dual FlatPack No Lead (ODFN) Package" before starting ODFN product board mounting.

<http://www.intersil.com/data/tb/TB477.pdf>

### Layout Considerations

The ISL29023 is relatively insensitive to layout. Like other I<sup>2</sup>C devices, it is intended to provide excellent performance even in significantly noisy environments. There are only a few considerations that will ensure best performance.

Route the supply and I<sup>2</sup>C traces as far as possible from all sources of noise. Use two power-supply decoupling capacitors, 1 $\mu$ F and 0.1 $\mu$ F, placed close to the device.

### Typical Circuit

A typical application for the ISL29023 is shown in Figure 3. The ISL29023's I<sup>2</sup>C address is internally hardwired as 1000100. The device can be tied onto a system's I<sup>2</sup>C bus together with other I<sup>2</sup>C compliant devices.

### Soldering Considerations

Convection heating is recommended for reflow soldering; direct-infrared heating is not recommended. The plastic ODFN package does not require a custom reflow soldering profile, and is qualified to +260°C. A standard reflow soldering profile with a +260°C maximum is recommended.

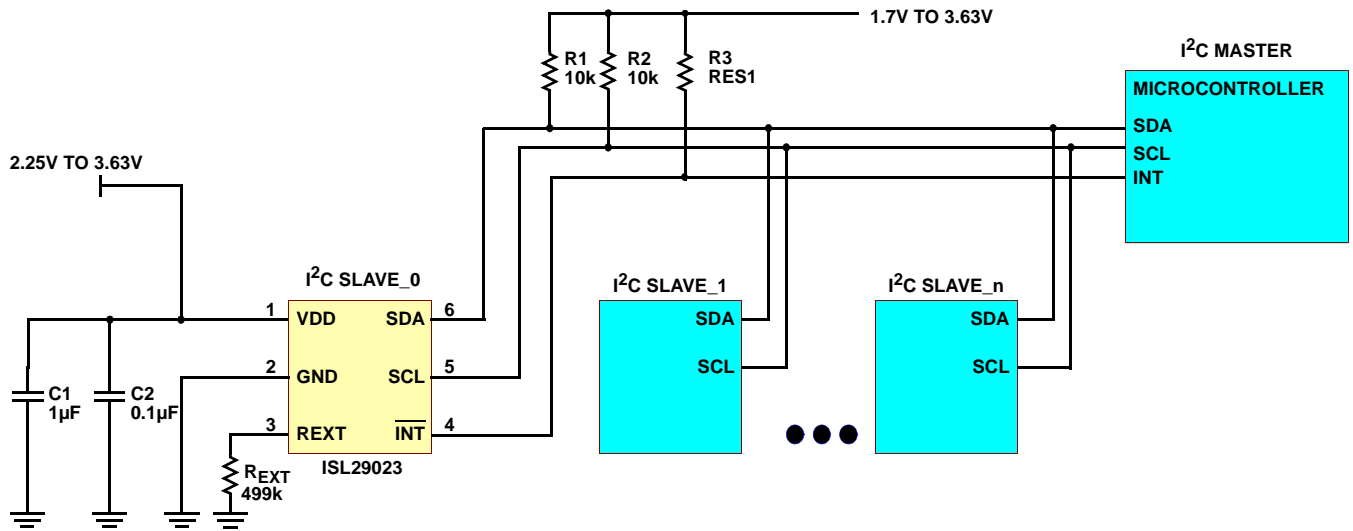

FIGURE 3. ISL29023 TYPICAL CIRCUIT



**Typical Performance Curves** ( $V_{DD} = 3V, R_{EXT} = 499k\Omega$ )

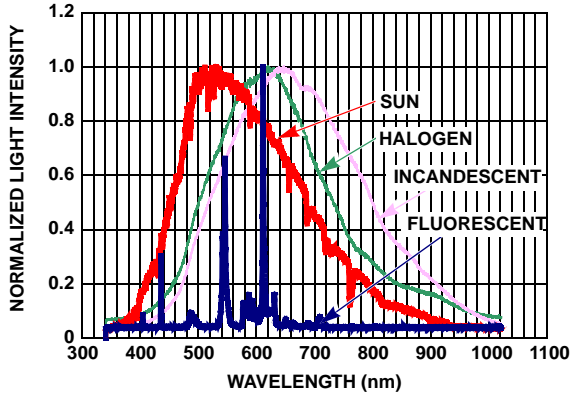

FIGURE 4. NORMALIZED SPECTRAL RESPONSE OF LIGHT SOURCES

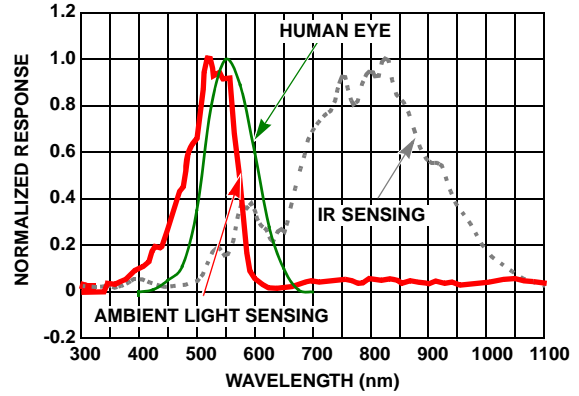

FIGURE 5. NORMALIZED SPECTRAL RESPONSE FOR AMBIENT LIGHT SENSING AND IR SENSING

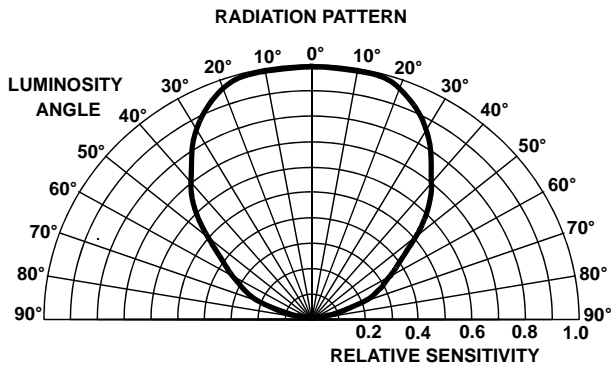

FIGURE 6. RADIATION PATTERN

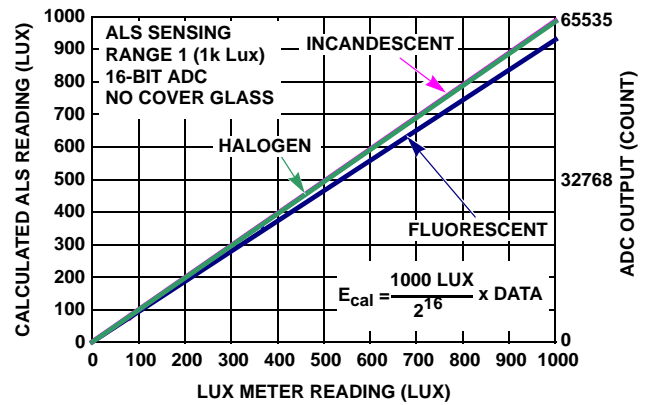

FIGURE 7. SENSITIVITY TO THREE LIGHT SOURCES

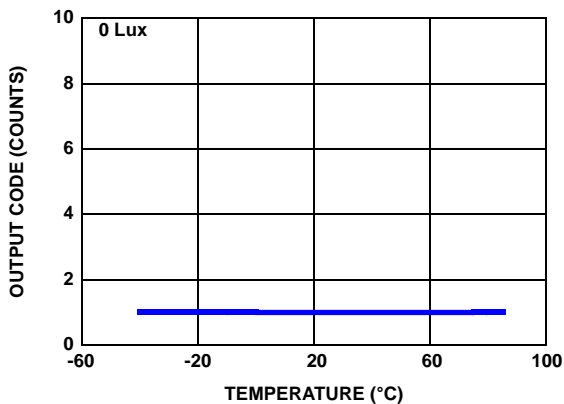

FIGURE 8. OUTPUT CODE FOR 0 LUX vs TEMPERATURE

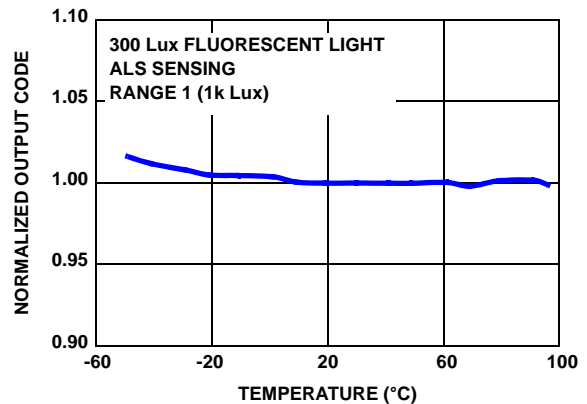

FIGURE 9. OUTPUT CODE vs TEMPERATURE

Typical Performance Curves ( $V_{DD} = 3V$ ,  $R_{EXT} = 499k\Omega$ ) (Continued)

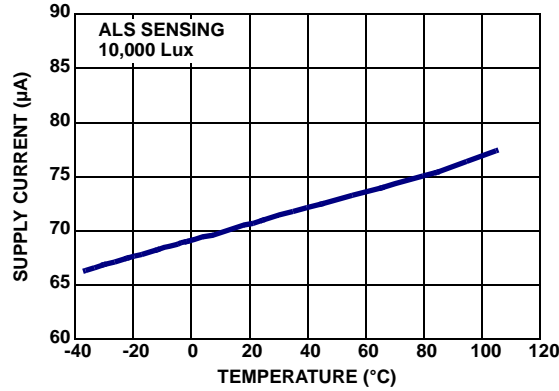

FIGURE 10. SUPPLY CURRENT vs TEMPERATURE IN ALS SENSING

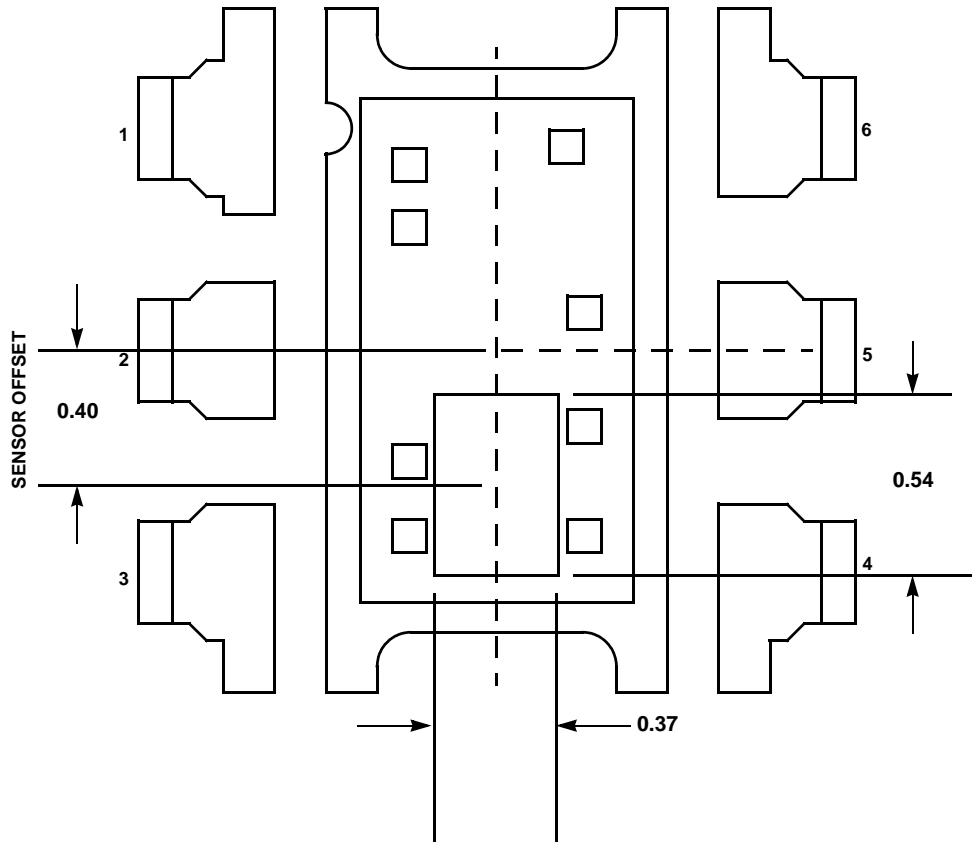

FIGURE 11. 6 LD ODFN SENSOR LOCATION OUTLINE

All Intersil U.S. products are manufactured, assembled and tested utilizing ISO9000 quality systems. Intersil Corporation's quality certifications can be viewed at [www.intersil.com/design/quality](http://www.intersil.com/design/quality)

*Intersil products are sold by description only. Intersil Corporation reserves the right to make changes in circuit design, software and/or specifications at any time without notice. Accordingly, the reader is cautioned to verify that data sheets are current before placing orders. Information furnished by Intersil is believed to be accurate and reliable. However, no responsibility is assumed by Intersil or its subsidiaries for its use; nor for any infringements of patents or other rights of third parties which may result from its use. No license is granted by implication or otherwise under any patent or patent rights of Intersil or its subsidiaries.*

For information regarding Intersil Corporation and its products, see [www.intersil.com](http://www.intersil.com)

# Package Outline Drawing

## L6.2x2.1

6 LEAD OPTICAL DUAL FLAT NO-LEAD PLASTIC PACKAGE (ODFN)

Rev 0, 9/06

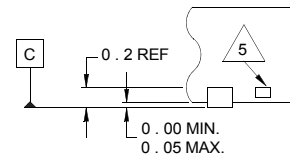
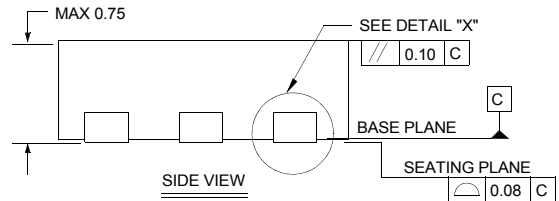
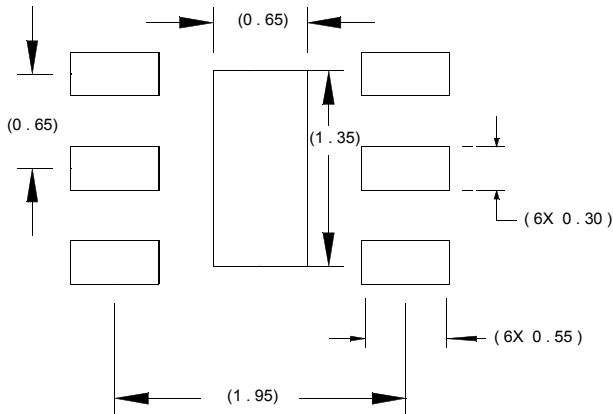
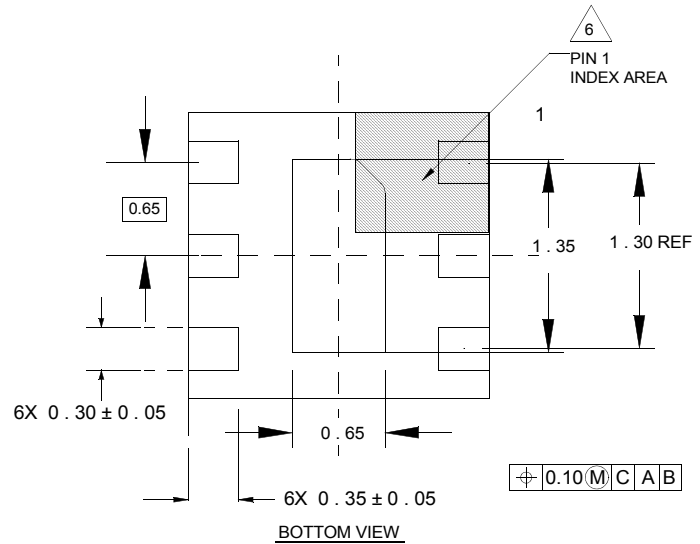
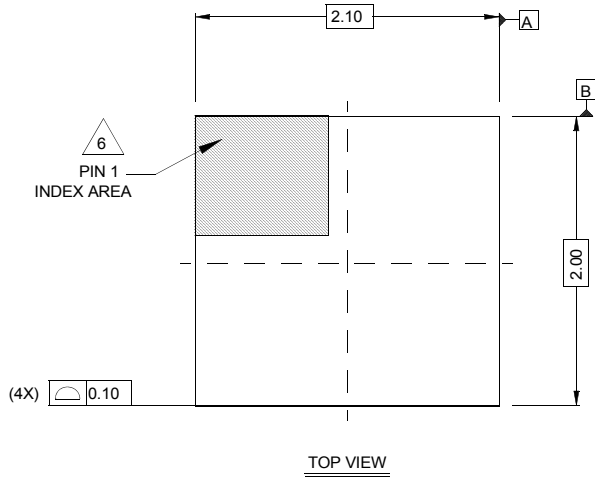

NOTES:

1. Dimensions are in millimeters.  
Dimensions in ( ) for Reference Only.
2. Dimensioning and tolerancing conform to AMSE Y14.5m-1994.
3. Unless otherwise specified, tolerance : Decimal  $\pm 0.05$
4. Dimension b applies to the metallized terminal and is measured between 0.15mm and 0.30mm from the terminal tip.
5. Tiebar shown (if present) is a non-functional feature.
6. The configuration of the pin #1 identifier is optional, but must be located within the zone indicated. The pin #1 identifier may be either a mold or mark feature.