

### 1 Introduction

This user manual describes the STEVAL-IFS002V2 STR9 MEMS demonstration board hardware. As well as the block diagram and schematics of the demonstration board, a bill of materials and assembly instructions are also included.

The STR9 MEMS demonstration board provides an STR9 dongle-based application with a MEMS sensor. MEMS (micro-electro-mechanical system) exploits the mechanical properties of silicon to create movable structures that, in the case of MEMS-based motion sensors, are able to sense motion (acceleration or vibration) in distinct directions.

The demonstration board used here can be assembled with several types of digital MEMS sensors as well as analog ones. For data storage, there is assembly space for ST serial Flash. The integration of voltage regulators and operational amplifiers is optional and depends on the intended chip usage.

**Figure 1. STR9 MEMS demonstration board**

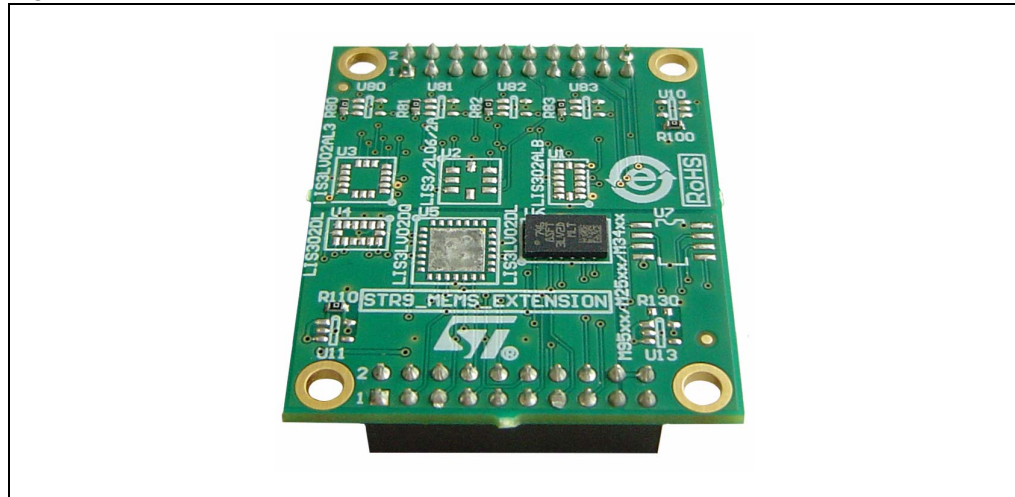

---

# Contents

<b>1</b>	<b>Introduction</b> .....	<b>1</b>
<b>2</b>	<b>STR9 MEMS demonstration board block diagram</b> .....	<b>5</b>
<b>3</b>	<b>STR9 MEMS demonstration board schematics</b> .....	<b>6</b>
<b>4</b>	<b>MEMS footprints</b> .....	<b>8</b>
4.1	LGA8 package .....	8
4.2	LGA14 package .....	9
4.3	LGA16 (D) package .....	10
4.4	LGA16 (A) package .....	11
4.5	QFN28 package .....	12
<b>5</b>	<b>PCB layout</b> .....	<b>13</b>
<b>6</b>	<b>Bill of materials and assembly instructions</b> .....	<b>14</b>
6.1	Assembly information for analog MEMS .....	14
6.2	Assembly information for digital MEMS .....	14
6.3	Assembly information for serial memory .....	15
<b>7</b>	<b>Revision history</b> .....	<b>19</b>

## List of tables

Table 1.	Mechanical data (LGA8 package) . . . . .	8
Table 2.	Mechanical data (LGA14 package) . . . . .	9
Table 3.	Mechanical data (LGA16 (D) package) . . . . .	10
Table 4.	Mechanical data (LAG16 (A) package) . . . . .	11
Table 5.	Mechanical data (QFN28 package) . . . . .	12
Table 6.	Voltage regulator for analog MEMS . . . . .	15
Table 7.	Voltage regulator for digital MEMS . . . . .	15
Table 8.	Voltage regulator for memory . . . . .	15
Table 9.	Analog MEMS . . . . .	16
Table 10.	Digital MEMS, . . . . .	16
Table 11.	Memory . . . . .	17
Table 12.	Operational amplifier X-axis for analog MEMS . . . . .	17
Table 13.	Operational amplifier Y-axis for analog MEMS . . . . .	17
Table 14.	Operational amplifier Z-axis for analog MEMS . . . . .	17
Table 15.	Operational amplifier XYZ-axes for analog MEMS . . . . .	18
Table 16.	Document revision history . . . . .	19

## List of figures

Figure 1.	STR9 MEMS demonstration board . . . . .	1
Figure 2.	STR9 MEMS demonstration board block diagram . . . . .	5
Figure 3.	Schematics - analog and digital MEMS . . . . .	6
Figure 4.	Schematics - I <sup>2</sup> C/SPI Flash/EEPROM device, amplifier, stabilizers . . . . .	7
Figure 5.	MEMS footprint (LGA8 package) . . . . .	8
Figure 6.	MEMS footprint (LGA14 package) . . . . .	9
Figure 7.	MEMS footprint (LGA16 (D) package) . . . . .	10
Figure 8.	MEMS footprint (LAG16 (A) package) . . . . .	11
Figure 9.	MEMS footprint (QFN28 package) . . . . .	12
Figure 10.	Top view . . . . .	13
Figure 11.	Bottom view . . . . .	13

## 2 STR9 MEMS demonstration board block diagram

This board is based on STR9 dongle. The main board features are the following:

- Analog MEMS:
  - LGA8 (LIS2L02AL, LIS2L06AL, LIS3L02AL, LIS3L06AL)
  - LGA14 (LIS302ALB)
  - LGA16 (LIS3L02AL3)
- Digital MEMS:
  - LGA14 (LIS302DL)
  - LGA16 (LIS3LV02DL)
  - QFN28 (LIS3L02DQ, LIS3LV02DQ)
- Serial Flash/EEPROM device
  - SO8 (M95xx, M25xx, M34xx)
- Voltage regulator
  - SOT23-5L (LD2980CMxx)
- Operational amplifier
  - SOT23-5L (TS507ILT)

*Figure 2* shows the STR9 MEMS demonstration board block diagram.

**Figure 2. STR9 MEMS demonstration board block diagram**

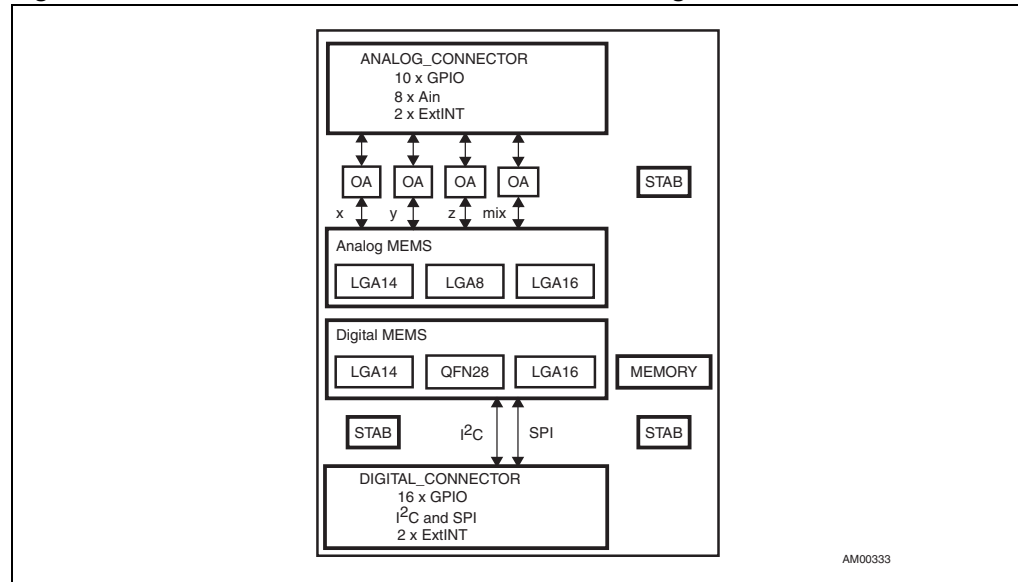

### 3 STR9 MEMS demonstration board schematics

Figure 3. Schematics - analog and digital MEMS

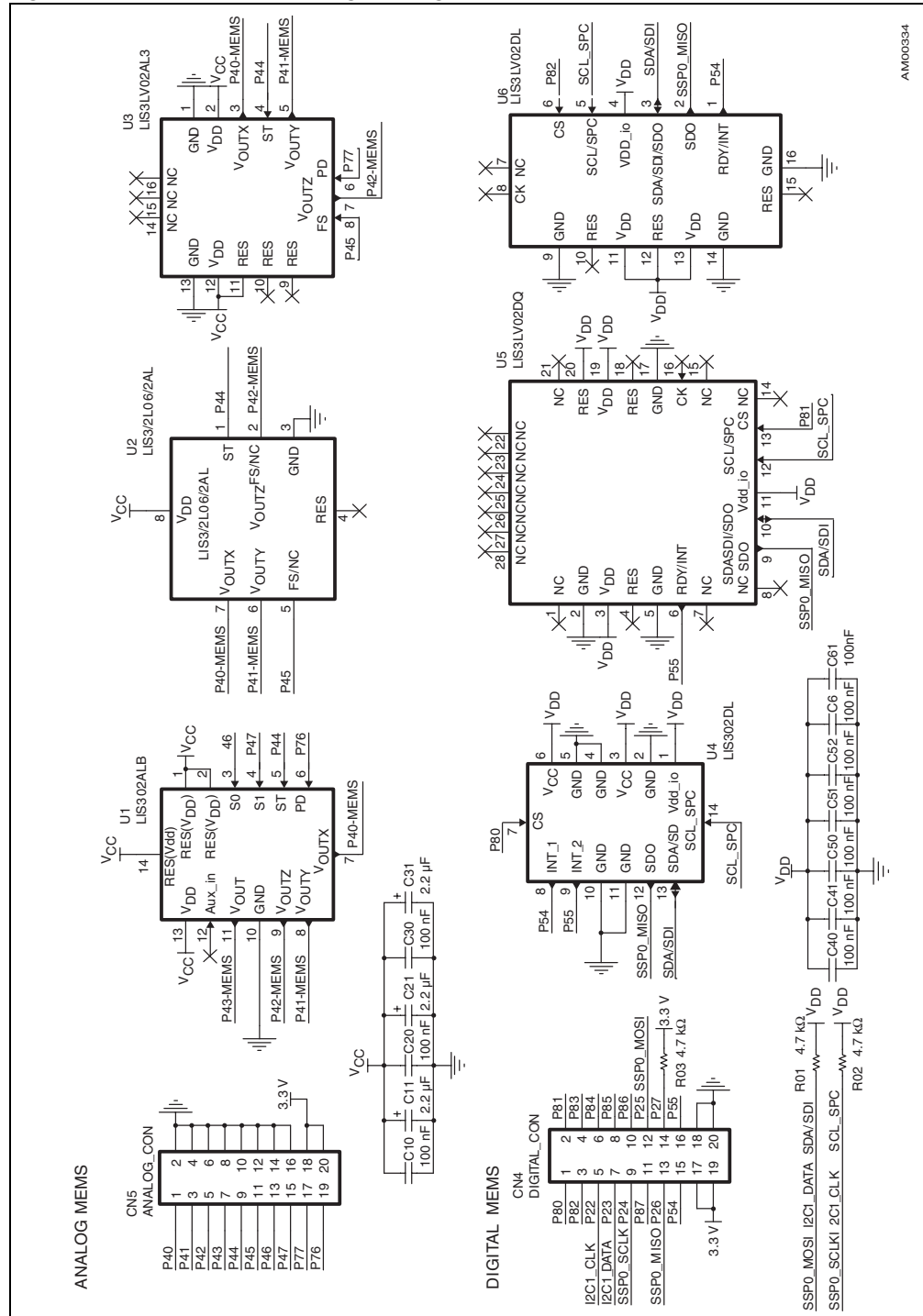

AM00334



Figure 4. Schematics - I<sup>2</sup>C/SPI Flash/EEPROM device, amplifier, stabilizers

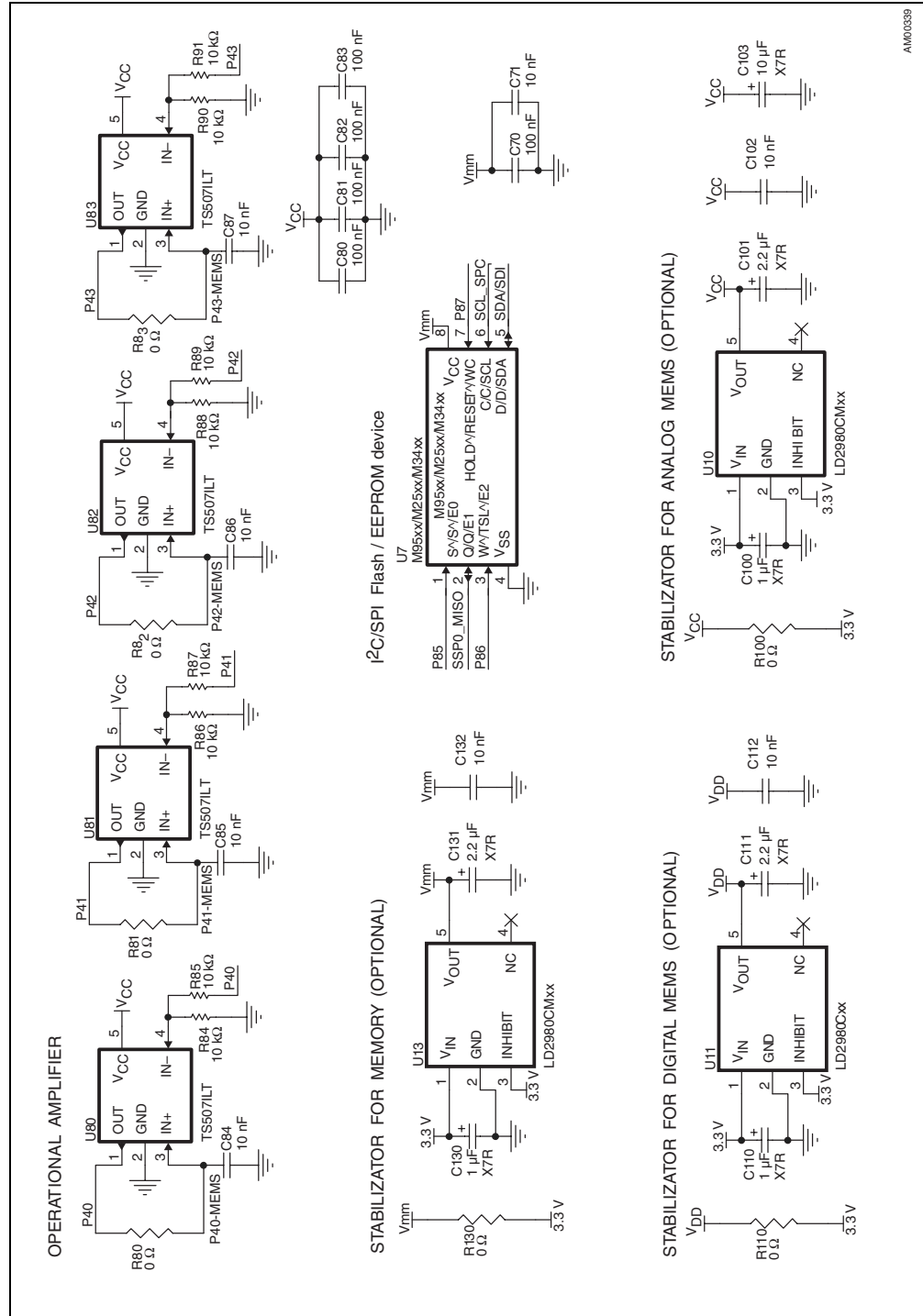

AM00359

## 4 MEMS footprints

### 4.1 LGA8 package

Figure 5. MEMS footprint (LGA8 package)

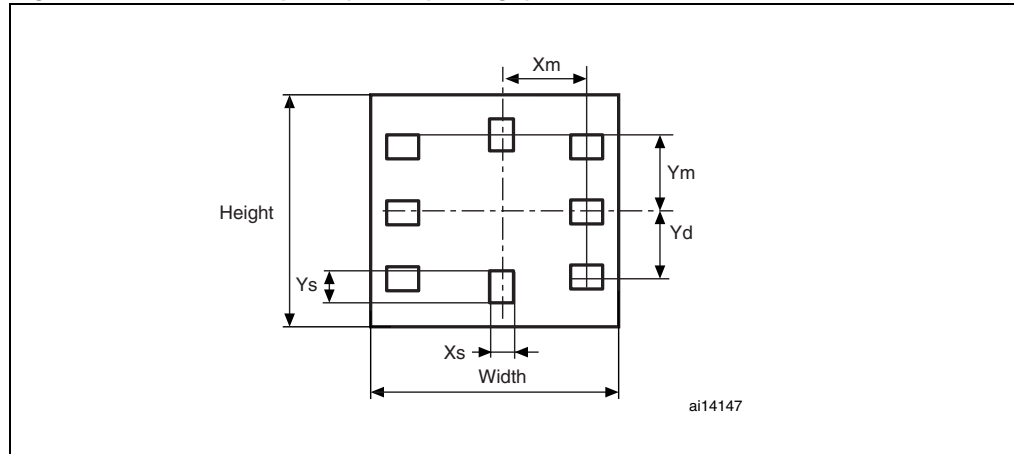

Table 1. Mechanical data (LGA8 package)

Symbol	Dimension	Unit
Xs	0.79	mm
Ys	1.35	mm
Xm	1.81	mm
Ym	1.81	mm
Yd	1.27	mm
Height	5.0	mm
Width	5.0	mm



## 4.2 LGA14 package

Figure 6. MEMS footprint (LGA14 package)

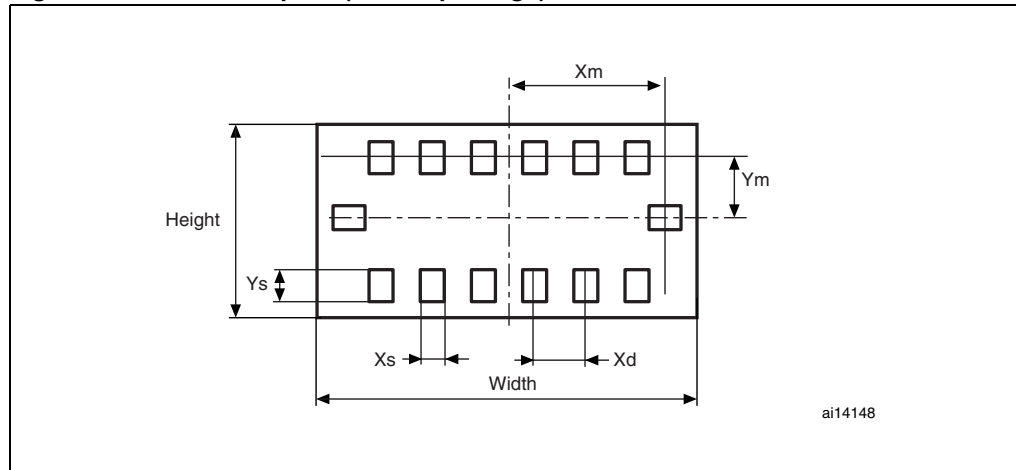

Table 2. Mechanical data (LGA14 package)

Symbol	Dimension	Unit
Xs	0.64	mm
Ys	0.975	mm
Xm	2.0	mm
Ym	1.0	mm
Xd	0.8	mm
Height	3.0	mm
Width	5.0	mm

### 4.3 LGA16 (D) package

Figure 7. MEMS footprint (LGA16 (D) package)

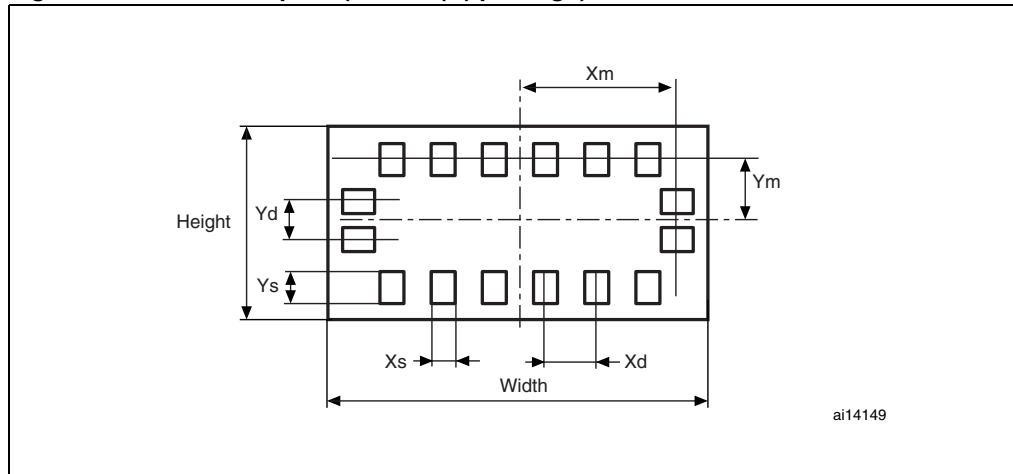

Table 3. Mechanical data (LGA16 (D) package)

Symbol	Dimension	Unit
Xs	0.65	mm
Ys	0.975	mm
Xm	3.25	mm
Ym	1.7	mm
Xd	1.0	mm
Yd	1.0	mm
Height	4.4	mm
Width	7.5	mm

## 4.4 LGA16 (A) package

Figure 8. MEMS footprint (LAG16 (A) package)

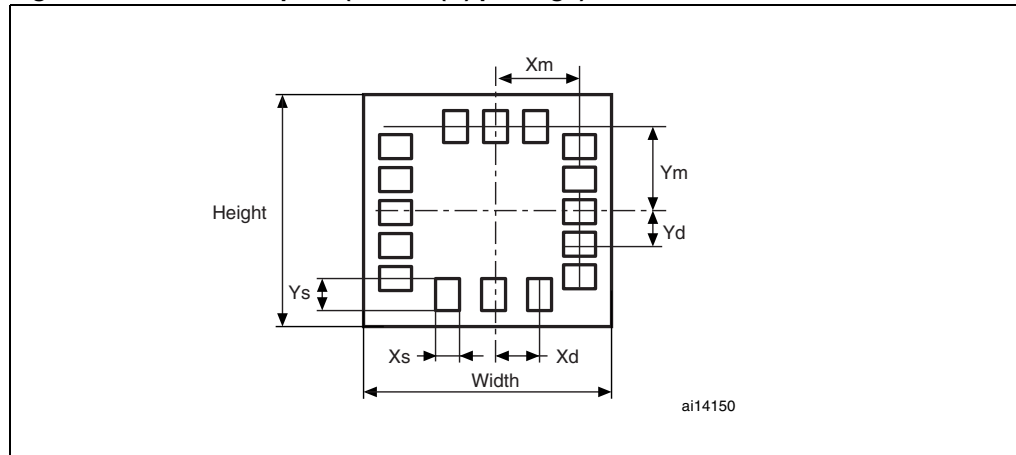
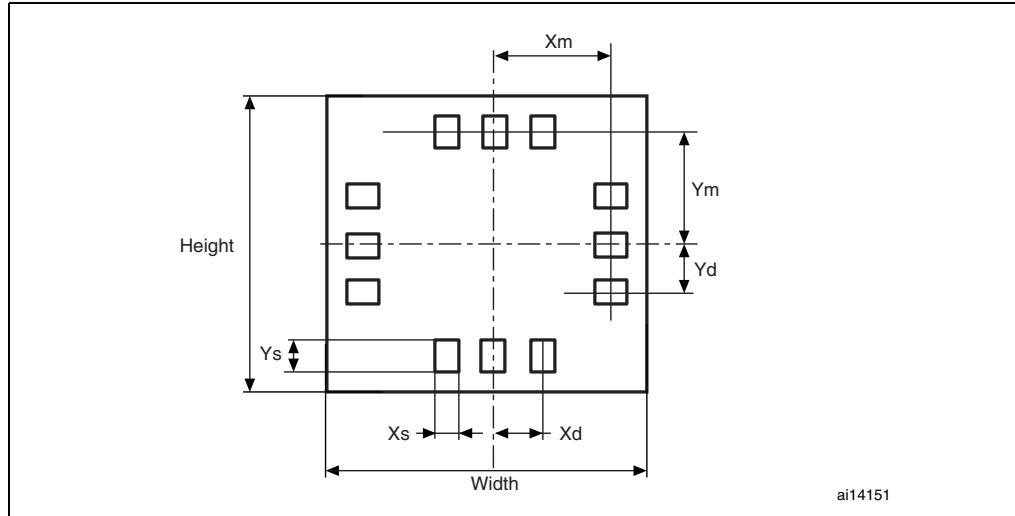

Table 4. Mechanical data (LAG16 (A) package)

Symbol	Dimension	Unit
Xs	0.64	mm
Ys	0.975	mm
Xm	2	mm
Ym	2	mm
Xd	0.8	mm
Yd	0.8	mm
Height	5.0	mm
Width	5.0	mm

## 4.5 QFN28 package

Figure 9. MEMS footprint (QFN28 package)<sup>(1)</sup>



1. Draft only. Not all the 28 pins are shown.

Table 5. Mechanical data (QFN28 package)

Symbol	Dimension	Unit
Xs	0.5	mm
Ys	0.725	mm
Xm	3.225	mm
Ym	3.225	mm
Xd	0.8	mm
Yd	0.8	mm
Height	7.0	mm
Width	7.0	mm

## 5 PCB layout

Figure 10. Top view

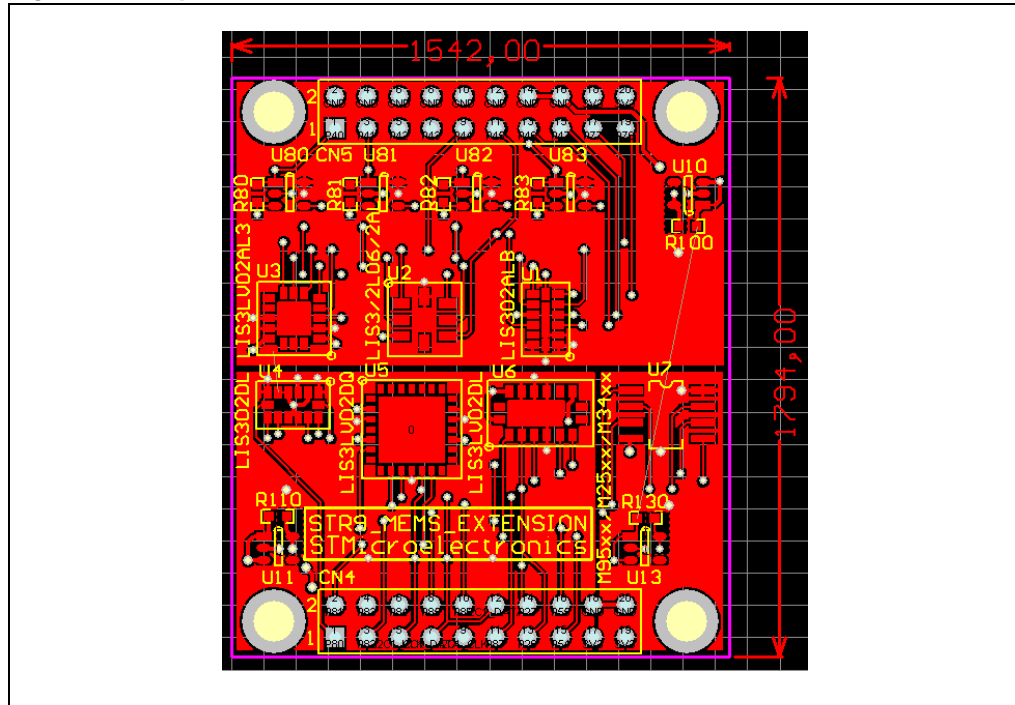
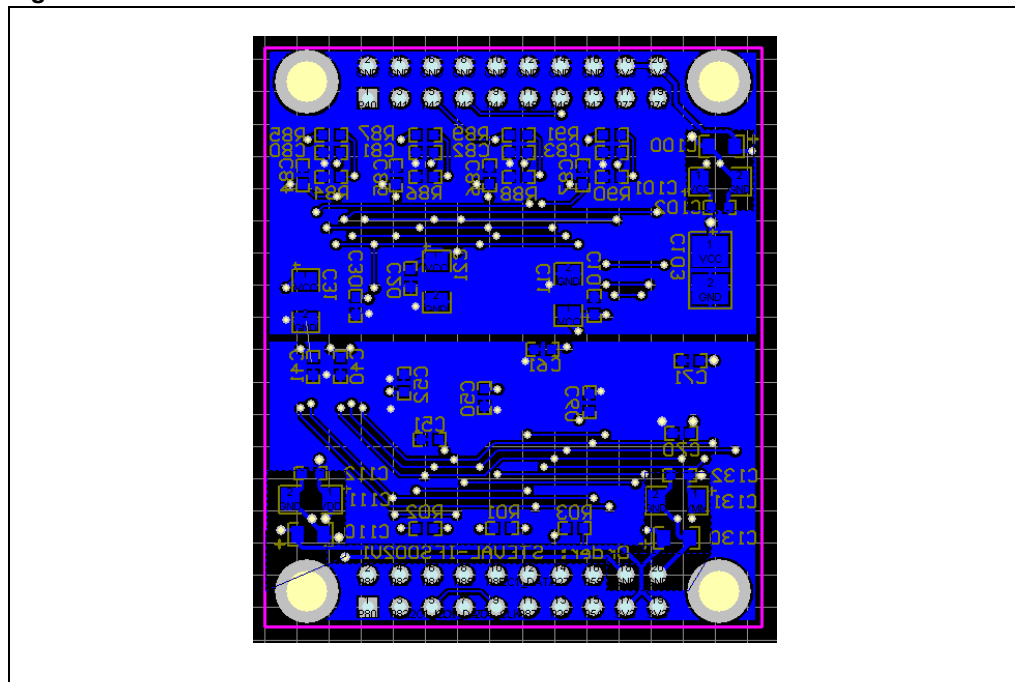

Figure 11. Bottom view



## 6 Bill of materials and assembly instructions

[Table 6](#) to [Table 15](#) show the bill of materials, while sections [Section 6.1](#) to [Section 6.3](#) provide additional information on assembly.

### 6.1 Assembly information for analog MEMS

1. When U10 LD2980CMxx is not assembled use R100 instead. For low voltage MEMS use a voltage regulator. The maximum supply current is around 1.5 mA per device.
2. Operational amplifiers are optional.
  - a) If they are not necessary, use resistors R80, R81, R82, R83 instead.
  - b) If they are required, use operational amplifiers with the following resistor configuration.  
R80, R81, R82, R83 - not assembled  
R84, R86, R88, R90 - not assembled  
R85, R87, R89, R91 - assembled with 0R.
  - c) To alter the gain of the operational amplifiers, use following resistor configuration.  
R80, R81, R82, R83 - not assembled  
The gain is determined by configuration of R84, R86, R88, R90 and R85, R87, R89, R91.
  - d) In all cases it is recommended to have assembled filtering capacitors C84, C85, C86, C87. Default is 10 nF, but this can be changed according to the required filtering features.
3. Only ONE analog MEMS can be assembled. MEMS analog output pins are shared.

### 6.2 Assembly information for digital MEMS

1. When U11 LD2980CMxx is not assembled, use R110 instead. For low voltage MEMS use a voltage regulator. Maximum supply current is around 1.5 mA per device.
2. Both I<sup>2</sup>C and SPI are wired.
  - a) The unused interface must be selected as floating input or third state.
  - b) When using I<sup>2</sup>C, it is recommended to have assembled resistors R01 and R02 which are 4.7 kΩ pull-ups.
  - c) When using SPI, each device has its own chip select.
3. The board is designed to have one MEMS assembled on the board although I<sup>2</sup>C and SPI allows more devices to be used simultaneously. Care should be taken, however with the RDY/INT pins, as they are shared.

### 6.3 Assembly information for serial memory

- When U13 LD2980CMxx is not assembled, use R130 instead. All mentioned memories should be able to operate on 3.3 V. Use a voltage regulator for low voltage memories.
- U7 supports the following series of STMicroelectronics™ memories:
  - M95xx - Serial SPI Bus EEPROM
  - M25xx - Serial SPI Bus Flash memory
  - M34xx - Serial I<sup>2</sup>C Bus EEPROM

**Table 6. Voltage regulator for analog MEMS<sup>(1)</sup>**

Label	Comment	Footprint	Description	Assembled	Order code
U10	LD2980CMxx	SOT23-5L	Voltage regulator	No	ST: LD2980CMxx
R100	0 Ω	0603	Resistor	Yes	GM®: R0603-0R
C100	1 μF	0805	Pol. capacitor	No	Farnell: 422-7086 (X7R)
C101	2.2 μF	1206	Pol. capacitor	No	Farnell: 422-7323 (X7R)
C102	10 nF	0603	Capacitor	No	Farnell: 422-6938 (X7R)
C103	10 μF	3528_AB	Pol. capacitor	Yes	Farnell: 331-3888 B45196H2106K109

- By default, the voltage regulator is not assembled.

**Table 7. Voltage regulator for digital MEMS<sup>(1)</sup>**

Label	Comment	Footprint	Description	Assembled	Order code
U11	LD2980Cxx	SOT23-5L	Voltage regulator	No	ST: LD2980Cxx
R110	0 Ω	0603	Resistor	Yes	GM: R0603-0R
C110	1 μF	0805	Pol. capacitor	No	Farnell: 422-7086 (X7R)
C111	2.2 μF	1206	Pol. capacitor	No	Farnell: 422-7323 (X7R)
C112	10 μF	0603	Capacitor	No	Farnell: 422-6938 (X7R)

- By default, the voltage regulator is not assembled.

**Table 8. Voltage regulator for memory<sup>(1)</sup>**

Label	Comment	Footprint	Description	Assembled	Order code
U13	LD2980CMxx	SOT23-5L	Voltage regulator	No	ST: LD2980CMxx
R130	0 Ω	0603	Resistor	Yes	GM: R0603-0R
C130	1 μF	0805	Pol. capacitor	No	Farnell: 422-7086 (X7R)
C131	2.2 μF	1206	Pol. capacitor	No	Farnell: 422-7323 (X7R)
C132	10 nF	0603	Capacitor	No	Farnell: 422-6938 (X7R)

- By default, the voltage regulator is not assembled.

**Table 9. Analog MEMS<sup>(1)</sup>**

Label	Comment	Footprint	Description	Assembled	Order code
CN5	ANALOG_CON	HDR2X10STD	Header 10X2	Yes	GM: S2G20
U1	LIS302ALB	LGA14AD	Analog MEMS	No	ST: LIS302ALB
C10	100 nF	0603	Capacitor	No	Farnell: 422-6859 (X7R)
C11	2.2 $\mu$ F	1206	Pol. capacitor	No	Farnell: 422-7323 (X7R)
U2	LIS3/2L06/2AL	LGA8A	Analog MEMS	No	ST: LIS3/2L06/2AL (LIS3L06AL for MP)
C20	100 nF	0603	Capacitor	No	Farnell: 422-6859 (X7R)
C21	2.2 $\mu$ F	1206	Pol. capacitor	No	Farnell: 422-7323 (X7R)
U3	LIS3LV02AL3	LGA16A	Analog MEMS	No	ST: LIS3LV02AL3
C30	100 nF	0603	Capacitor	No	Farnell: 422-6859 (X7R)
C31	2.2 $\mu$ F	1206	Pol. capacitor	No	Farnell: 422-7323 (X7R)

1. By default, the LIS3/2L06/2AL is assembled.

**Table 10. Digital MEMS<sup>(1),(2)</sup>**

Label	Comment	Footprint	Description	Assembled	Order code
CN4	DIGITAL_CON	HDR2X10STD	Header 10X2	Yes	GM: BL220G
U4	LIS302DL	LGA14AD	Digital MEMS	Yes	ST: LIS302DL
C40	100 nF	0603	Capacitor	Yes	Farnell: 422-6859 (X7R)
C41	100 nF	0603	Capacitor	Yes	Farnell: 422-6859 (X7R)
U5	LIS3LV02DQ	QFN28D	Digital MEMS	No	ST: LIS3LV02DQ
C50	100 nF	0603	Capacitor	No	Farnell: 422-6859 (X7R)
C51	100 nF	0603	Capacitor	No	Farnell: 422-6859 (X7R)
U6	LIS3LV02DL	LGA16D	Digital MEMS	No	ST: LIS3LV02DL
C60	100 nF	0603	Capacitor	No	Farnell: 422-6859 (X7R)
C61	100 nF	0603	Capacitor	No	Farnell: 422-6859 (X7R)
R01	4.7 k $\Omega$	0603	Resistor	Yes (I <sup>2</sup> C)	GM: R0603-4k7
R02	4.7 k $\Omega$	0603	Resistor	Yes (I <sup>2</sup> C)	GM: R0603-4k7
R03	4.7 k $\Omega$	0603	Resistor	Yes (SPI)	GM: R0603-4k7

1. By default, the I<sup>2</sup>C interface is used.

2. By default, the LIS3LV02DL is assembled.



**Table 11. Memory<sup>(1)</sup>**

Label	Comment	Footprint	Description	Assembled	Order code
U7	M95xx/M25xx/ M34xx	SO8	Serial Flash/EEPROM	No	ST: M95xx/M25xx/M34xx
C70	10 nF	0603	Capacitor	No	Farnell: 422-6859 (X7R)
C71	10 nF	0603	Capacitor	No	Farnell: 422-6938 (X7R)

1. By default, the memory is not assembled.

**Table 12. Operational amplifier X-axis for analog MEMS<sup>(1)</sup>**

Label	Comment	Footprint	Description	Assembled	Order code
U80	TS507ILT	SOT23-5L	Operational amplifier	No	ST: TS507ILT
R80	0 $\Omega$	0603	Resistor	Yes	GM: R0603-0R
R84	10 k $\Omega$	0603	Resistor	No	GM: R0603-10k
R85	10 k $\Omega$	0603	Resistor	No	GM: R0603-10k
C80	100 nF	0603	Capacitor	No	Farnell: 422-6859 (X7R)
C84	10 nF	0603	Capacitor	No	Farnell: 422-6938 (X7R)

1. By default, the amplifier is not assembled.

**Table 13. Operational amplifier Y-axis for analog MEMS<sup>(1)</sup>**

Label	Comment	Footprint	Description	Assembled	Order code
U81	TS507ILT	SOT23-5L	Operational amplifier	No	ST: TS507ILT
R81	0 $\Omega$	0603	Resistor	Yes	GM: R0603-0R
R86	10 k $\Omega$	0603	Resistor	No	GM: R0603-10k
R87	10 k $\Omega$	0603	Resistor	No	GM: R0603-10k
C81	100 nF	0603	Capacitor	No	Farnell: 422-6859 (X7R)
C85	10 nF	0603	Capacitor	No	Farnell: 422-6938 (X7R)

1. By default, the amplifier is not assembled.

**Table 14. Operational amplifier Z-axis for analog MEMS<sup>(1)</sup>**

Label	Comment	Footprint	Description	Assembled	Order code
U82	TS507ILT	SOT23-5L	Operational amplifier	No	ST: TS507ILT
R82	0 $\Omega$	0603	Resistor	Yes	GM: R0603-0R
R88	10 k $\Omega$	0603	Resistor	No	GM: R0603-10k
R89	10 k $\Omega$	0603	Resistor	No	GM: R0603-10k
C82	100 nF	0603	Capacitor	No	Farnell: 422-6859 (X7R)
C86	10 nF	0603	Capacitor	No	Farnell: 422-6938 (X7R)

1. By default, the amplifier is not assembled.

**Table 15. Operational amplifier XYZ-axes for analog MEMS<sup>(1)</sup>**

Label	Comment	Footprint	Description	Assembled	Order code
U83	TS507ILT	SOT23-5L	Operational amplifier	No	ST: TS507ILT
R83	0 $\Omega$	0603	Resistor	Yes	GM: R0603-0R
R90	10 k $\Omega$	0603	Resistor	No	GM: R0603-10k
R91	10 k $\Omega$	0603	Resistor	No	GM: R0603-10k
C83	100 nF	0603	Capacitor	No	Farnell: 422-6859 (X7R)
C87	10 nF	0603	Capacitor	No	Farnell: 422-6938 (X7R)

1. By default, the amplifier is not assembled.

## 7 Revision history

Table 16. Document revision history

Date	Revision	Changes
21-Apr-2008	1	Initial release.
17-Oct-2008	2	Updated <a href="#">Figure 1</a> , <a href="#">Figure 2</a> , <a href="#">Figure 3</a> and added <a href="#">Figure 4</a> (reformatted previous <a href="#">Figure 3</a> into <a href="#">Figure 3</a> and <a href="#">Figure 4</a> ), updated (reformatted) <a href="#">Table 6</a> to <a href="#">Table 15</a> .
05-Mar-2009	3	Renamed “extension board” to demonstration board”, updated <a href="#">Section 2</a> , renamed title of <a href="#">Figure 2</a> and <a href="#">Section 3</a> , <a href="#">Table 1</a> to <a href="#">Table 5</a> and <a href="#">Table 15</a> , updated <a href="#">Figure 3</a> and <a href="#">Figure 4</a> , <a href="#">Table 6</a> and <a href="#">Table 9</a> .

**Please Read Carefully:**

Information in this document is provided solely in connection with ST products. STMicroelectronics NV and its subsidiaries ("ST") reserve the right to make changes, corrections, modifications or improvements, to this document, and the products and services described herein at any time, without notice.

All ST products are sold pursuant to ST's terms and conditions of sale.

Purchasers are solely responsible for the choice, selection and use of the ST products and services described herein, and ST assumes no liability whatsoever relating to the choice, selection or use of the ST products and services described herein.

No license, express or implied, by estoppel or otherwise, to any intellectual property rights is granted under this document. If any part of this document refers to any third party products or services it shall not be deemed a license grant by ST for the use of such third party products or services, or any intellectual property contained therein or considered as a warranty covering the use in any manner whatsoever of such third party products or services or any intellectual property contained therein.

**UNLESS OTHERWISE SET FORTH IN ST'S TERMS AND CONDITIONS OF SALE ST DISCLAIMS ANY EXPRESS OR IMPLIED WARRANTY WITH RESPECT TO THE USE AND/OR SALE OF ST PRODUCTS INCLUDING WITHOUT LIMITATION IMPLIED WARRANTIES OF MERCHANTABILITY, FITNESS FOR A PARTICULAR PURPOSE (AND THEIR EQUIVALENTS UNDER THE LAWS OF ANY JURISDICTION), OR INFRINGEMENT OF ANY PATENT, COPYRIGHT OR OTHER INTELLECTUAL PROPERTY RIGHT.**

**UNLESS EXPRESSLY APPROVED IN WRITING BY AN AUTHORIZED ST REPRESENTATIVE, ST PRODUCTS ARE NOT RECOMMENDED, AUTHORIZED OR WARRANTED FOR USE IN MILITARY, AIR CRAFT, SPACE, LIFE SAVING, OR LIFE SUSTAINING APPLICATIONS, NOR IN PRODUCTS OR SYSTEMS WHERE FAILURE OR MALFUNCTION MAY RESULT IN PERSONAL INJURY, DEATH, OR SEVERE PROPERTY OR ENVIRONMENTAL DAMAGE. ST PRODUCTS WHICH ARE NOT SPECIFIED AS "AUTOMOTIVE GRADE" MAY ONLY BE USED IN AUTOMOTIVE APPLICATIONS AT USER'S OWN RISK.**

Resale of ST products with provisions different from the statements and/or technical features set forth in this document shall immediately void any warranty granted by ST for the ST product or service described herein and shall not create or extend in any manner whatsoever, any liability of ST.

ST and the ST logo are trademarks or registered trademarks of ST in various countries.

Information in this document supersedes and replaces all information previously supplied.

The ST logo is a registered trademark of STMicroelectronics. All other names are the property of their respective owners.

© 2009 STMicroelectronics - All rights reserved

STMicroelectronics group of companies

Australia - Belgium - Brazil - Canada - China - Czech Republic - Finland - France - Germany - Hong Kong - India - Israel - Italy - Japan - Malaysia - Malta - Morocco - Singapore - Spain - Sweden - Switzerland - United Kingdom - United States of America

[www.st.com](http://www.st.com)