

# E102 EVALUATION BOARD USER GUIDE

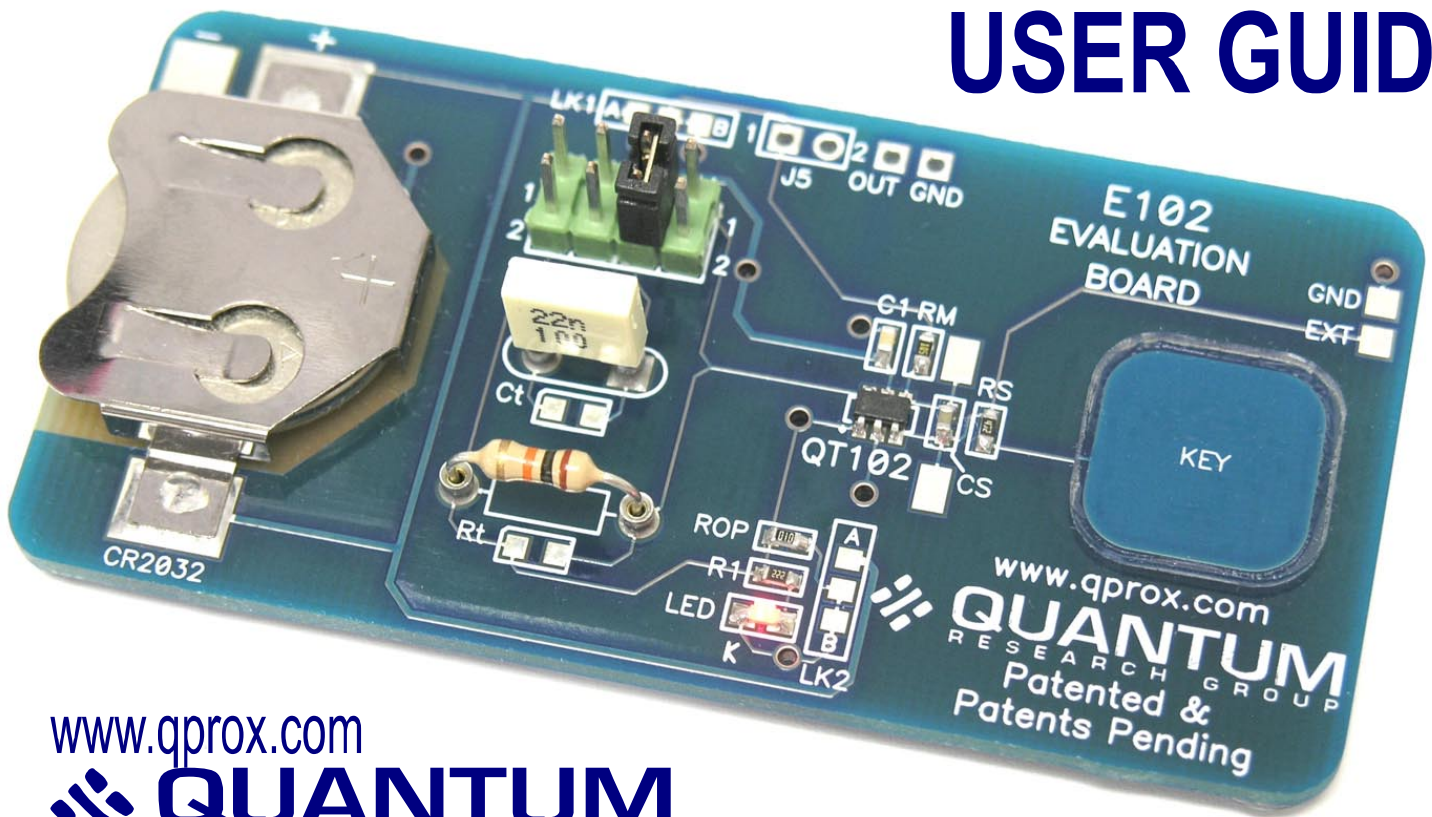

[www.qprox.com](http://www.qprox.com)  
**QUANTUM**  
RESEARCH GROUP

## Using the E102:

This kit is designed for the evaluation and development of applications using the QT102-ISG Integrated Circuit (IC).

***Refer to the QT102-ISG datasheet for details (see [www.qprox.com/downloads](http://www.qprox.com/downloads)).***

- Insert the battery provided into the battery holder on the E102 board. Ensure that the battery has the correct orientation (negative (-) side to board) or the E102 will not work.
- Touch KEY and the LED will light. After the Auto-off Delay is reached (actual time is dependent on Voltage level, Ct and Rt tolerances), the LED will switch off.

**Default setting:** User-set Auto-Off Delay (J3 Pins 1 & 2) of 87 seconds. (Ct = 22nF, Rt = 10 kΩ)

**Note:** LED will light when KEY is touched if the QT102 is set to Active High Output. If QT102 is changed to give Active Low Output, then the LED will light until KEY touched.

An external power supply can be used instead of a battery.

**WARNING:** if an external power supply is used then the battery **MUST** be removed.

# Schematic:

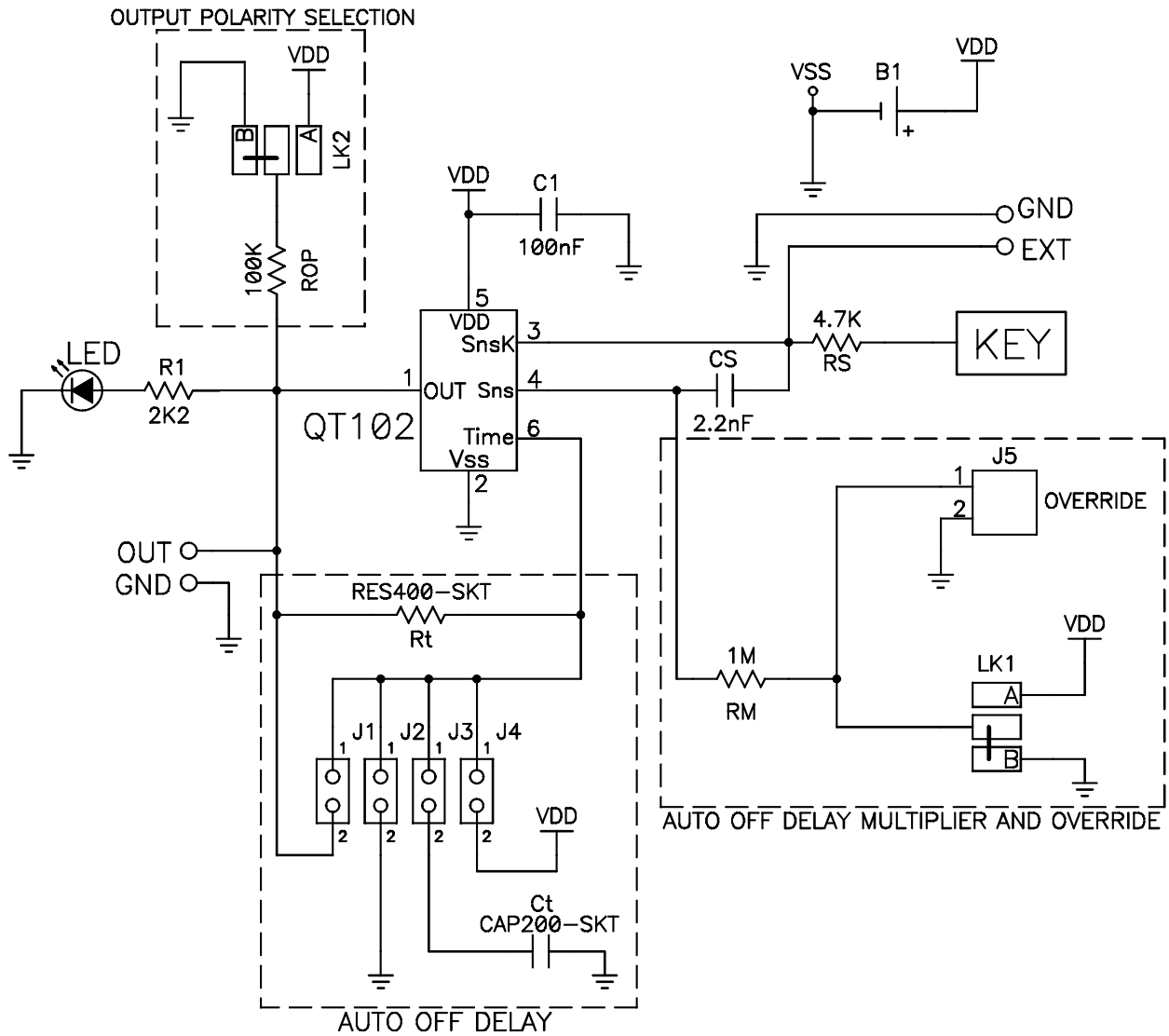

## Configuring the E102:

The Auto-Off Delay and Output Polarity can be set using the table below:

Jumper Position (Pins 1-2)	Auto-Off Delay			
J1	60 Minutes	60 Minutes	24 Hours	24 Hours
J2	Infinite	15 Minutes	Infinite	6 Hours
J3	User (Ct,Rt)	User (Ct,Rt)	User (Ct,Rt)	User (Ct,Rt)
J4	15 Minutes	Infinite	6 Hours	Infinite

<b>Multiplier: (LK1)</b>	x1: (VSS)	x1: (VSS)	x24: (VDD)	x24: (VDD)
<b>Output: (LK2)</b>	Active High: (VSS)	Active Low: (VDD)	Active High: (VSS)	Active Low: (VDD)

The E102 can be used to connect a User electrode to the QT102 (using EXT and GND pads: The value of Cs may require changing. Large pads either side of Cs are available for fitting leaded capacitors in parallel). The E102 can also connect to a User output (using OUT and GND pads).

The Auto-Off Delay can be extended or the QT102 output can be switched off immediately by pulsing the voltage on the delay multiplier resistor RM through J5.

**(Refer to QT102 Datasheet for further details)**

## User-Programmed Auto-Off Delay:

By changing the values of  $C_t$  and  $R_t$ , the Auto-Off Delay can be changed. See chart for examples:

QT102 Active High output, VDD = 3V, (x1 Multiplier)

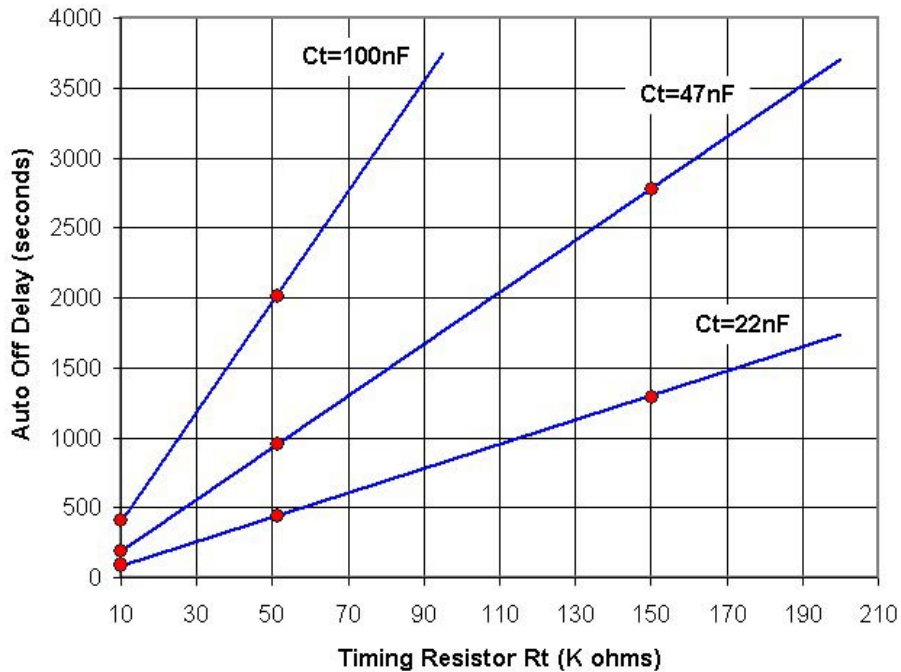

*The values highlighted on the chart can be achieved using supplied kit components.*

## Troubleshooting:

Problem	Potential Solution
<b>E102 does not work</b>	If using a battery, check that the negative (-) side is facing the board. Check/replace battery, check connections. If using an external power supply, check that the correct connections have been made. <i>(Ensure the battery has been removed)</i>
<b>Inaccurate timeout values</b>	Rt/Ct/voltage tolerance dependent. Measure the actual values
<b>Unexpected timeout delay</b>	Ensure that the J1, J2, J3 or J4 is set correctly.
<b>Timeout delay not x1 or x24, as expected</b>	Check LK1 setting.
<b>LED unexpectedly on</b>	Check LK2 setting.

## E102 Kit Contents:

<b>1x E102 Evaluation Board</b>			
<b>1x CR2032 Battery, 3V, 235mAh</b>			
<b>2x sample QT102-ISG ICs</b>			
<b>1x E102 User Guide</b>			
<b>Example Ct (47nF, 100nF) &amp; Rt (51kΩ, 150kΩ) Components</b>			
<i>Packed by:</i>		<i>Dated:</i>	

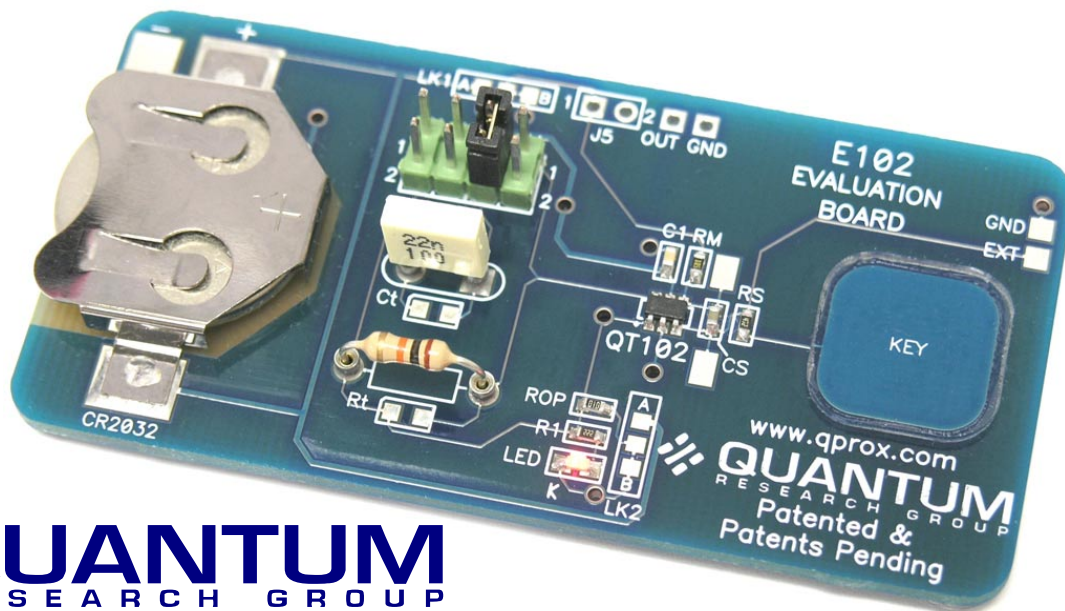

Corporate Headquarters:  
 1 Mitchell Point  
 Ensign Way, Hamble  
 Southampton SO31 4RF  
 United Kingdom  
 Tel:+44 (0)23 8056 5600  
 Fax:+44 (0)23 8045 3939

North America:  
 651 Holiday Drive Bldg 5/300  
 Pittsburgh, PA 15220  
 USA  
 Tel:412-391-7367  
 Fax:412-291-1015

Developer: Kevin Snoad  
 Copyright © 2007 QRG Ltd.  
 All rights reserved  
 Patented and patents pending  
 www.qprox.com  
 REV 101.0907