

Development Kit
MLX91205 / CSA-1V
REV003

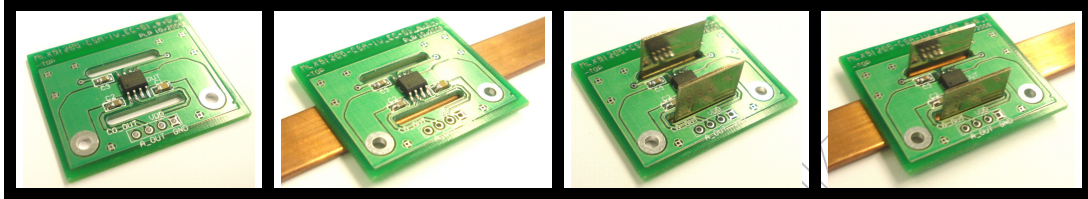

1 Description

The development kit provides the needed information and components to evaluate the current sensors MLX91205 and/or CSA-1V. The main goal is to show the functionalities and the features of the parts in a simple and effective way, without the need of investing precious time and money for develop design.

The kit includes:

- 1 MLX91205LB mounted on PCB_EC01
- 1 MLX91205LB mounted on PCB_EC02
- 1 separate MLX91205LB
- 3 separate MLX91205HBs
- 1 separate PCB_EC01
- 1 separate PCB_EC02
- 2 shields U_12

The kit does not include a busbar.

Datasheet and Application Note can be found on www.melexis.com

2 Specification of EC-01

The included PCB utilizes PCB traces for medium current range measurements. This arrangement was created for continuous currents up to ± 30 A RMS, but can handle, without damage, short current peaks up to ± 50 A. The typical sensitivity obtained with this design with and without the use of a magnetic shield is shown on the last page in the typical Output diagram.

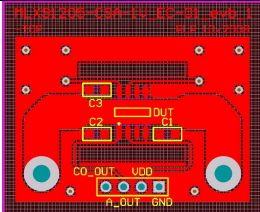
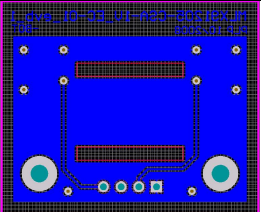
Layer:	Two layer with copper thickness 105 μ m The top layer is a conductor The bottom layer is an expanded ground layer	
	TOP- layer	Bottom- layer
		
Current:	We recommend: MAX 30A RMS for PCB application MAX 1kA for Busbar application	
Dimension [l/b/h]:	36.8mm x 30.5mm x 1.6mm	

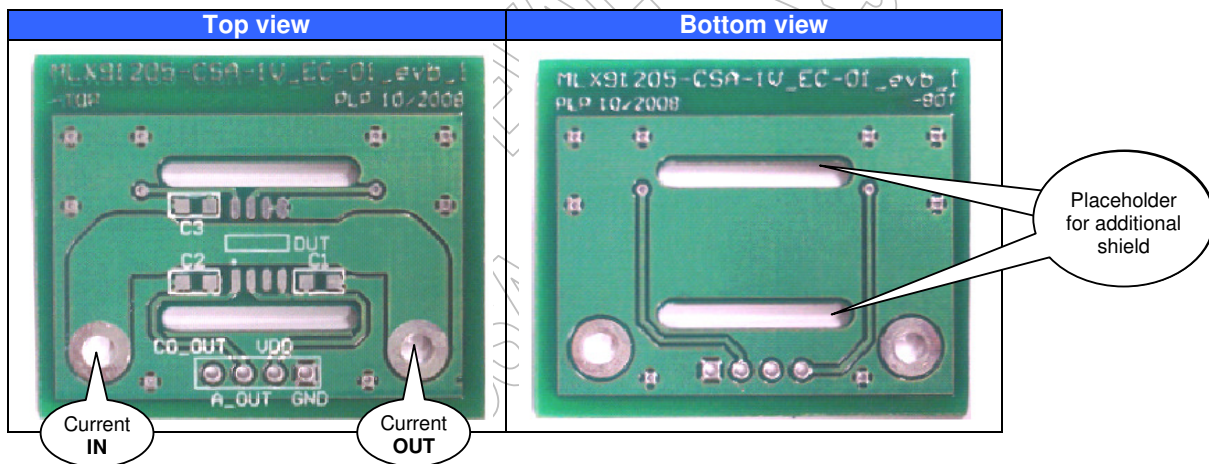

3 Specification of EC-02

The included PCB utilizes PCB loops for small current range measurements. This arrangement was created for continuous currents up to ± 30 A RMS, but can handle, without damage, short current peaks up to ± 50 A. The typical sensitivity obtained with this design with and without the use of a magnetic shield is shown on the last page in the typical Output diagram.

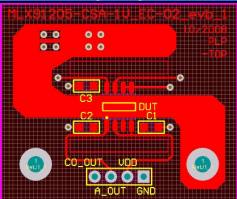
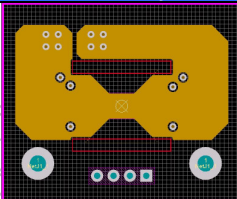
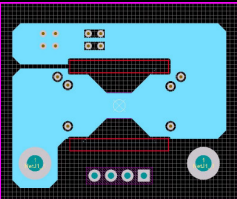
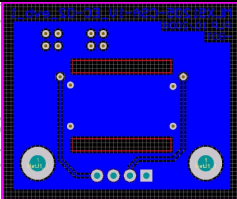
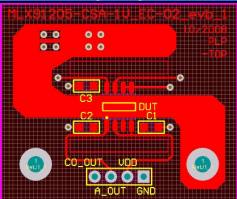
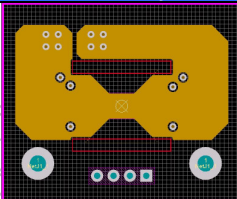
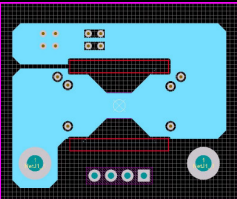
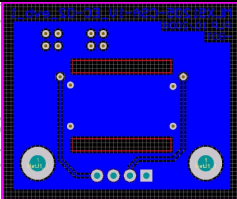
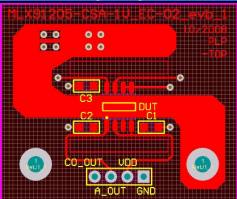
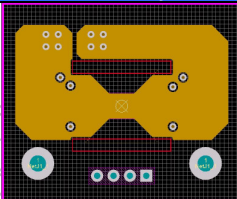
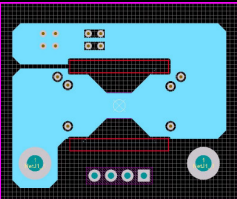
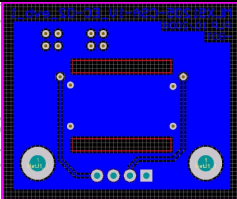
Layer:	Four layers, Top- and Bottom- layer with copper thickness 105 μ m, Second- and the Third- layer with copper thickness 35 μ m Three loops are on the PCB								
	<table border="1"> <tr> <th>Top- layer</th> <th>Second- layer</th> </tr> <tr> <td></td> <td></td> </tr> <tr> <th>Third - layer</th> <th>Bottom- layer</th> </tr> <tr> <td></td> <td></td> </tr> </table>	Top- layer	Second- layer			Third - layer	Bottom- layer		
Top- layer	Second- layer								
									
Third - layer	Bottom- layer								
									
Current:	We recommend: MAX 30A RMS for PCB application MAX 1kA for Busbar application								
Dimension [l/b/h]:	36.8mm x 30.5mm x 2mm								

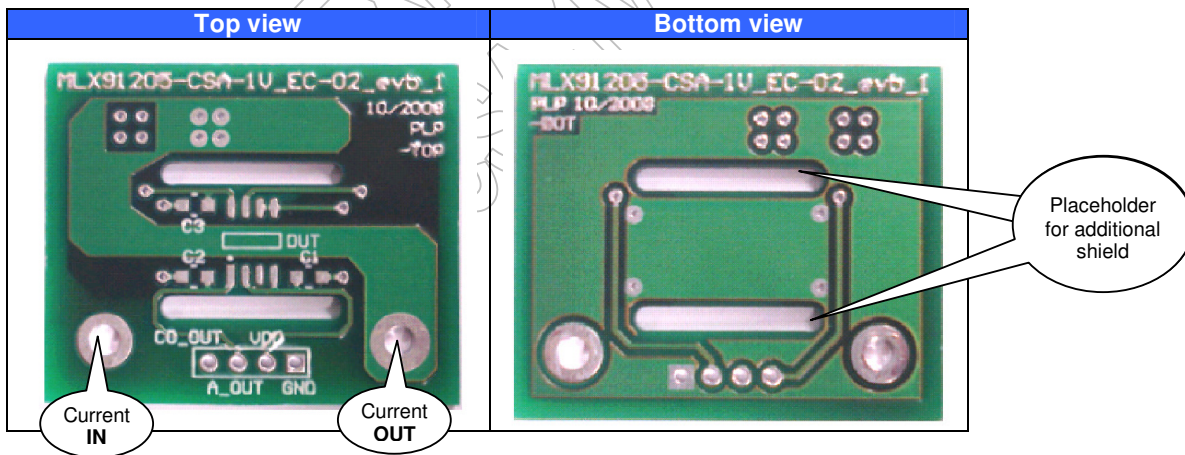

4 Settings

4.1 Schematic

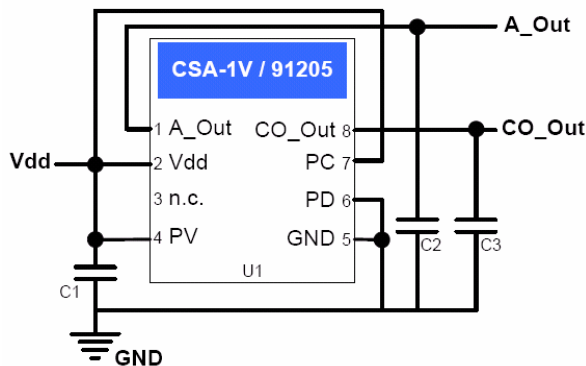

U1/ DUT:	CSA-1V or 91205
C1:	100nF
C2:	1nF
C3:	1nF

VDD:	pos. supply voltage
GND:	supply common
A_OUT:	analog sensor output
C_OUT:	common output

4.2 Measurement

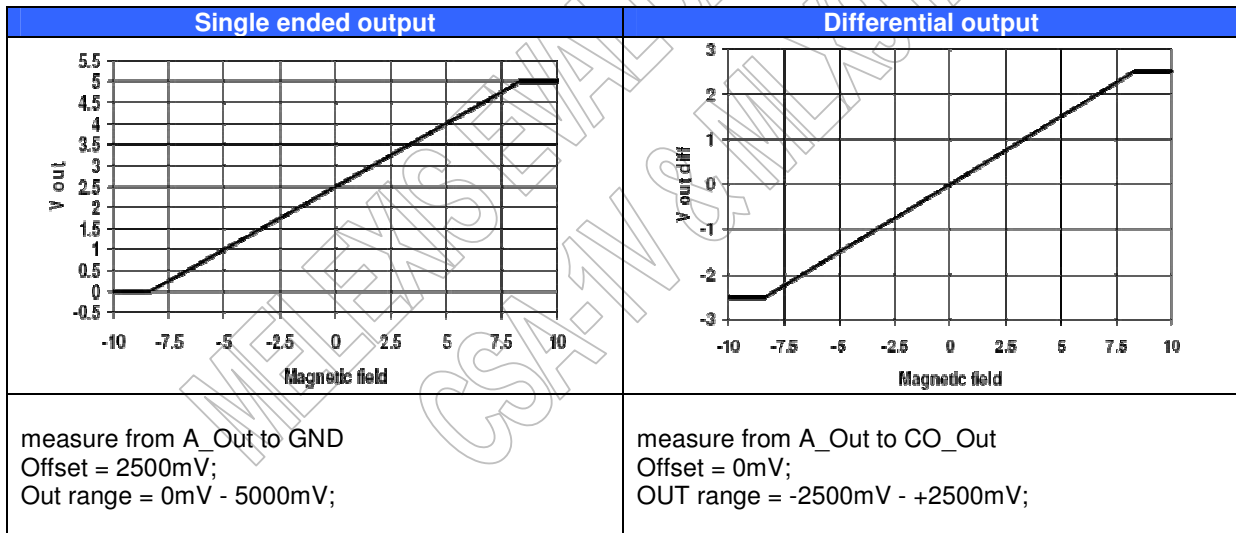

5 Shield description

The shield is made of soft ferromagnetic material with a high μ_r value, this attracts and concentrates the magnetic flux. In order to get a low hysteresis the shields are annealed after shaping. Any applied mechanical stress will deteriorate the performance and should be avoided. The purpose of the shield is to concentrate the wanted signal and to reduce the influence of stray fields. Our shield is usable for busbar and PCB applications.

5.1 Settings

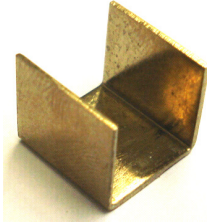
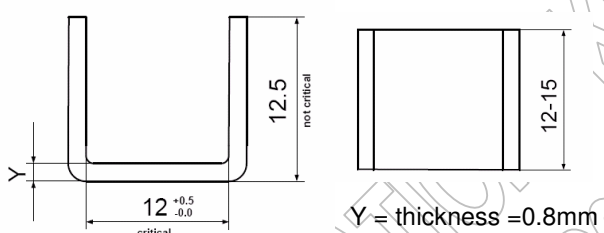
View	Dimension [mm]
	 <p>Y = thickness = 0.8mm</p>

- Material: Mu - Metal with 48%Ni
- Shielding factor is > 50 in the linear range
- Nonlinearity is $< 0.05\text{mT}$ in the linear range
- The onset of the saturation starts at about $\pm 25\text{mT}$
- Weight: 3.14g

5.2 Good to know about shield

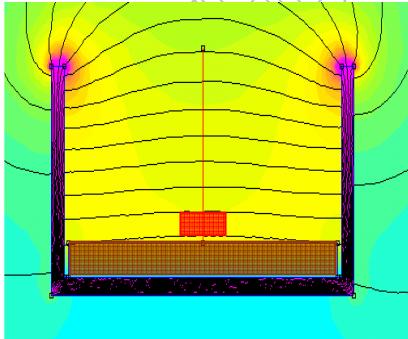
Simulation	Recommendation
	<ul style="list-style-type: none"> • The closer the sensor to the ground plate of the shield, the better the shielding against external stray fields → try to position the sensor as close as possible to the ground plate of the shield • The higher and longer the shield the better the shielding → choose the right dimension for your application • The closer the sensor to the bus bar the better is the signal to noise ratio → try to position the sensor as close as possible to the busbar

6 OUTPUT Measurement

6.1 Sensor programming

Sensor:	91205HB	CSA-1V / 91205LB
Sensitivity:	100V/T	280V/T
Offset:	< 10mV	< 10mV

6.2 OUTPUT Range without Busbar (Typical values)

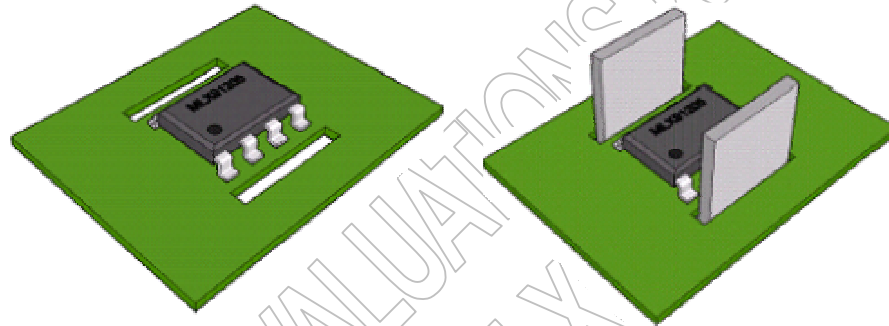

Measured with PCB EC-01

	without shield		with shield	
	91205HB	CSA-1V / 91205LB	91205HB	CSA-1V / 91205LB
Sensitivity [mV/A]:	12	32	18	47
Current range [A]:	+/-200	+/-70	+/-135	+/-50

Measured with PCB EC-02

	without shield		with shield	
	91205HB	CSA-1V / 91205LB	91205HB	CSA-1V / 91205LB
Sensitivity [mV/A]:	26	70	45	125
Current range [A]:	+/-90	+/-30	+/-50	+/-18

6.3 OUTPUT Range with Busbar (Typical values)

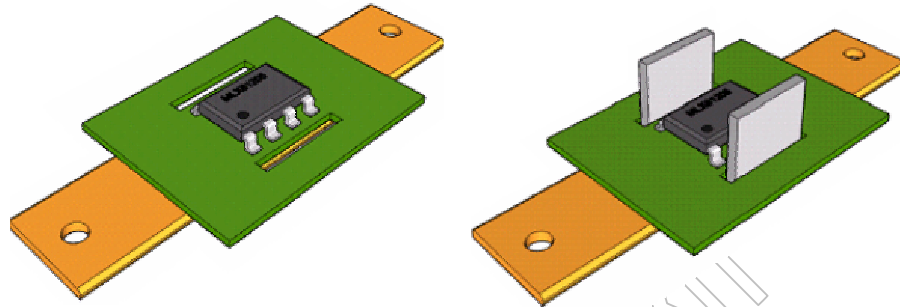

Measured with PCB EC-01 and PCB EC-02

	without shield		with shield	
	91205HB	CSA-1V / 91205LB	91205HB	CSA-1V / 91205LB
Sensitivity [mV/A]:	3	8.5	9.9	28
Current range [A]:	+/-800	+/-285	+/-250	+/-90

- The dimension of the used copper busbar was 12mm x 100mm x 2mm.

MELEXIS EVALUATION KIT
CSA-1V & MLX91205

7 Typical output

- CSA-1V shows a similar typical sensitivity as MLX91205LB

7.1 Typical output with PCB_EC-01

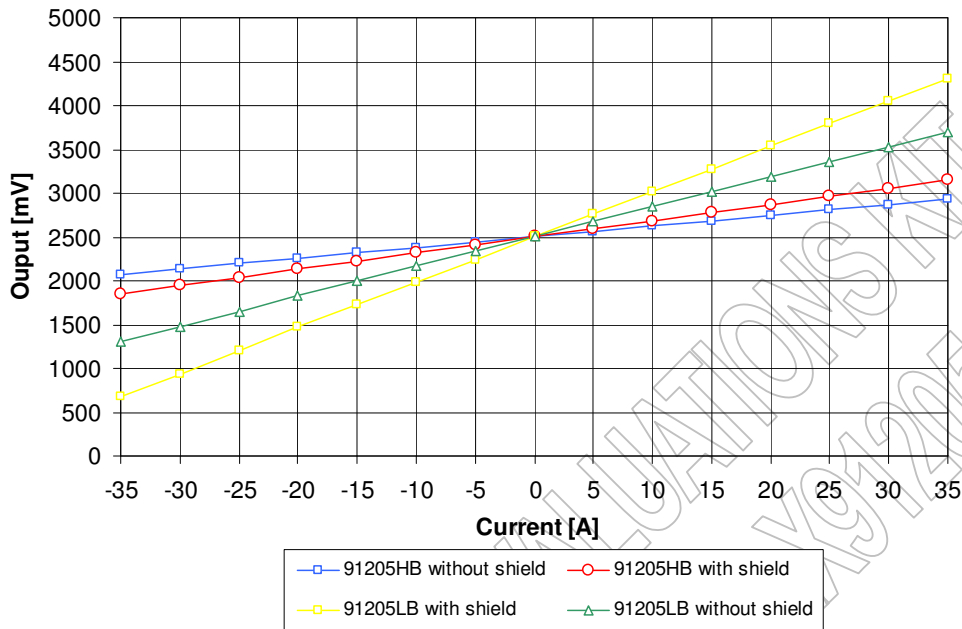

7.2 Typical output PCB_EC-02

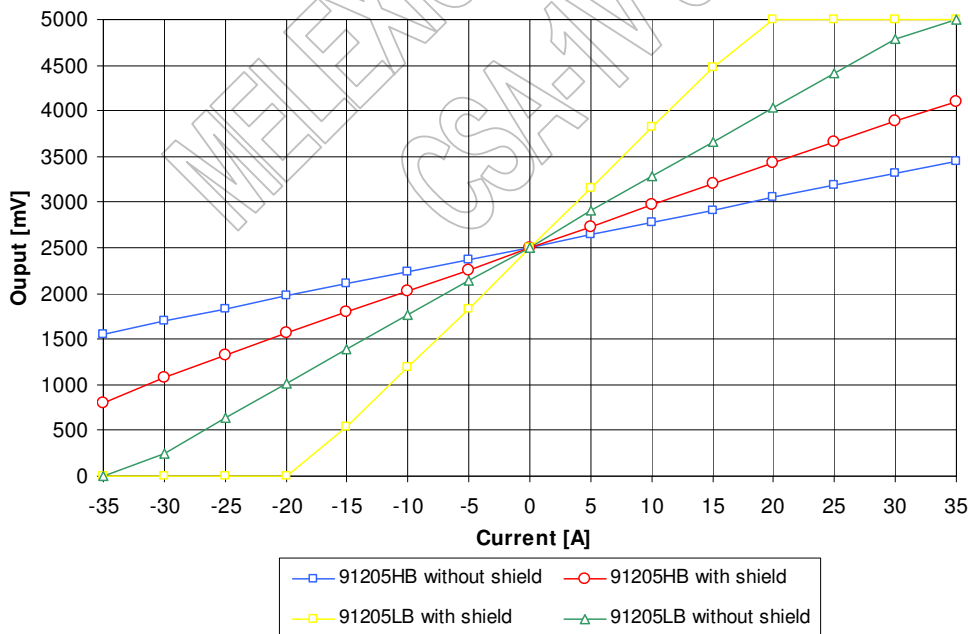

7.3 Typical output with bus bar

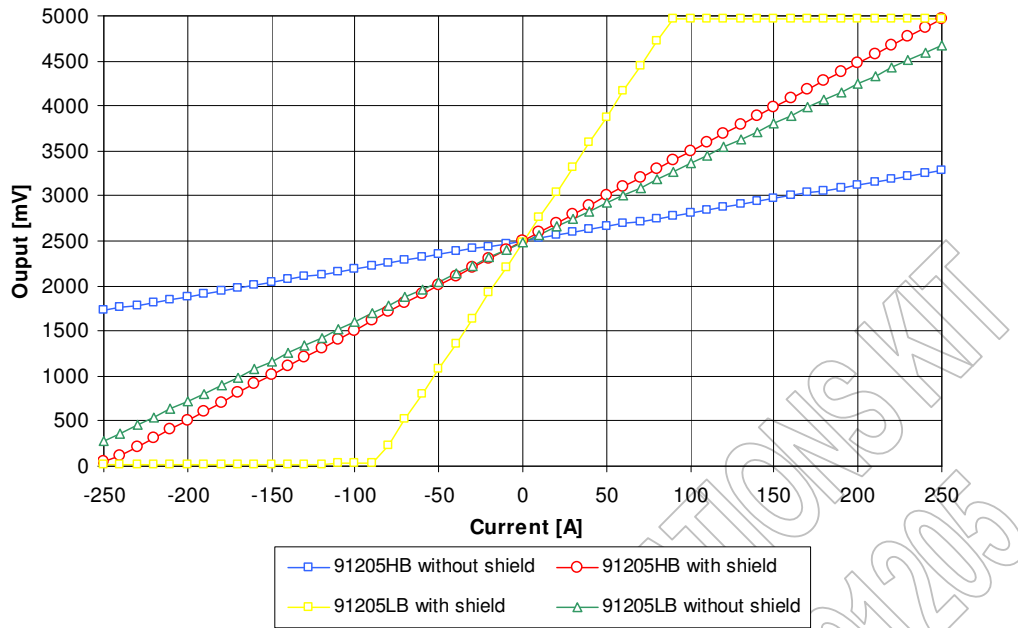

MELEXIS EVALUATION KIT
CSA-1V & MLX91205