

## EVAL-ADXL345Z

### GENERAL DESCRIPTION

The EVAL-ADXL345Z is a simple evaluation board that allows quick evaluation of the performance of the ADXL345 3-axis digital accelerometer. The EVAL-ADXL345Z has two sets of 0.1 inch spaced vias, for population of a 4-pin and 5-pin header, for access to all power and signal lines. The vias or headers allow the evaluation board to be attached to a prototyping board (breadboard) or attached to the PCB in an existing system. Four holes are provided for mechanical attachment of the EVAL-ADXL345Z to the application. An external host processor is required for communication to the part.

The dimensions of the EVAL-ADXL345Z are 20 mm  $\times$  20 mm with mounting holes set 15 mm  $\times$  15 mm at the corners of the printed circuit board (PCB).

### CIRCUIT DESCRIPTION

The schematic of the EVAL-ADXL345Z is shown in Figure 1. See the [ADXL345](#) data sheet for configuration of the accelerometer after it is connected to the application host processor.

The PCB layout of the EVAL-ADXL345Z is shown in Figure 2. The EVAL-ADXL345Z has three factory installed capacitors for bypass: two 100 nF capacitors and a 10  $\mu\text{F}$  capacitor. C1 and C2 are  $V_S$  bypass capacitors to reduce analog supply noise and C3, located between  $V_{DD\ I/O}$  and GND, is provided to reduce digital clocking noise.

### HANDLING CONSIDERATIONS

The EVAL-ADXL345Z is not reverse polarity protected. Reversing the  $V_S$  or  $V_{DD\ I/O}$  supply and GND pins can cause damage to the ADXL345.

Dropping the EVAL-ADXL345Z on a hard surface can generate several thousand  $g$ 's of acceleration, which may exceed the data sheet absolute maximum limits. See the ADXL345 data sheet for more information.

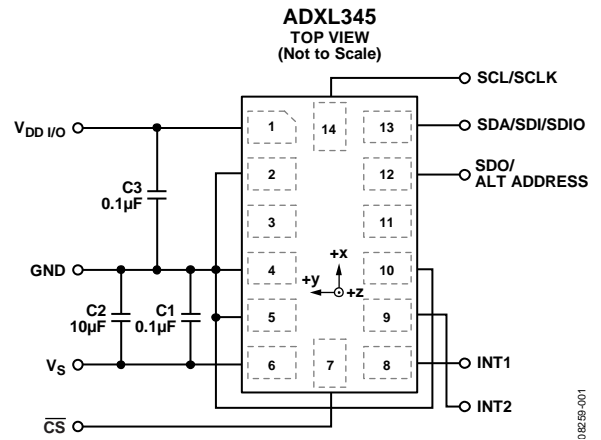

Figure 1. Schematic

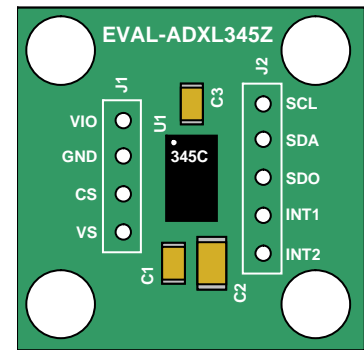

Figure 2. Physical Layout

#### Rev. 0

Evaluation boards are only intended for device evaluation and not for production purposes. Evaluation boards are supplied "as is" and without warranties of any kind, express, implied, or statutory including, but not limited to, any implied warranty of merchantability or fitness for a particular purpose. No license is granted by implication or otherwise under any patents or other intellectual property by application or use of evaluation boards. Information furnished by Analog Devices is believed to be accurate and reliable. However, no responsibility is assumed by Analog Devices for its use, nor for any infringements of patents or other rights of third parties that may result from its use. Analog Devices reserves the right to change devices or specifications at any time without notice. Trademarks and registered trademarks are the property of their respective owners. Evaluation boards are not authorized to be used in life support devices or systems.

# EVAL-ADXL345Z

## ORDERING GUIDE

Model	Package Description
EVAL-ADXL345Z <sup>1</sup>	Evaluation Board

<sup>1</sup> Z = RoHS Compliant Part.

## ESD CAUTION



**ESD (electrostatic discharge) sensitive device.** Charged devices and circuit boards can discharge without detection. Although this product features patented or proprietary protection circuitry, damage may occur on devices subjected to high energy ESD. Therefore, proper ESD precautions should be taken to avoid performance degradation or loss of functionality.