



MAX9937 Evaluation Kit

General Description

The MAX9937 evaluation kit (EV kit) is an assembled and tested PCB used to evaluate the MAX9937 automotive grade current-sense amplifier, designed for unidirectional high-side current-sense applications. The EV kit can be used to demonstrate the applicability of the MAX9937 to withstand automotive transients, such as load-dump protection, reverse-battery protection, and filtering for EMI.

Component List

DESIGNATION	QTY	DESCRIPTION
C1	1	1 μ F \pm 10%, 50V X7R ceramic capacitor (1206) Murata GRM31MR71H105KA TDK C3216X7R1H105K
C2, C4	0	Not installed, capacitors (0603)
C3	1	0.01 μ F \pm 10%, 50V X7R ceramic capacitor (0603) Murata GRM188R71H103K TDK C1608X7R1H103K
R1	1	0.05 Ω \pm 1%, 0.5W current-sense resistor (1206) IRC LRC-LR1206LF-01-R050-F
R2	1	20k Ω \pm 1% resistor (0603)
R3, R4	2	1k Ω \pm 1% resistor (1206)
U1	1	Automotive grade current-sense amplifier (5 SC70) Maxim MAX9937AXK+
—	1	PCB: MAX9937 Evaluation Kit+

Component Suppliers

SUPPLIER	PHONE	WEBSITE
IRC, Inc.	361-992-7900	www.irctt.com
Murata Electronics North America, Inc.	770-436-1300	www.murata-northamerica.com
TDK Corp.	847-803-6100	www.component.tdk.com

Note: Indicate that you are using the MAX9937 when contacting these component suppliers.

Features

- ◆ Reverse-Battery and Load-Dump Protection
-20V to +40V
- ◆ +4V to +28V Input Common-Mode Range
- ◆ +2.7V to +5.5V Supply Range
- ◆ Flexible EMI Filtering
- ◆ Lead(Pb)-Free and RoHS Compliant
- ◆ Fully Assembled and Tested

Ordering Information

PART	TYPE
MAX9937EVKIT+	EV Kit

+Denotes lead(Pb)-free and RoHS compliant.

Quick Start

Recommended Equipment

Before beginning, the following equipment is needed:

- 12V, 2A power supply (VBAT)
- 5V power supply (VCC)
- Electronic load capable of sinking 2A
- Digital voltmeter (DVM)

Procedure

The MAX9937 EV kit is fully assembled and tested. Follow the steps below to verify board operation.

Caution: Do not turn on power supplies until all connections are completed.

- 1) Set the input power supply to 12V and connect the positive terminal to the VBAT pad. Connect the ground of the power supply to the GND pad.
- 2) Set the VCC power supply to 5V and connect the positive terminal to the VCC pad. Connect the ground of the VCC supply to the GND pad.
- 3) Set the electronic load to sink 2A.
- 4) Connect the electronic load's positive terminal to the LOAD pad. Connect the load's ground to the GND pad.
- 5) Connect the DVM across the VOUT pad and the GND pad.
- 6) Turn on the 5V power supply.

Evaluates: MAX9937

MAX9937 Evaluation Kit

- 7) Turn on the 12V power supply.
- 8) Adjust the electronic load current (I_{LOAD}) between 0A and 2A and verify that V_{OUT} is proportional to V_{SENSE} according to the following equation:

$$V_{OUT} = V_{SENSE} \times \frac{R2}{R3}$$

where $V_{SENSE} = I_{LOAD} \times R1$.

__Detailed Description of Hardware

The MAX9937 EV kit evaluates the MAX9937 unidirectional high-side current-sense amplifier, which features a 4V to 28V input common-mode voltage range that is independent of supply voltage ($VCC = 2.7V$ to $5.5V$). The MAX9937 monitors the current through a current-sense resistor by converting the sense voltage to a voltage output (V_{OUT}). Gain is set by the ratio of an output resistor ($R2$) and an input resistor ($R3$). High-side current monitoring with the MAX9937 does not interfere with the ground path of the load, making it useful for a variety of automotive battery/ECU monitoring applications.

The MAX9937 EV kit produces an output voltage (V_{OUT}) given by the following equations:

$$V_{SENSE} = I_{LOAD} \times R_{SENSE}$$

$$V_{OUT} = V_{SENSE} \times \frac{R2}{R3}$$

where I_{LOAD} is the current load applied to the device and R_{SENSE} is the current-sense resistor $R1$ (e.g., $I_{LOAD} = 2A$, $R_{SENSE} = 0.05\Omega$, $R2 = 20k\Omega$, $R3 = 1k\Omega$, and $V_{OUT} = 2V$).

Overvoltage Protection

The MAX9937 EV kit provides a $1k\Omega$ resistor at each of the RSP and RSN inputs to demonstrate the reverse-battery and load-dump protection capabilities of the MAX9937 IC. The normal operating V_{RSP} and V_{RSN} range is 4V to 28V, but the robust input ESD structure allows the input common-mode voltages to exceed this range for short periods of time.

Short-duration overvoltages on the battery line (V_{BAT} to $LOAD$) are isolated from the RSP and RSN pins of the MAX9937 by the use of input resistors $R3$ and $R4$. The input ESD clamp structure is designed so the device can withstand short-duration ($< 1s$) overvoltages up to 40V when using resistors $R3$ and $R4$ of 500Ω or greater. The circuit can also withstand a reverse-battery voltage of $-20V$. During reverse-battery conditions, size $R3$ and $R4$ input resistors to withstand their expected power dissipations. Refer to the *Input Common-Mode Voltages > 28V and < 0V* section in the MAX9937 IC data sheet for a more detailed description.

EMI Filtering

The MAX9937 EV kit provides two uninstalled capacitor pads ($C2$ and $C4$), which the user can populate to improve performance in the presence of input common-mode voltage and input differential-voltage transients. Refer to the *Flexible EMI Filtering* section in the MAX9937 IC data sheet for a more detailed description.

MAX9937 Evaluation Kit

Evaluates: MAX9937

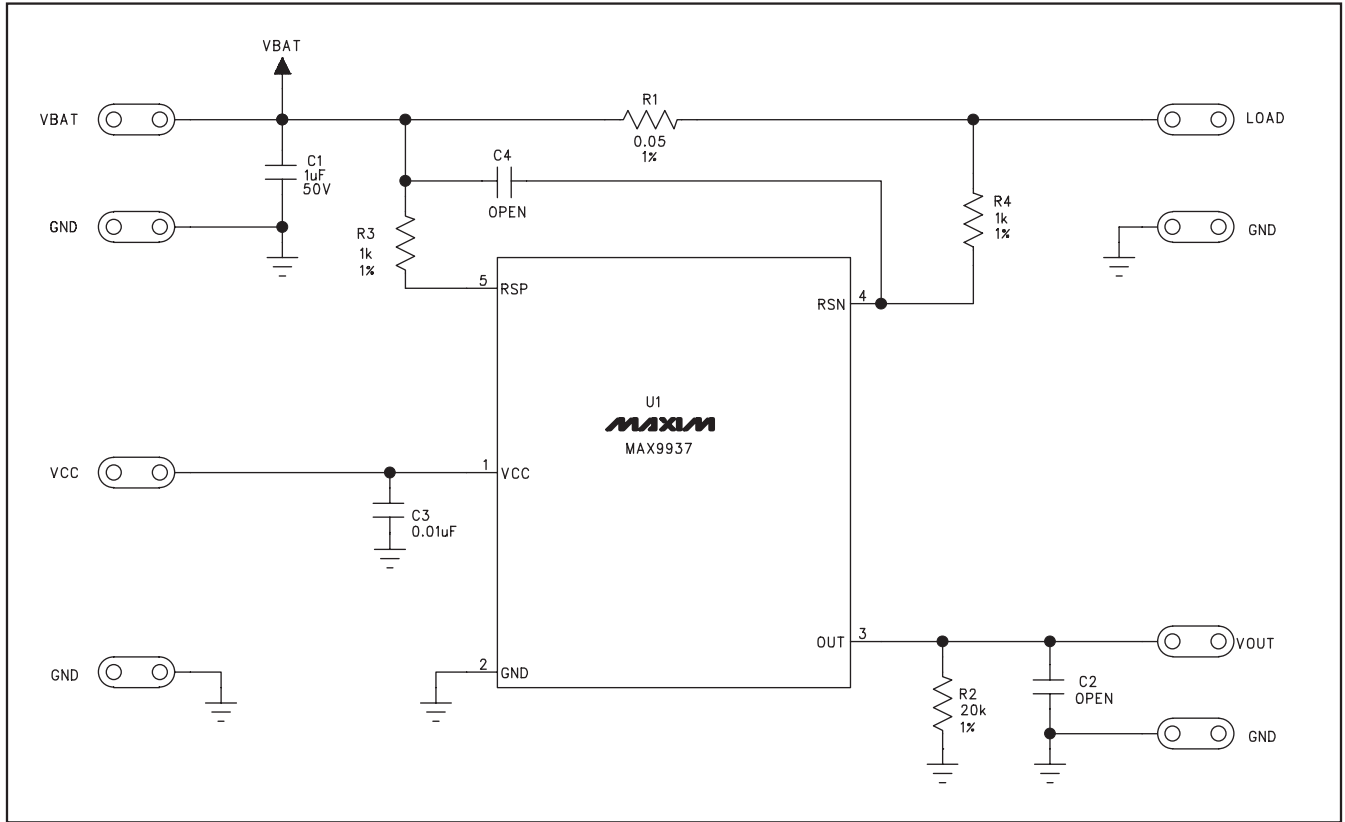

Figure 1. MAX9937 EV Kit Schematic

MAX9937 Evaluation Kit

Evaluates: MAX9937

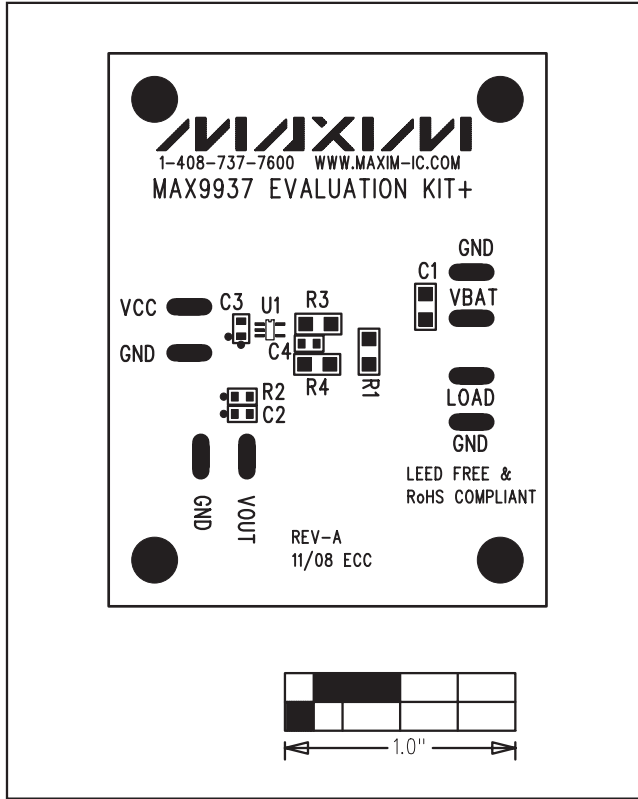

Figure 2. MAX9937 EV Kit Component Placement Guide—Component Side

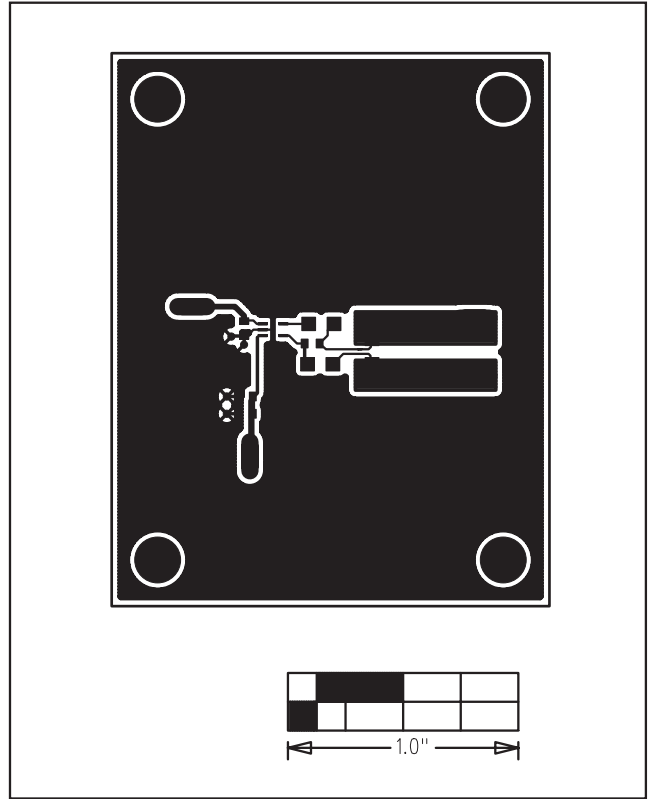

Figure 3. MAX9937 EV Kit Component PCB Layout—Component Side

MAX9937 Evaluation Kit

Evaluates: MAX9937

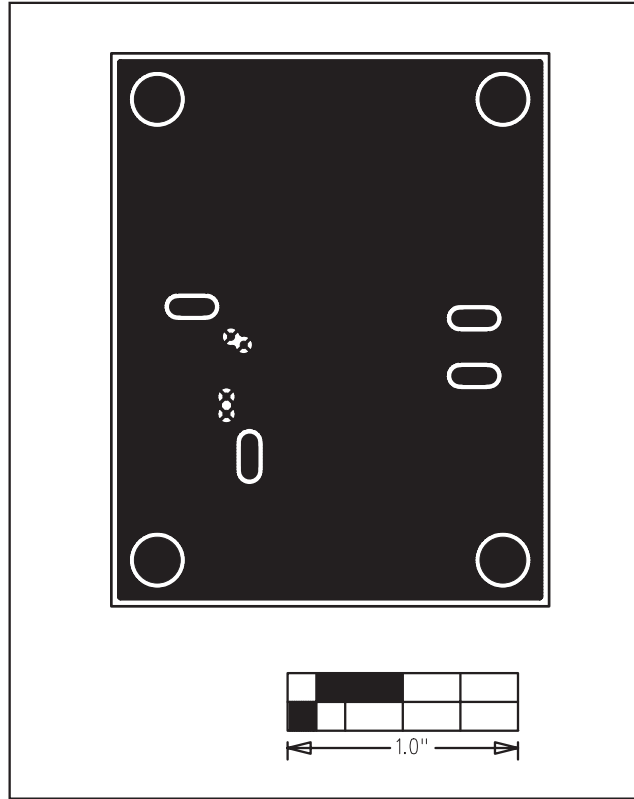

Figure 4. MAX9937 EV Kit PCB Layout—Solder Side

Maxim cannot assume responsibility for use of any circuitry other than circuitry entirely embodied in a Maxim product. No circuit patent licenses are implied. Maxim reserves the right to change the circuitry and specifications without notice at any time.

Maxim Integrated Products, 120 San Gabriel Drive, Sunnyvale, CA 94086 408-737-7600 _____ 5

© 2009 Maxim Integrated Products

MAXIM is a registered trademark of Maxim Integrated Products, Inc.