

LME49722

Low Noise, High Performance, High Fidelity Dual Audio Operational Amplifier

General Description

The LME49722 is part of the ultra-low distortion, low noise, high slew rate operational amplifier series optimized and fully specified for high performance, high fidelity applications. Combining advanced leading-edge process technology with state-of-the-art circuit design, the LME49722 audio operational amplifiers deliver superior audio signal amplification for outstanding audio performance. The LME49722 combines extremely low voltage noise density (1.9nV/ $\sqrt{\text{Hz}}$) rate with vanishingly low THD+N (0.00002%) to easily satisfy the most demanding audio applications. To ensure that the most challenging loads are driven without compromise, the LME49722 has a high slew rate of $\pm 22\text{V}/\mu\text{s}$ and an output current capability of $\pm 28\text{mA}$. Further, dynamic range is maximized by an output stage that drives $2\text{k}\Omega$ loads to within 1V of either power supply voltage.

The LME49722 has a wide supply range of $\pm 2.5\text{V}$ to $\pm 18\text{V}$. Over this supply range the LME49722 maintains excellent common-mode and power supply rejection, and low input bias current. This Audio Operational Amplifier achieves outstanding AC performance while driving complex loads with values as high as 100pF with gain value greater than 2. Directly interchangeable with LME49720, LM4562 and LME49860 for similar operating voltages.

Key Specifications

■ Wide Operating Voltage Range	$\pm 2.5\text{V}$ to $\pm 18\text{V}$
■ Equivalent Noise (Frequency = 1kHz)	1.9nV/ $\sqrt{\text{Hz}}$ (typ)
■ Equivalent Noise (Frequency = 10Hz)	2.8nV/ $\sqrt{\text{Hz}}$ (typ)

■ PSRR	120dB (typ)
■ Slew Rate	$\pm 22\text{V}/\mu\text{s}$ (typ)
■ THD+N ($A_V = 1$, $V_{\text{OUT}} = 3V_{\text{RMS}}$, $f_{\text{IN}} = 1\text{kHz}$)	
$R_L = 2\text{k}\Omega$	0.00002% (typ)
$R_L = 600\Omega$	0.00002% (typ)
■ Open Loop Gain ($R_L = 600\Omega$)	135dB (typ)
■ Input Bias Current	50nA (typ)
■ Voltage Offset	$\pm 0.02\text{mV}$ (typ)

Features

- Easily drives 600Ω loads
- Optimized for superior audio signal fidelity
- Output short circuit protection
- PSRR and CMRR exceed 120dB (typ)

Applications

- Ultra high quality audio amplification
- High fidelity preamplifiers, phono preamps, and multimedia
- High performance professional audio
- High fidelity equalization and crossover networks with active filters
- High performance line drivers and receivers
- Low noise industrial applications including test, measurement, and ultrasound

Typical Application

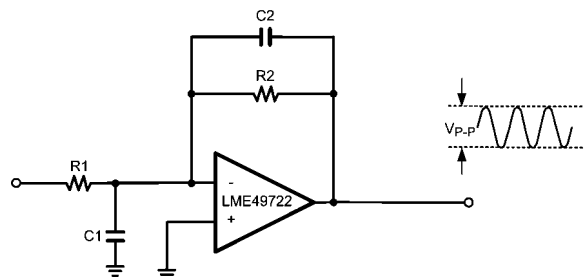

$f_{\text{MAX}} = > 300\text{ kHz}$ for $V_{\text{p-p}} = 20\text{V}$, $R_2 C_2 \approx R_1 C_1$

30057910

FIGURE 1. Wide Bandwidth Low Noise Low Drift Amplifier

Connection Diagram

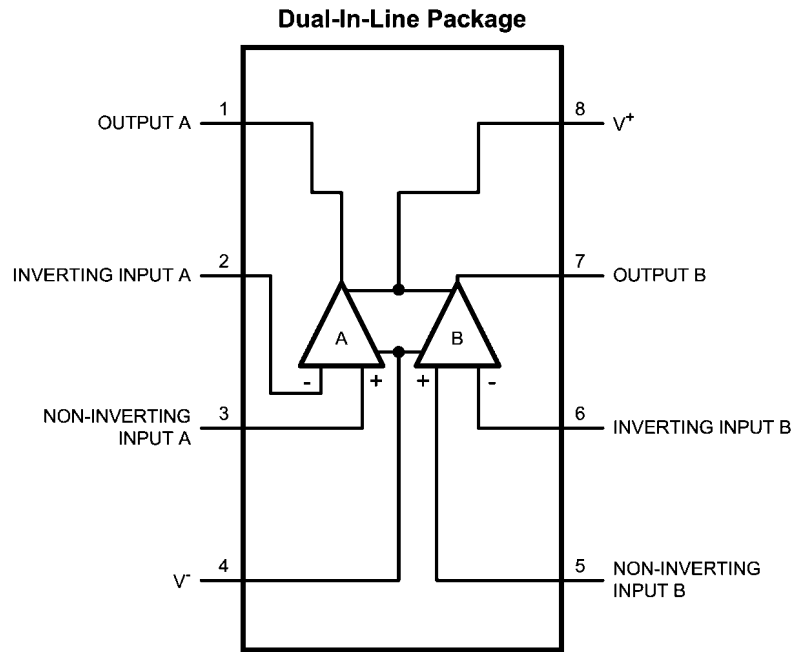

Order Number LME49722MA
See NS Package Number — M08A

30057955

Absolute Maximum Ratings (Notes 1, 2)

If Military/Aerospace specified devices are required, please contact the National Semiconductor Sales Office/ Distributors for availability and specifications.

Supply Voltage ($V_S = V_{CC} - V_{EE}$)	38V
Storage Temperature	-65°C to 150°C
Input Voltage	(V-) - 0.7V to (V+) + 0.7V
Output Short Circuit (Note 3)	Continuous
ESD Susceptibility (Note 4)	2000V
ESD Susceptibility (Note 5)	200V

Junction Temperature (T_{JMAX})	150°C
Thermal Resistance	
θ_{JA}	154°C/W
θ_{JC}	27°C/W

Operating Ratings

Temperature Range	
$T_{MIN} \leq T_A \leq T_{MAX}$	-40°C \leq T_A \leq 85°C
Supply Voltage Range	$\pm 2.5V \leq V_S \leq \pm 18V$

Electrical Characteristics for the LME49722 (Notes 1, 2) The following specifications apply for $V_S = \pm 15V$ and $\pm 18V$, $R_L = 2k\Omega$, $f_{IN} = 1kHz$ unless otherwise specified. Limits apply for $T_A = 25^\circ C$,

Symbol	Parameter	Conditions	LME49722		Units (Limits)
			Typical	Limit	
			(Note 6)	(Note 7)	
THD+N	Total Harmonic Distortion + Noise	$A_V = 1$, $V_{OUT} = 3V_{rms}$ $R_L = 2k\Omega$ $R_L = 600\Omega$	0.00002 0.00002	0.00009	% % (max)
IMD	Intermodulation Distortion	$A_V = 1$, $V_{OUT} = 3V_{RMS}$ Two-tone, 60Hz & 7kHz 4:1	0.00002		%
GBWP	Gain Bandwidth Product	$f_{IN} = 100kHz$	55	45	MHz (min)
SR	Slew Rate	$A_V = 1$, $V_{OUT} = 10V_{P-P}$	± 22	± 15	V/ μs (min)
FPBW	Full Power Bandwidth	$V_{OUT} = 1V_{P-P}$, -3dB referenced to output magnitude at $f = 1kHz$	12		MHz
t_s	Settling time	$A_V = -1$, 10V step, $C_L = 100pF$ 0.1% error range	1.2		μs
e_{INV}	Equivalent Input Voltage Noise	$f_{BW} = 20Hz$ to 20kHz	0.25	0.35	μV_{RMS} (max)
e_N	Equivalent Input Voltage Density	$f = 1kHz$ $V_S = \pm 15V$ $V_S = \pm 18V$	1.9 1.9	2.5	nV/\sqrt{Hz} nV/\sqrt{Hz} (max)
		$f = 10Hz$ $V_S = \pm 15V$ $V_S = \pm 18V$	2.8 3.2		nV/\sqrt{Hz} nV/\sqrt{Hz}
I_n	Current Noise Density	$f = 1kHz$ $f = 10Hz$	2.6 6		pA/\sqrt{Hz} pA/\sqrt{Hz}
V_{OS}	Offset Voltage	$V_{CM} = 0V$	± 0.02	± 0.7	mV (max)
PSRR	Power Supply Rejection Ratio	$\Delta V_S = 20V$ (Note 8)	120	110	dB (min)
ISO_{CH-CH}	Channel-to-Channel Isolation	$f_{IN} = 1kHz$	136		dB
		$f_{IN} = 20kHz$	135		dB
I_B	Input Bias Current	$V_{CM} = 0V$ $V_S = \pm 15V$ $V_S = \pm 18V$	50 53	200	nA nA (max)
$\Delta I_{OS}/\Delta Temp$	Input Bias Current Drift vs Temperature	-40°C \leq T_A \leq 85°C	0.1		nA/°C
I_{OS}	Input Offset Current	$V_{CM} = 0V$ $V_S = \pm 15V$ $V_S = \pm 18V$	25 32	100	nA nA (max)

Symbol	Parameter	Conditions	LME49722		Units (Limits)
			Typical	Limit	
			(Note 6)	(Note 7)	
V_{IN-CM}	Common-Mode Input Voltage Range	$V_S = \pm 15V$	+14.0 -13.9	$(V_{CC}) - 2.0$ $(V_{EE}) + 2.0$	V (min) V (min)
		$V_S = \pm 18V$	+17.0 -16.9	$(V_{CC}) - 2.0$ $(V_{EE}) + 2.0$	V (min) V (min)
CMRR	Common-Mode Rejection	$-10V \leq V_{CM} \leq 10V$	128	110	dB (min)
Z_{IN}	Differential Input Impedance		30		k Ω
Z_{CM}	Common Mode Input Impedance	$-10V \leq V_{CM} \leq 10V$	1000		M Ω
A_{VOL}	Open Loop Voltage Gain	$-12V \leq V_{OUT} \leq 12V, R_L = 600\Omega$	135	120	dB
		$-12V \leq V_{OUT} \leq 12V, R_L = 2k\Omega$	140		dB
		$-12V \leq V_{OUT} \leq 12V, R_L = 10k\Omega$	140		dB
V_{OM}	Output Voltage Swing	$V_S = \pm 15V$ $R_L = 600\Omega$ $R_L = 2k\Omega$ $R_L = 10k\Omega$	+13.7/-14 ± 14.0 ± 14.1		V_{PEAK} V_{PEAK} V_{PEAK}
		$V_S = \pm 18V$ $R_L = 600\Omega$ $R_L = 2k\Omega$ $R_L = 10k\Omega$	+16.6/-16.8 ± 17.0 ± 17.1	± 15.5	$V_{PEAK} (min)$ V_{PEAK} V_{PEAK}
I_{OUT}	Output Current	$R_L = 600\Omega$ $V_S = \pm 15V$ $V_S = \pm 18V$	± 23 $\pm 27.6/-28$	± 23	mA mA (min)
I_{OUT-CC}	Short Circuit Current	Sink to Source	+43 -40		mA mA
Z_{OUT}	Output Impedance	$f_{IN} = 10kHz$			
		Closed-Loop Open-Loop	0.01 13		Ω Ω
I_S	Total Quiescent Power Supply Current	$I_{OUT} = 0mA$ $V_S = \pm 15V$ $V_S = \pm 18V$	12.1 12.3	16	mA mA (max)

Note 1: "Absolute Maximum Ratings" indicate limits beyond which damage to the device may occur, including inoperability and degradation of device reliability and/or performance. Functional operation of the device and/or non-degradation at the *Absolute Maximum Ratings* or other conditions beyond those indicated in the *Recommended Operating Conditions* is not implied. The *Recommended Operating Conditions* indicate conditions at which the device is functional and the device should not be operated beyond such conditions. All voltages are measured with respect to the ground pin, unless otherwise specified.

Note 2: The *Electrical Characteristics* tables list guaranteed specifications under the listed *Recommended Operating Conditions* except as otherwise modified or specified by the *Electrical Characteristics Conditions* and/or Notes. Typical specifications are estimations only and are not guaranteed.

Note 3: The maximum power dissipation must be derated at elevated temperatures and is dictated by T_{JMAX} , θ_{JA} , and the ambient temperature, T_A . The maximum allowable power dissipation is $P_{DMAX} = (T_{JMAX} - T_A) / \theta_{JA}$ or the number given in *Absolute Maximum Ratings*, whichever is lower. For the LME49722, $T_{JMAX} = 150^\circ C$ and the typical θ_{JC} is $27^\circ C/W$.

Note 4: Human body model, applicable std. JESD22-A114C.

Note 5: Machine model, applicable std. JESD22-A115-A.

Note 6: Typical values represent most likely parametric norms at $T_A = +25^\circ C$, and at the *Recommended Operation Conditions* at the time of product characterization and are not guaranteed.

Note 7: Datasheet min/max specification limits are guaranteed by test or statistical analysis.

Note 8: PSRR is measured as follow: V_{OS} is measured at two supply voltages, $\pm 5V$ and $\pm 15V$. $PSRR = |20 \log(\Delta V_{OS} / \Delta V_S)|$.

Typical Performance Characteristics

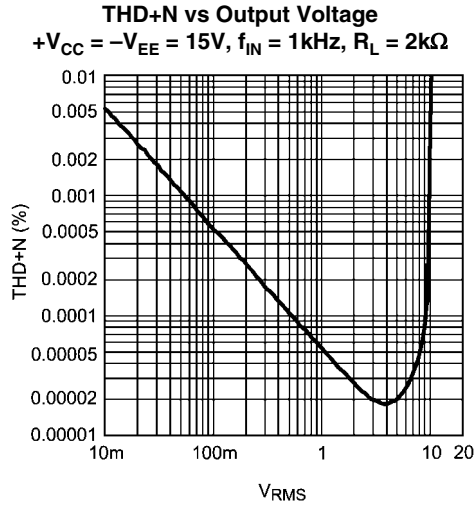

300579p5

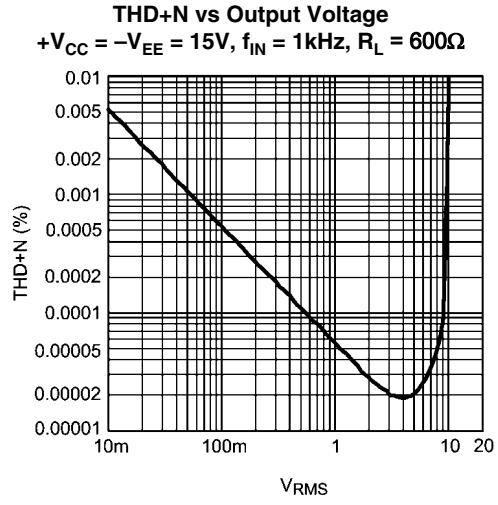

300579p6

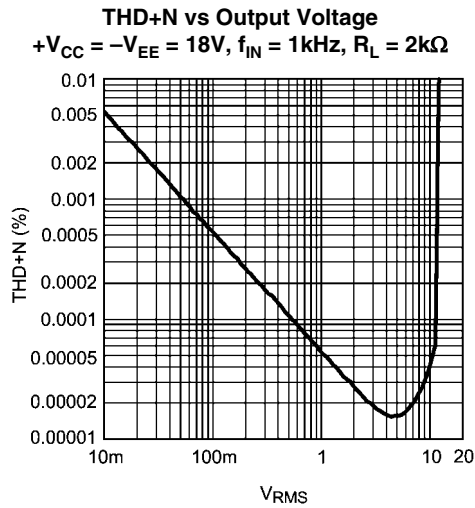

300579p7

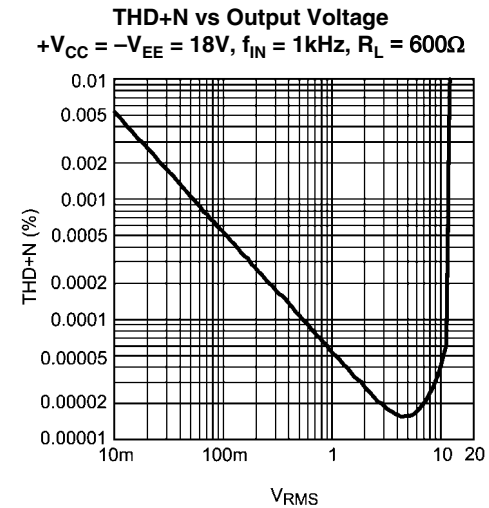

300579p8

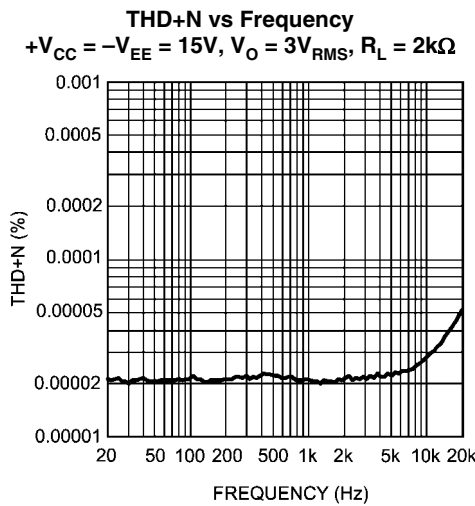

300579p1

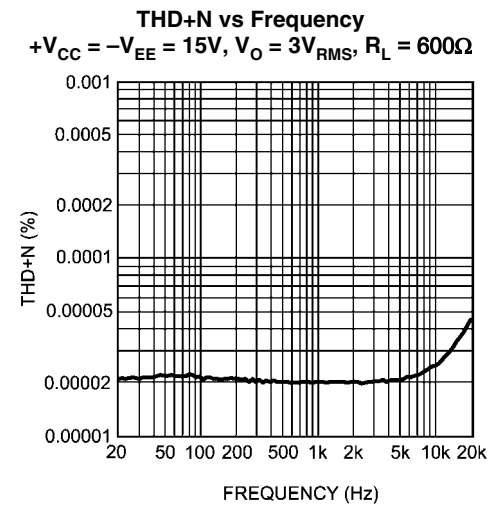

300579p2

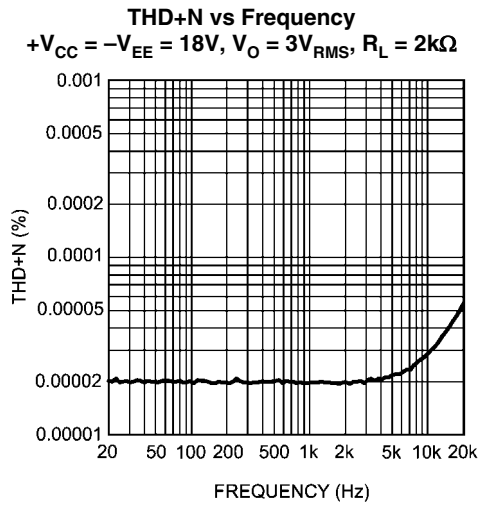

300579p3

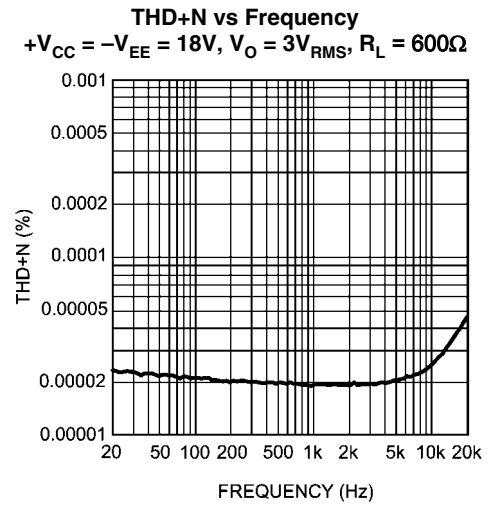

300579p4

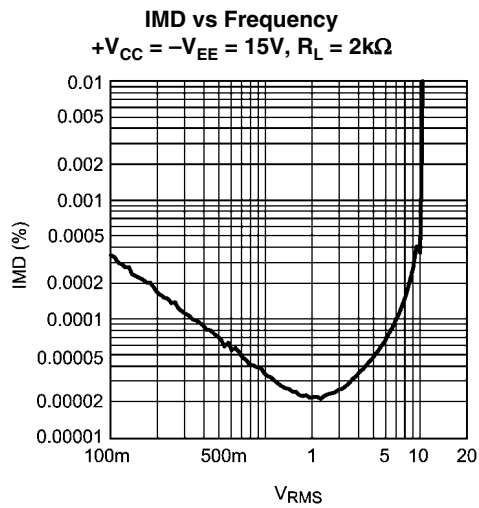

30057922

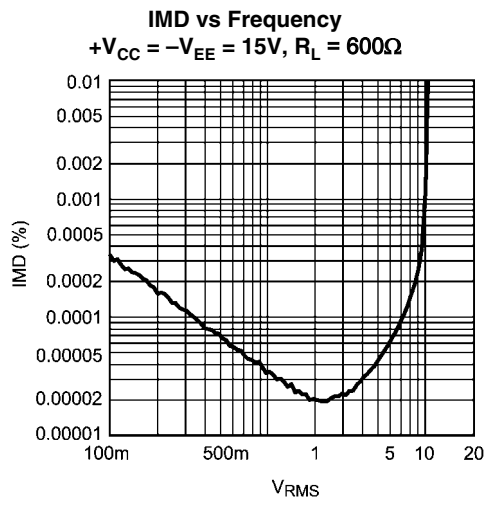

30057923

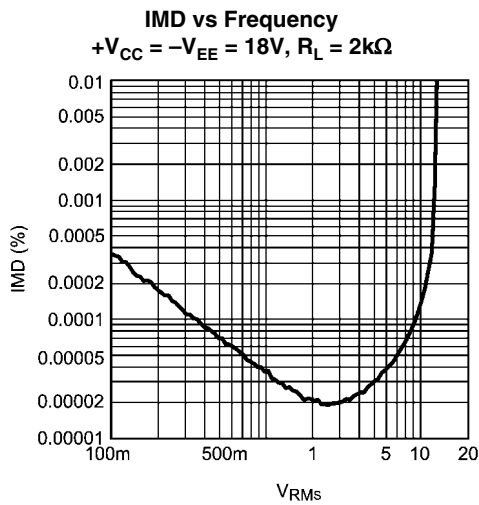

30057924

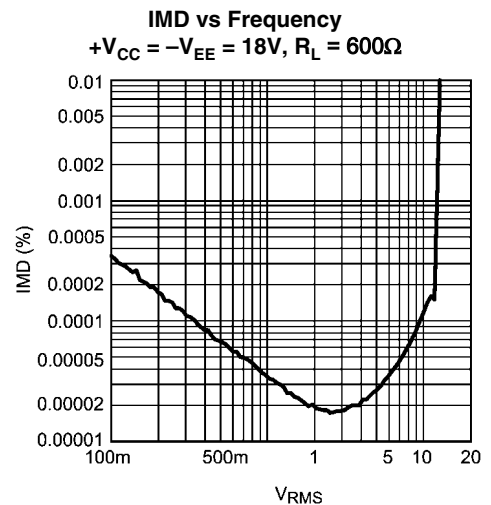

30057925

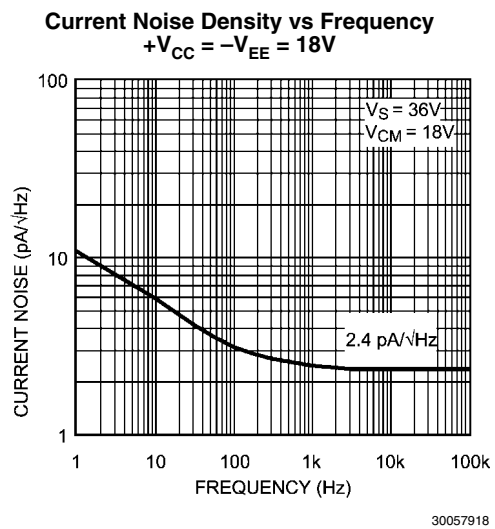
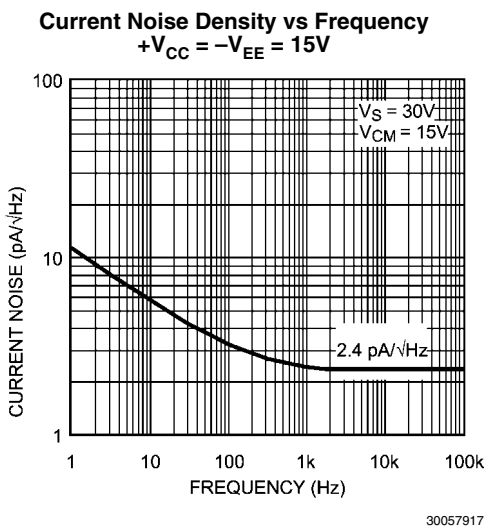
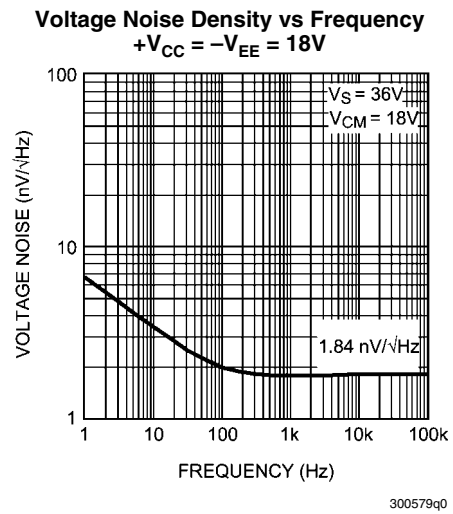
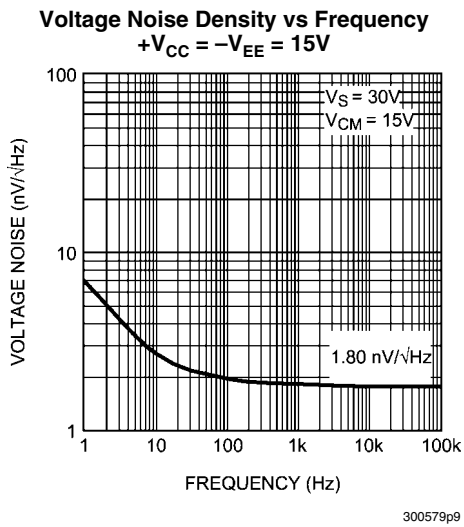
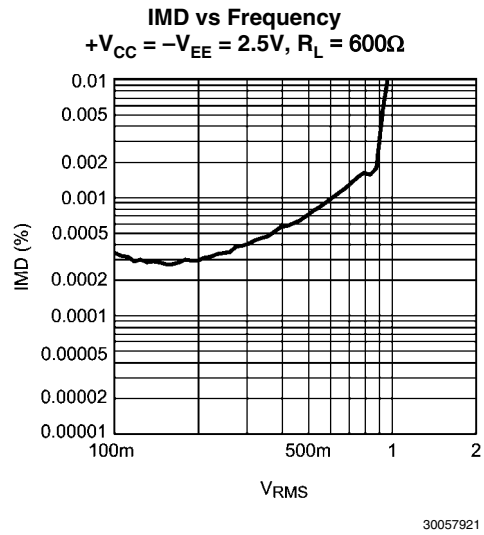
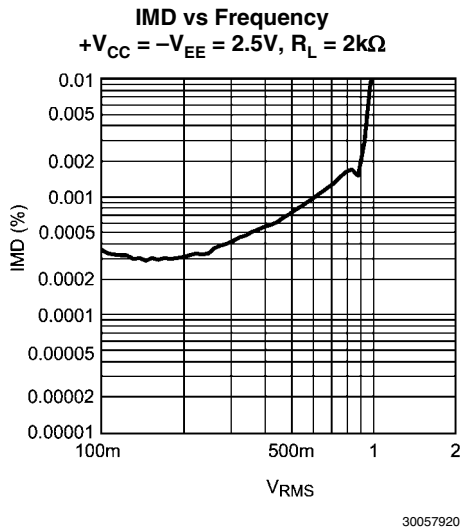

PSRR+ vs Frequency
 $+V_{CC} = -V_{EE} = 15V, V_{RIPPLE} = 200mV_{PP}, R_L = 2k\Omega$

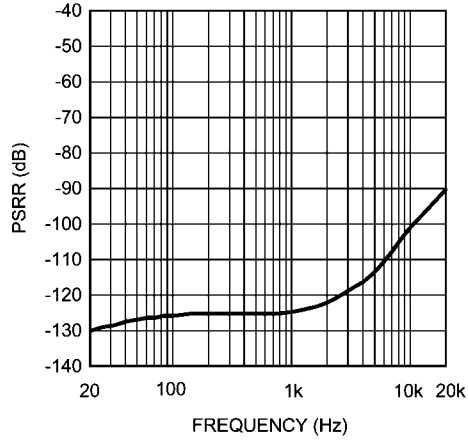

30057915

PSRR- vs Frequency
 $+V_{CC} = -V_{EE} = 15V, V_{RIPPLE} = 200mV_{PP}, R_L = 2k\Omega$

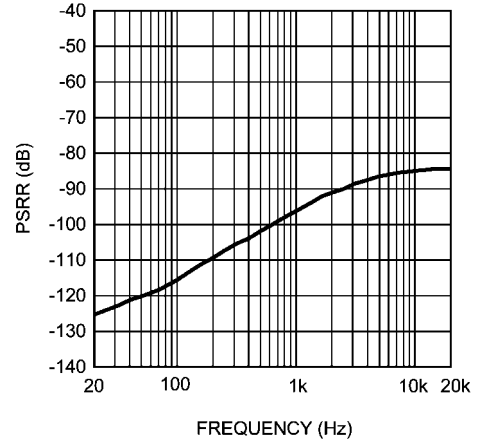

30057926

Crosstalk vs Frequency
 $+V_{CC} = -V_{EE} = 15V, R_L = 2k\Omega, V_{OUT} = 3V_{RMS}$

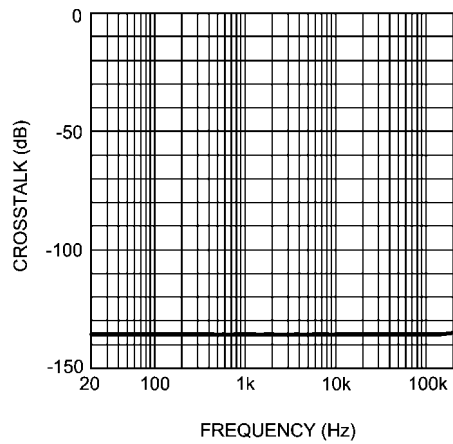

300579p0

CMRR vs Frequency
 $+V_{CC} = -V_{EE} = 15V, R_L = 2k\Omega$

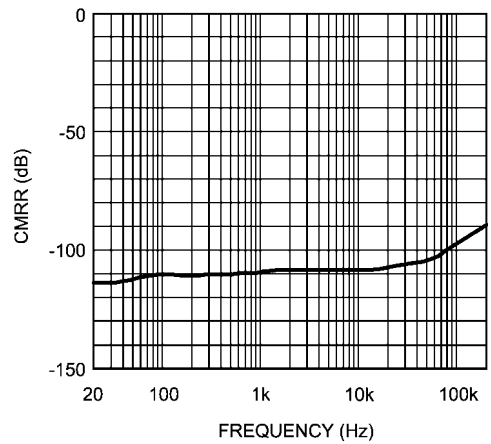

30057916

Output Voltage vs Supply Voltage
 THD+N = 1%, $R_L = 2k\Omega$

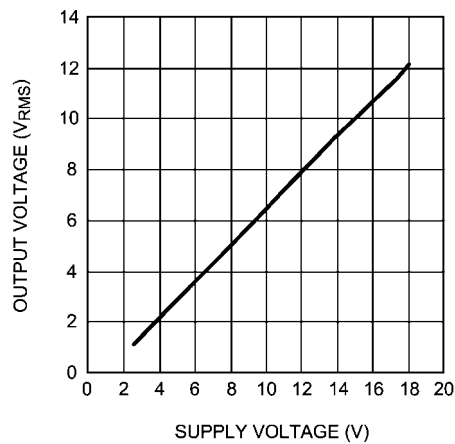

300579q1

Output Voltage vs Supply Voltage
 THD+N = 1%, $R_L = 600\Omega$

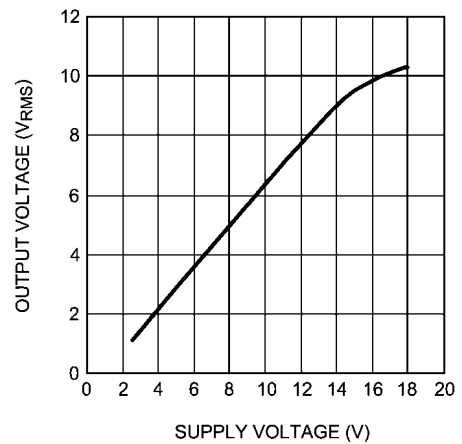

300579q2

Supply Current vs Supply Voltage
 $R_L = 2k\Omega$

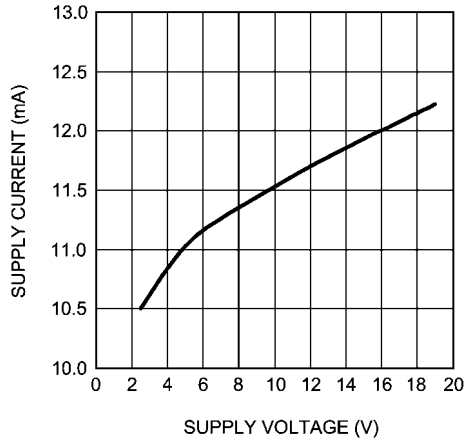

30057911

Full Power Bandwidth vs Frequency
 $+V_{CC} = -V_{EE} = 15V, R_L = 2k\Omega$

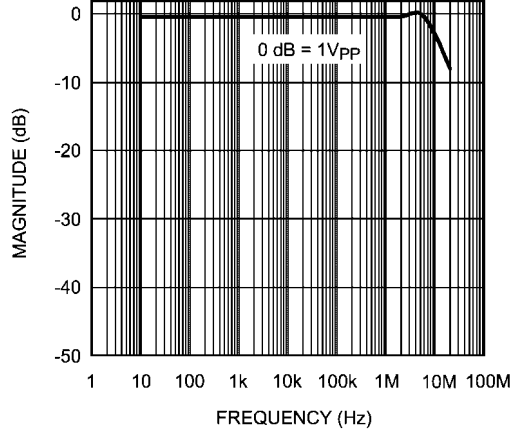

30057919

Gain Phase vs Frequency
 $+V_{CC} = -V_{EE} = 15V$

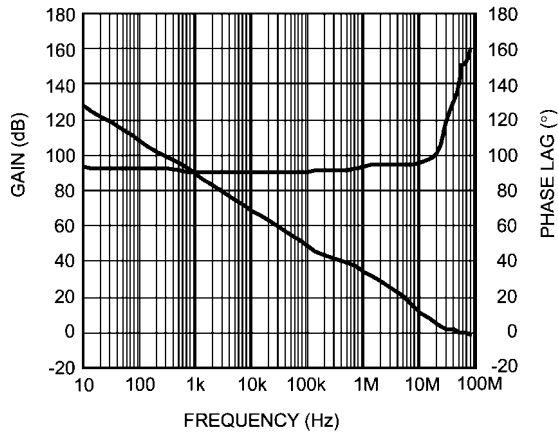

30057914

Application Information

APPLICATION HINTS

The LME49722 is a high speed operational amplifier which can operate stably in most of the applications. For the application with gain greater than 2, capacitive loads up to 100pF will cause little change in the phase characteristics of the am-

plifiers and are therefore allowable. Capacitive loads greater than 10pF must be isolated from the output, if the gain value is less than 2. The most straightforward way to do this is to put a resistor (its value $\geq 20\Omega$) in series with the output. The resistor will also prevent unnecessary power dissipation if the output is accidentally shorted.

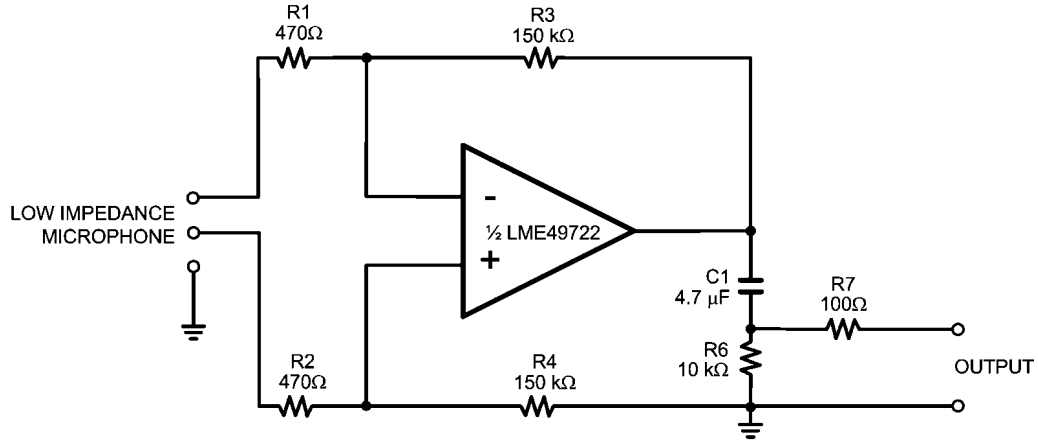

- Total voltage noise density: $e_{N_total}^2 \approx e_N^2 + e_{N_R1}^2 + e_{N_R2}^2 = 1.9^2 + 2(2.7^2)$,
then $e_{N_total} = 4.3 \text{ nV}/\sqrt{\text{Hz}}$. For $e_{N_R1} = e_{N_R2} \approx 2.7 \text{ nV}/\sqrt{\text{Hz}}$, if $R1 = R2 \approx 470\Omega$.
- Or total voltage noise = $0.13 \mu\text{V}$ input referred in a 1 kHz noise bandwidth.

30057913

FIGURE 2. Low Impedance Microphone Pre-amplifier

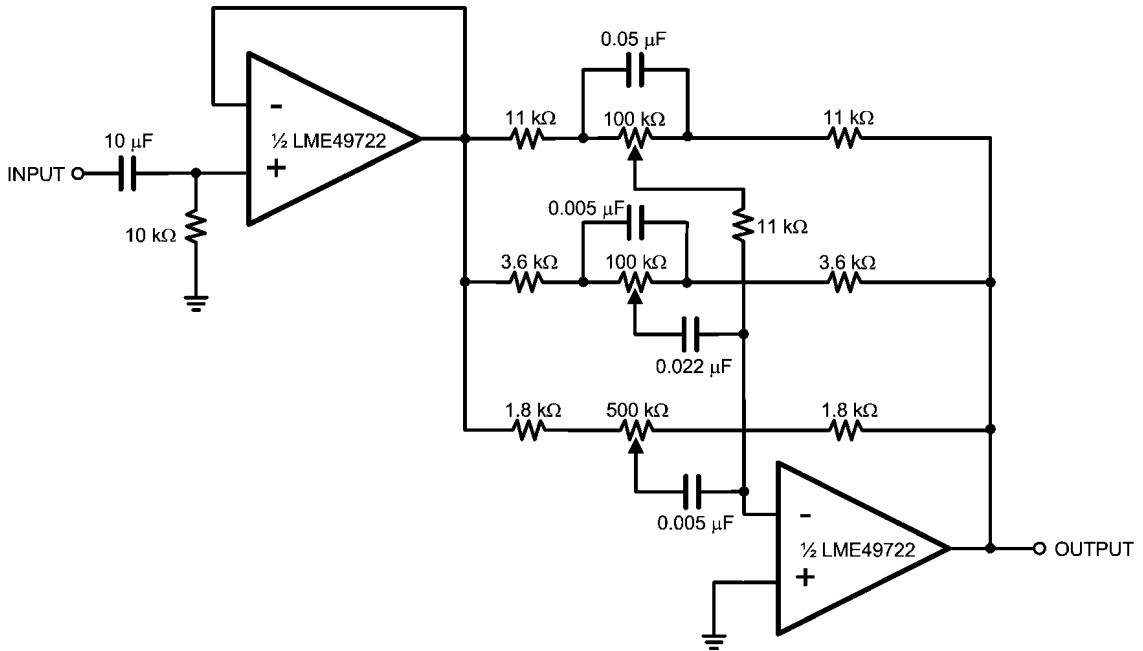

30057912

FIGURE 3. Three-Band Active Tone Control

Revision History

Rev	Date	Description
1.0	03/27/08	Initial release.

Physical Dimensions inches (millimeters) unless otherwise noted

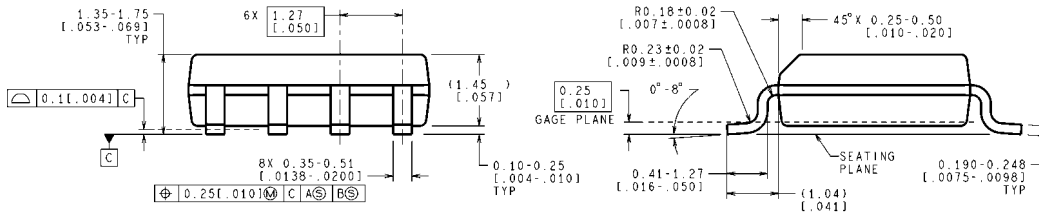
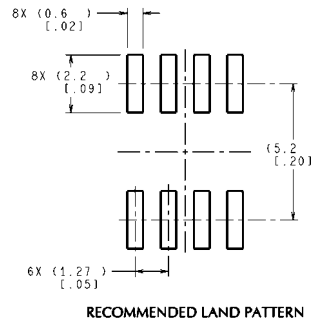
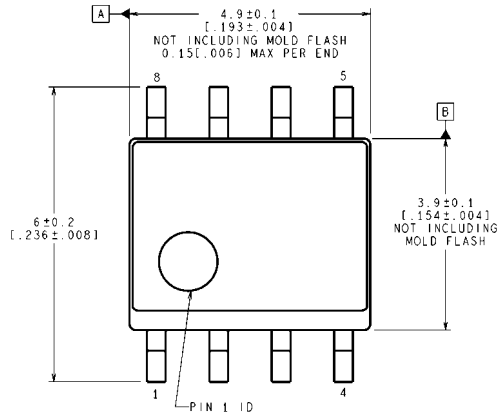

CONTROLLING DIMENSION IS MILLIMETER
VALUES IN [] ARE INCHES
DIMENSIONS IN () FOR REFERENCE ONLY

M08A (Rev L)

Narrow SOIC Package
Order Number LME49722MA
NS Package Number M08A

Notes

LME49722

Notes

For more National Semiconductor product information and proven design tools, visit the following Web sites at:

Products		Design Support	
Amplifiers	www.national.com/amplifiers	WEBENCH	www.national.com/webench
Audio	www.national.com/audio	Analog University	www.national.com/AU
Clock Conditioners	www.national.com/timing	App Notes	www.national.com/appnotes
Data Converters	www.national.com/adc	Distributors	www.national.com/contacts
Displays	www.national.com/displays	Green Compliance	www.national.com/quality/green
Ethernet	www.national.com/ethernet	Packaging	www.national.com/packaging
Interface	www.national.com/interface	Quality and Reliability	www.national.com/quality
LVDS	www.national.com/lvds	Reference Designs	www.national.com/refdesigns
Power Management	www.national.com/power	Feedback	www.national.com/feedback
Switching Regulators	www.national.com/switchers		
LDOs	www.national.com/ldo		
LED Lighting	www.national.com/led		
PowerWise	www.national.com/powerwise		
Serial Digital Interface (SDI)	www.national.com/sdi		
Temperature Sensors	www.national.com/tempsensors		
Wireless (PLL/VCO)	www.national.com/wireless		

THE CONTENTS OF THIS DOCUMENT ARE PROVIDED IN CONNECTION WITH NATIONAL SEMICONDUCTOR CORPORATION ("NATIONAL") PRODUCTS. NATIONAL MAKES NO REPRESENTATIONS OR WARRANTIES WITH RESPECT TO THE ACCURACY OR COMPLETENESS OF THE CONTENTS OF THIS PUBLICATION AND RESERVES THE RIGHT TO MAKE CHANGES TO SPECIFICATIONS AND PRODUCT DESCRIPTIONS AT ANY TIME WITHOUT NOTICE. NO LICENSE, WHETHER EXPRESS, IMPLIED, ARISING BY ESTOPPEL OR OTHERWISE, TO ANY INTELLECTUAL PROPERTY RIGHTS IS GRANTED BY THIS DOCUMENT.

TESTING AND OTHER QUALITY CONTROLS ARE USED TO THE EXTENT NATIONAL DEEMS NECESSARY TO SUPPORT NATIONAL'S PRODUCT WARRANTY. EXCEPT WHERE MANDATED BY GOVERNMENT REQUIREMENTS, TESTING OF ALL PARAMETERS OF EACH PRODUCT IS NOT NECESSARILY PERFORMED. NATIONAL ASSUMES NO LIABILITY FOR APPLICATIONS ASSISTANCE OR BUYER PRODUCT DESIGN. BUYERS ARE RESPONSIBLE FOR THEIR PRODUCTS AND APPLICATIONS USING NATIONAL COMPONENTS. PRIOR TO USING OR DISTRIBUTING ANY PRODUCTS THAT INCLUDE NATIONAL COMPONENTS, BUYERS SHOULD PROVIDE ADEQUATE DESIGN, TESTING AND OPERATING SAFEGUARDS.

EXCEPT AS PROVIDED IN NATIONAL'S TERMS AND CONDITIONS OF SALE FOR SUCH PRODUCTS, NATIONAL ASSUMES NO LIABILITY WHATSOEVER, AND NATIONAL DISCLAIMS ANY EXPRESS OR IMPLIED WARRANTY RELATING TO THE SALE AND/OR USE OF NATIONAL PRODUCTS INCLUDING LIABILITY OR WARRANTIES RELATING TO FITNESS FOR A PARTICULAR PURPOSE, MERCHANTABILITY, OR INFRINGEMENT OF ANY PATENT, COPYRIGHT OR OTHER INTELLECTUAL PROPERTY RIGHT.

LIFE SUPPORT POLICY

NATIONAL'S PRODUCTS ARE NOT AUTHORIZED FOR USE AS CRITICAL COMPONENTS IN LIFE SUPPORT DEVICES OR SYSTEMS WITHOUT THE EXPRESS PRIOR WRITTEN APPROVAL OF THE CHIEF EXECUTIVE OFFICER AND GENERAL COUNSEL OF NATIONAL SEMICONDUCTOR CORPORATION. As used herein:

Life support devices or systems are devices which (a) are intended for surgical implant into the body, or (b) support or sustain life and whose failure to perform when properly used in accordance with instructions for use provided in the labeling can be reasonably expected to result in a significant injury to the user. A critical component is any component in a life support device or system whose failure to perform can be reasonably expected to cause the failure of the life support device or system or to affect its safety or effectiveness.

National Semiconductor and the National Semiconductor logo are registered trademarks of National Semiconductor Corporation. All other brand or product names may be trademarks or registered trademarks of their respective holders.

Copyright© 2008 National Semiconductor Corporation

For the most current product information visit us at www.national.com



**National Semiconductor
Americas Technical
Support Center**
Email:
new.feedback@nsc.com
Tel: 1-800-272-9959

**National Semiconductor Europe
Technical Support Center**
Email: europe.support@nsc.com
German Tel: +49 (0) 180 5010 771
English Tel: +44 (0) 870 850 4288

**National Semiconductor Asia
Pacific Technical Support Center**
Email: ap.support@nsc.com

**National Semiconductor Japan
Technical Support Center**
Email: jpn.feedback@nsc.com