

LMH6552SDEVAL High Speed Differential Amplifier Evaluation Board

National Semiconductor
Application Note 1743
Vannavong Philavanh
June 20, 2008



General Description

The LMH6552SDEVAL evaluation board is designed to aid in the characterization of National Semiconductor's LMH6552 fully differential amplifier in an 8-pin LLP package. The LMH6552 is part of the LMH® high speed amplifier family.

Use the evaluation board as a guide for high frequency layout and as a tool to aid in device testing and characterization.

The evaluation board schematic is shown below in *Figure 1*. Refer to the product datasheets for recommended component values.

Basic Operation

The LMH6552SDEVAL evaluation board has been set up to provide maximum flexibility for evaluating National's differential LMH6552 operational amplifier. The board supports fully differential operation as well as single-ended to differential and single-ended to single-ended operation. For fully differential operation, use resistors R_5 and R_6 to set the input impedance of the amplifier. Input resistance will be equal to $2 \cdot R_5 \parallel 2 \cdot R_1$. Where $R_5 = R_6$ and $R_1 = R_2$. In this mode resistors R_1 , R_2 , R_3 and R_4 set the gain of the amplifier. Amplifier gain = $R_F/R_G = R_4/R_2$ where $R_1 = R_2$ and $R_3 = R_4$. For single-ended input mode of operation, the input and termination resistance must be properly configured to give the correct gain and R_{IN} . For example, in the case of the LMH6552, if a gain of 2 V/V is desired, $R_5 = 28.7\Omega$, $R_1 = R_2 = 127\Omega$, $R_3 = R_4 = 275\Omega$, and $R_6 = 68.1\Omega$. Which will make $R_{IN} = 50\Omega$ at the most positive node of R_5 looking into R_2 . Further details of single-ended input mode calculations for the LMH6552 can be found in the datasheet. Components R_7 , R_8 , C_6 , and C_7 should be used for AC-couple applications otherwise can be left empty.

For differential output applications, load R_{12} and R_{13} with the desired values to match the output load and leave R_{10} and R_{11} empty.

If single-ended output is desired leave R_{12} and R_{13} empty and load R_{10} , R_{11} and an output transformer such as the ADT4-1WT from Mini Circuits. The ADT4-1WT has a 4:1 impedance ratio (2:1 turns/voltage ratio). This is particularly useful for interfacing to 50Ω test equipment. When referencing the transformer datasheet, the 980600016 evaluation board has the primary windings on the output side of the evaluation board and the amplifier is driving the secondary windings. This provides a step down transformation from the differential amplifier output to the test equipment. The center-tapped secondary winding also allows a differential to single

ended conversion (Balun). The impedance seen by the differential amplifier = $(R_{10} + R_{11} + R_L \cdot 4)$, where R_L is the impedance from pin 3 of the transformer to the load.

Pin 7 on the LMH6552 device is the enable (EN) pin that can be used to disable the device with an external signal. Refer to LMH6552 datasheet for more details.

Layout Considerations

Printed circuit board layout and supply bypassing play major roles in determining high frequency performance. When designing your own board use these evaluation boards as a guide and follow these steps to optimize high frequency performance:

1. Symmetry is of the utmost importance.
2. Use precision resistors 0.1% or 0.01%.
3. Use a ground plane.
4. Include large ($\sim 10 \mu\text{F}$) capacitors on both supplies (C_1 and C_3).
5. Near the device use $0.01 \mu\text{F}$ ceramic capacitors from both supplies to ground (C_2 , C_4).
6. A capacitor between V^+ and V^- (C_5) is optional, but will help lower distortion.
7. Remove the ground and power planes from under and around the part, especially the input and output pins.
8. Minimize all trace lengths.
9. Use terminated transmission lines for long traces.

Sample artwork for the LMH6552SDEVAL™ Evaluation board is included on the next page in *Figure 2*.

Measurement Hints

Balance, CMRR and HD2 are highly dependent on resistor matching. Use 0.1 or 0.01% resistors.

The LMH6552SDEVAL evaluation board is designed for differential or single-ended output measurements, but not both at the same time. When not using the transformer make sure to leave R_{10} and R_{11} empty. Likewise, when making single-ended output measurements leave R_{12} and R_{13} empty.

Many differential amplifiers are optimized for the higher impedances represented by most ADCs.

On a differential amplifier both inputs are inverting, keep parasitic capacitance to a minimum on both inputs. Also, using probes of any kind on a differential circuit is not recommended.

T1 = Mini Circuits ADT4-1WT

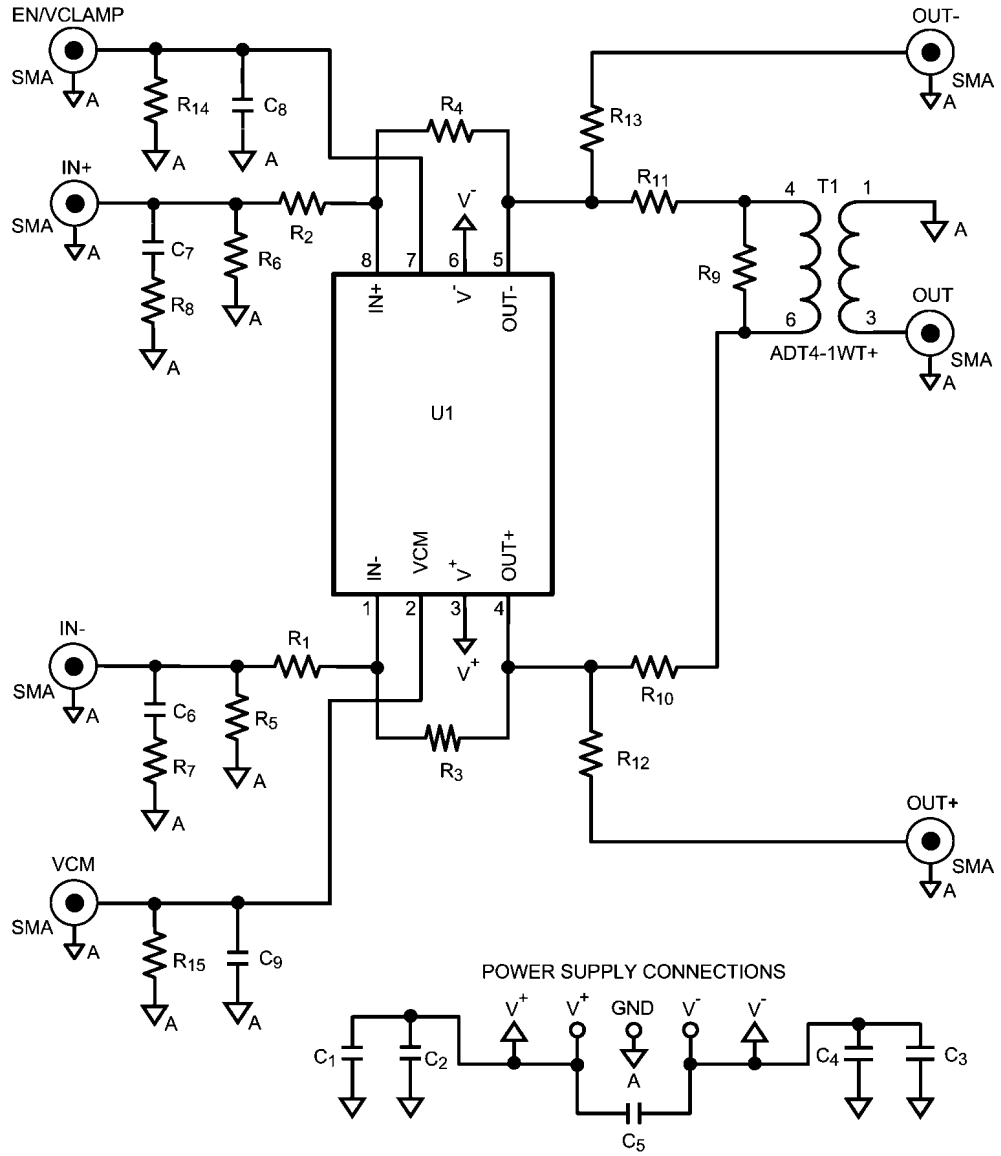

30033403

FIGURE 1. Board Schematic

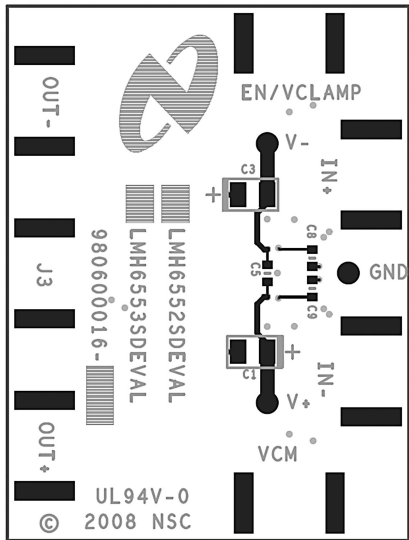

30033402

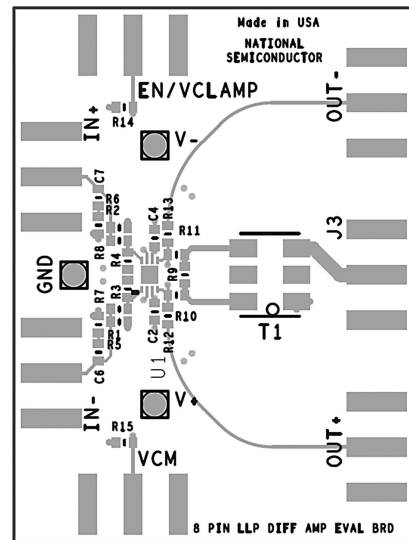

30033401

FIGURE 2. Board Layout

Notes

For more National Semiconductor product information and proven design tools, visit the following Web sites at:

Products		Design Support	
Amplifiers	www.national.com/amplifiers	WEBENCH	www.national.com/webench
Audio	www.national.com/audio	Analog University	www.national.com/AU
Clock Conditioners	www.national.com/timing	App Notes	www.national.com/appnotes
Data Converters	www.national.com/adc	Distributors	www.national.com/contacts
Displays	www.national.com/displays	Green Compliance	www.national.com/quality/green
Ethernet	www.national.com/ethernet	Packaging	www.national.com/packaging
Interface	www.national.com/interface	Quality and Reliability	www.national.com/quality
LVDS	www.national.com/lvds	Reference Designs	www.national.com/refdesigns
Power Management	www.national.com/power	Feedback	www.national.com/feedback
Switching Regulators	www.national.com/switchers		
LDOs	www.national.com/lido		
LED Lighting	www.national.com/led		
PowerWise	www.national.com/powerwise		
Serial Digital Interface (SDI)	www.national.com/sdi		
Temperature Sensors	www.national.com/tempsensors		
Wireless (PLL/VCO)	www.national.com/wireless		

THE CONTENTS OF THIS DOCUMENT ARE PROVIDED IN CONNECTION WITH NATIONAL SEMICONDUCTOR CORPORATION ("NATIONAL") PRODUCTS. NATIONAL MAKES NO REPRESENTATIONS OR WARRANTIES WITH RESPECT TO THE ACCURACY OR COMPLETENESS OF THE CONTENTS OF THIS PUBLICATION AND RESERVES THE RIGHT TO MAKE CHANGES TO SPECIFICATIONS AND PRODUCT DESCRIPTIONS AT ANY TIME WITHOUT NOTICE. NO LICENSE, WHETHER EXPRESS, IMPLIED, ARISING BY ESTOPPEL OR OTHERWISE, TO ANY INTELLECTUAL PROPERTY RIGHTS IS GRANTED BY THIS DOCUMENT.

TESTING AND OTHER QUALITY CONTROLS ARE USED TO THE EXTENT NATIONAL DEEMS NECESSARY TO SUPPORT NATIONAL'S PRODUCT WARRANTY. EXCEPT WHERE MANDATED BY GOVERNMENT REQUIREMENTS, TESTING OF ALL PARAMETERS OF EACH PRODUCT IS NOT NECESSARILY PERFORMED. NATIONAL ASSUMES NO LIABILITY FOR APPLICATIONS ASSISTANCE OR BUYER PRODUCT DESIGN. BUYERS ARE RESPONSIBLE FOR THEIR PRODUCTS AND APPLICATIONS USING NATIONAL COMPONENTS. PRIOR TO USING OR DISTRIBUTING ANY PRODUCTS THAT INCLUDE NATIONAL COMPONENTS, BUYERS SHOULD PROVIDE ADEQUATE DESIGN, TESTING AND OPERATING SAFEGUARDS.

EXCEPT AS PROVIDED IN NATIONAL'S TERMS AND CONDITIONS OF SALE FOR SUCH PRODUCTS, NATIONAL ASSUMES NO LIABILITY WHATSOEVER, AND NATIONAL DISCLAIMS ANY EXPRESS OR IMPLIED WARRANTY RELATING TO THE SALE AND/OR USE OF NATIONAL PRODUCTS INCLUDING LIABILITY OR WARRANTIES RELATING TO FITNESS FOR A PARTICULAR PURPOSE, MERCHANTABILITY, OR INFRINGEMENT OF ANY PATENT, COPYRIGHT OR OTHER INTELLECTUAL PROPERTY RIGHT.

LIFE SUPPORT POLICY

NATIONAL'S PRODUCTS ARE NOT AUTHORIZED FOR USE AS CRITICAL COMPONENTS IN LIFE SUPPORT DEVICES OR SYSTEMS WITHOUT THE EXPRESS PRIOR WRITTEN APPROVAL OF THE CHIEF EXECUTIVE OFFICER AND GENERAL COUNSEL OF NATIONAL SEMICONDUCTOR CORPORATION. As used herein:

Life support devices or systems are devices which (a) are intended for surgical implant into the body, or (b) support or sustain life and whose failure to perform when properly used in accordance with instructions for use provided in the labeling can be reasonably expected to result in a significant injury to the user. A critical component is any component in a life support device or system whose failure to perform can be reasonably expected to cause the failure of the life support device or system or to affect its safety or effectiveness.

National Semiconductor and the National Semiconductor logo are registered trademarks of National Semiconductor Corporation. All other brand or product names may be trademarks or registered trademarks of their respective holders.

Copyright© 2008 National Semiconductor Corporation

For the most current product information visit us at www.national.com



National Semiconductor Americas Technical Support Center
Email: support@nsc.com
Tel: 1-800-272-9959

National Semiconductor Europe Technical Support Center
Email: europe.support@nsc.com
German Tel: +49 (0) 180 5010 771
English Tel: +44 (0) 870 850 4288

National Semiconductor Asia Pacific Technical Support Center
Email: ap.support@nsc.com

National Semiconductor Japan Technical Support Center
Email: jpn.feedback@nsc.com