

Introduction

The ISL2827xINEVAL1Z evaluation board is a design platform containing all the circuitry needed to characterize critical performance parameters of the ISL28270, ISL28271, ISL28272 or ISL28273 Dual Instrumentation Amplifiers using a variety of user defined test circuits.

The ISL2827x series of amplifiers are dual channel instrumentation amplifiers optimized for 2.4V to 5V single supplies. These devices feature an Input Range Enhancement Circuit (IREC) which enables the inputs to swing to the rails. The ISL28270 and ISL28273 maintain CMRR performance from the positive rail down to within 50mV of the negative rail. The ISL28271 and ISL28272 can swing 100mV beyond the rails. The output operation of all devices is rail-to-rail. The ISL28270 and ISL28272 are compensated for a minimum gain of 100 and the ISL28271 and ISL28273 are compensated for a minimum gain of 10.

Reference Documents

- ISL28270, ISL28273 Data Sheet, FN6260
- ISL28271, ISL28272 Data Sheet, FN6390

Evaluation Board Key Features

The ISL2827xINEVAL1Z is designed to be operated from a single supply (+2.4VDC to +5VDC), or from split supplies (± 1.2 VDC to ± 2.5 V). The board is configured for 2 independent instrumentation amplifiers connected for a closed loop gain of 101 (ISL28270, ISL28272) or a gain of 10 (ISL28271, ISL28273) with inverting and non-inverting high impedance terminated with 100k resistors to ground. Each amplifier contains it's own VREF input to establish an input common mode reference. An ENABLE select switch is provided for each amplifier to be used to save power by powering the device down.

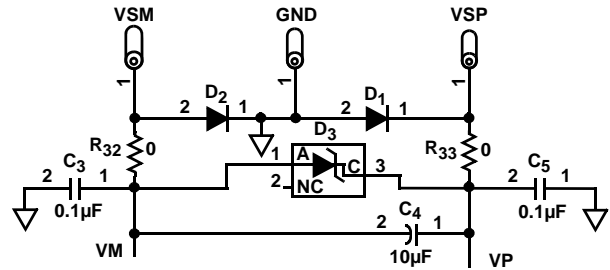

FIGURE 1. POWER SUPPLY CIRCUIT

Power Supplies (Refer to Figure 1)

External power connections are made through the VSP (+V), VSM (-V) and GND connections on the evaluation board. For single supply operation, the VSM (-V) and GND pins are tied together to the power supply negative terminal. For split supplies, VSP (+V) and VSM (-V) terminals connect to their respective power supply terminals. Resistors R32 and R33 are 0Ω but can be changed by the user to provide power supply filtering, or to reduce the voltage rate-of-rise to less than ± 1 V/ μ s. Anti-reverse diodes D1 and D2 protect the circuit in the case of accidental polarity reversal.

Amplifier Configuration (Refer to Figure 2)

The schematic of each of the two op amps with the components supplied is shown in Figure 2. The circuit implements a differential input instrumentation amp with a closed loop gain of 101 for the ISL28270 and ISL28272, and 10 for the ISL28271, ISL28273. The circuit can operate from a single 2.4VDC to +5VDC supply, or from dual supplies from ± 1.2 VDC to ± 2.5 VDC. The output common mode reference is applied to the VREF pin, and has a range from ground (VM) to VP.

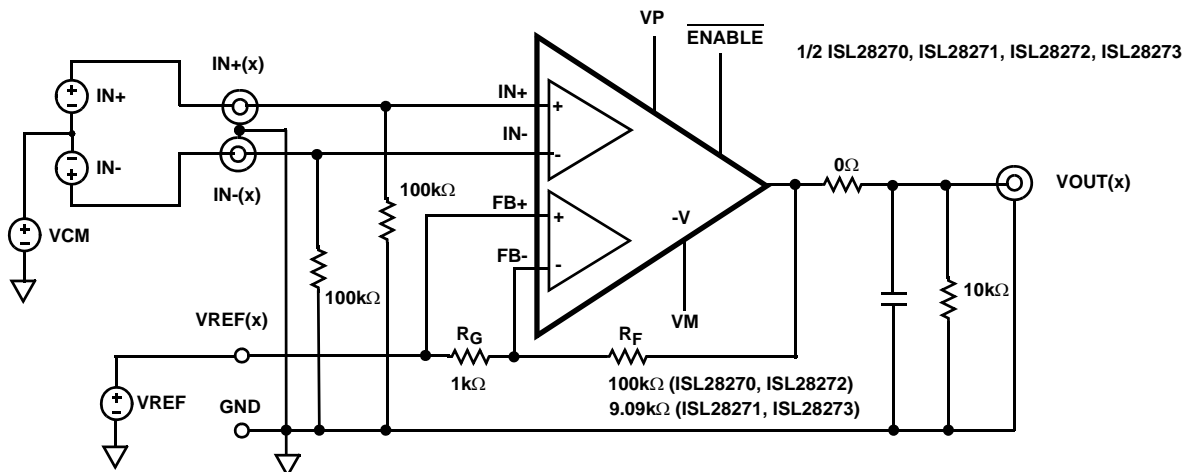

FIGURE 2. BASIC AMPLIFIER CONFIGURATION

User-selectable Options (Refer to Figure 3)

Component pads are included to enable a variety of user selectable circuits to be added to the amplifier differential inputs, the VREF input, and the amplifier feedback loop. A voltage divider and filter option can be added to establish a power supply tracking common mode reference at the VREF input, or a coaxial connection to the amplifier FB+ pin can be made at the FB+ BNC connector. The differential inputs have additional resistor placements for adding input attenuation, or to establish input DC offsets through the VREF pin.

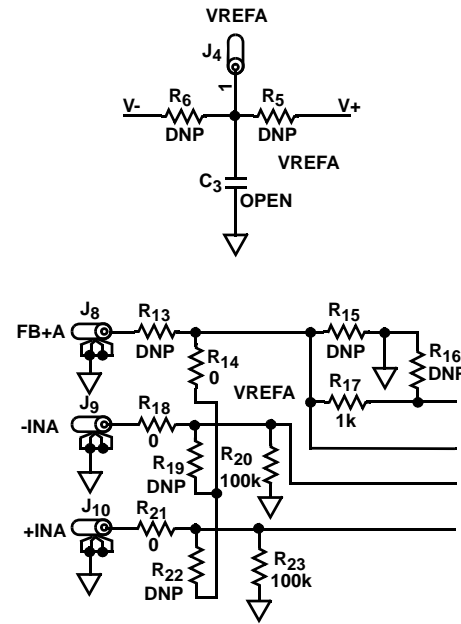
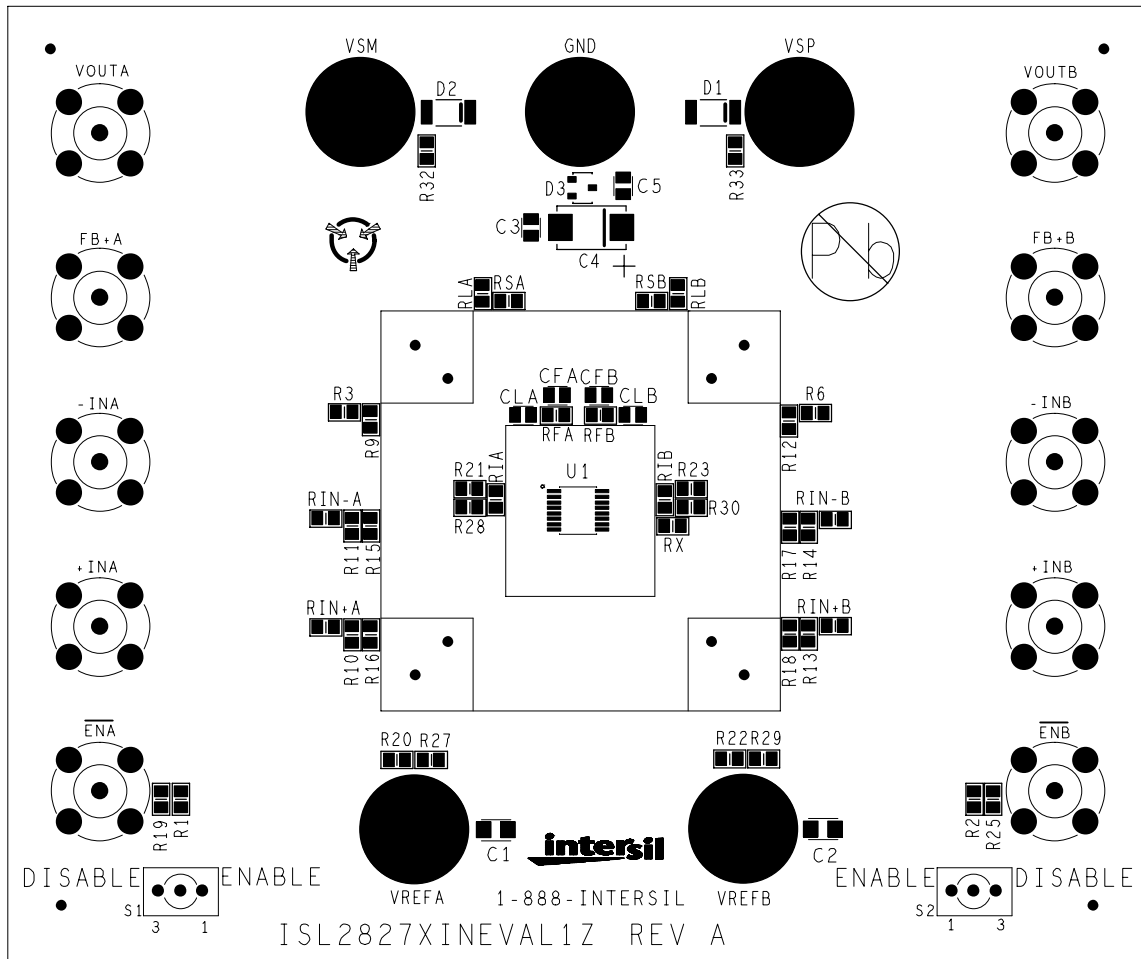

FIGURE 3. COMPONENT-SELECTABLE OPTIONS

ISL2827xINEVAL1Z Components Parts List

DEVICE #	DESCRIPTION	COMMENTS
C ₃ , C ₅	CAP, SMD, 0805, 0.1µF, 25V, 10%, X7R, ROHS	Power Supply Decoupling
C _{FA} , C _{FB} , C _{LA} , C _{LB}	CAP, SMD, 0805, DNP-PLACE HOLDER, ROHS	Optional Amplifier Feedback Caps Not Populated
C ₁ , C ₂	CAP, SMD, 1206, 1µF, 25V, 10%, X7R, ROHS	Power Supply Decoupling
C ₄	CAP-TANTALUM, SMD, D, 10µF, 35V, 10%, LOW ESR, ROHS	Optional VREF Filter Not Populated
D ₁ , D ₂	DIODE-RECTIFIER, SMD, MELF, 2 Ld, 50V, 1A, GPP, ROHS	Reverse Power Protection
U ₁	ISL28270FAZ or ISL28271FAZ or ISL28272FAZ or ISL28273FAZ INSTRUMENTATION AMP, 16P, QSOP, ROHS	
R ₃₂ , R ₃₃ , R _{IN+A} , R _{IN+B} , R _{IN-A} , R _{IN-B} , R _{SA} , R _{SB}	RES, SMD, 0805, 0Ω, 1/8W, TF, ROHS	0Ω User Selectable Resistors
R _{IA} , R _{IB}	RES, SMD, 0805, 1k, 1/8W, 1%, TF, ROHS	R _I Gain Resistors
R ₁ , R ₂	RES, SMD, 0805, 10k, 1/8W, 1%, TF, ROHS	ENABLE Pull-up Resistors
R ₁₅ to R ₁₈	RES, SMD, 0805, 100k, 1/10W, 1%, TF, ROHS	
R ₉ , R ₁₂ , R ₂₀ , R ₂₂ , R ₂₇ , R ₂₉	CAP, SMD, 0805, DNP-PLACE HOLDER, ROHS	User Selectable Resistors Not Populated
R _{FA} , R _{FB} (ISL28271, ISL28273)	RES, SMD, 0805, 9.09k, 1/8W, 1%, TF, ROHS	R _F Gain Resistors - ISL28271, ISL28272
R _{FA} , R _{FB} (ISL28270, ISL28272)	RES, SMD, 0805, 100k, 1/8W, 1%, TF, ROHS	R _F Gain Resistors - ISL28270
R ₃ , R ₆ , R ₁₀ , R ₁₁ , R ₁₃ , R ₁₄ , R ₁₉ , R ₂₁ , R ₂₃ , R ₂₅ , R ₂₈ , R ₃₀ , R _{LA} , R _{LB} , R _X	RES, SMD, 0805, DNP-PLACE HOLDER, ROHS	User Selectable Resistors Not Populated
S ₁ , S ₂	SWITCH-SEALED MINI TOGGLE, TH, 3P, SP, ON/NONE/ON, GOLD	Enable/Disable Select Switches

ISL2827xINEVAL1Z Top View



Intersil Corporation reserves the right to make changes in circuit design, software and/or specifications at any time without notice. Accordingly, the reader is cautioned to verify that the Application Note or Technical Brief is current before proceeding.

For information regarding Intersil Corporation and its products, see www.intersil.com

ISL2827xINEVAL1Z Schematic Diagram

